

bradscholars

Effect of Ultrasound on Molecular Structure Development of Polylactide

Item Type	Article
Authors	Bao, W.;Wu, H.;Guo, S.;Paradkar, Anant R;Kelly, Adrian L.;Brown, Elaine;Coates, Philip
Citation	Bao W, Wu H, Guo S et al (2014) Effect of Ultrasound on Molecular Structure Development of Polylactide. Polymer-Plastics Technology and Engineering. 53(9): 927-934.
DOI	https://doi.org/10.1080/03602559.2014.886062
Rights	© 2014 Taylor and Francis. Full-text reproduced in accordance with the publisher's self-archiving policy. This is an Author's Original Manuscript of an article published by Taylor & Francis in Polymer-Plastics Technology and Engineering on 20 May 2014. It is available online at http://dx.doi.org/10.1080/03602559.2014.886062 .
Download date	2026-04-19 17:35:21
Link to Item	https://bradscholars.brad.ac.uk/handle/10454/8027.2



The University of Bradford Institutional Repository

<http://bradscholars.brad.ac.uk>

This work is made available online in accordance with publisher policies. Please refer to the repository record for this item and our Policy Document available from the repository home page for further information.

To see the final version of this work please visit the publisher's website. Access to the published online version may require a subscription.

Link to publisher's version: <http://dx.doi.org/10.1080/03602559.2014.886062>

Citation: Bao W, Wu H, Guo S et al (2014) Effect of Ultrasound on Molecular Structure Development of Polylactide. *Polymer-Plastics Technology and Engineering*. 53(9)

Copyright statement: © 2014 Taylor and Francis. Full-text reproduced in accordance with the publisher's self-archiving policy.

This is an Author's Original Manuscript of an article published by Taylor & Francis in *Polymer-Plastics Technology and Engineering* on 20 May 2014. It is available online at <http://dx.doi.org/10.1080/03602559.2014.886062>.

Effect of Ultrasound on Molecular Structure Development of

Poly lactide

Wenting Bao¹, Hong Wu^{1*}, Shaoyun Guo^{1*}, Anant Paradkar², Adrian Kelly³, Elaine Brown³,
Phil Coates³

¹*The State Key Laboratory of Polymer Materials Engineering, Polymer Research Institute of
Sichuan University, Chengdu 610065, China*

²*Centre for Pharmaceutical Engineering Science, University of Bradford, Bradford BD71DP, UK*

³*Advanced Materials RKT Centre, Polymer IRC, University of Bradford, Bradford BD71DP, UK*

ABSTRACT:

In this work, effect of ultrasound on molecular structure development of Polylactide (PLA) was studied. It was found that the intrinsic viscosity of PLA decreased with increasing treating time, temperature and ultrasound time. Different from traditional thermal degradation of PLA, the degradation of PLA under ultrasound treatment showed that chain scission and chain combination of PLA competed with each other in the degradation process, which could be divided into two steps. The mechanism of ultrasound degradation of PLA was proposed. Furthermore, Thermal properties were characterized by DSC to show heat and ultrasound effects on molecular structure development of PLA.

Keywords: Polylactide, molecular structure, Ultrasound, degradation, combination.

Introduction

As one of biodegradable and bioresorbable polymers, Polylactide (PLA) has attracted the interest of various research groups in last 20 years [1-9]. Since it could degrade after application into products that were eliminated from the body by excretion or respiration, PLA was widely applied by many researchers in the field of controlled

* To whom correspondence should be addresses. (Prof. Wu, Email: wh@scu.edu.cn, Fax: 86-28-85466077)

* To whom correspondence should be addresses. (Prof. Guo, Email: sguo@scu.edu.cn, Fax: 86-28-85405135)

release [10-14]. However, the lack of hydrophilic groups in PLA and the slowly in-vivo degradation rate of PLA limited its application as drug carrier. Therefore, the increase of the hydrophilicity and degradation rate of PLA was necessary. Currently, there were several methods for the modification of PLA, such as copolymerization, compounding, blending and surface modification. The problems, such as how to prepare copolymers with suitable grafting ratio, how to improve compatibility and interfacial strength of the blends, how to improve the dispersibility of the dispersed phase in the matrix, should be resolved.

From the perspective of the preparation of PLA-based controlled release system, the traditional method with solvent processes showed various problems such as the environmental pollution and the residual organic solvent [15]. Hot melt extrusion (HME), which had many advantages in the preparation of PLA-based controlled release system [16], was introduced into the field of pharmaceutical preparation. And it was important and necessary to control the dispersion of the drug particles in the polymer matrix and comprehend molecular structure development of the polymer matrix during HME.

It was found in our previous research [17-24] that ultrasound assisted melt processing had both physical and chemical effects on the polymer and its blends and composites. With the physical effect of ultrasound, the dispersion of the small particles in polymer matrix could be improved [24-25]. In addition, with the chemical effect of ultrasound, the polymers, such as PS, EPDM and PA6, would be degraded. The ultrasound degradation of polymer melt became serious with the increase of degradation time and

the decrease of temperature. Meanwhile, the molecular scission of polymer would lead to reactive radicals, thus the compatibility of blends was improved [17, 26-28].

Meanwhile, ultrasound was used in the field of pharmaceuticals [29-31].

Since there were two factors affecting the release behavior of drug from polymeric matrix: One was the dispersion and the dissolution property of drug [32-34]; the other was the degradation property of the polymer matrix in release process [35-37], ultrasound assisted HME should be one potential method to prepare PLA-based controlled release system. Due to the degradation of PLA matrix could obviously affect the release behavior of drugs, it was necessary for us to investigate the molecular development of PLA matrix under ultrasound.

Until now there was no literature reported about the degradation of PLA melt treated by ultrasound. The researches focused on the thermal degradation of PLA. The molecular chains of PLA were easy to breakdown under hydrolytic conditions or during thermal treatment [38-39], due to the repeated aliphatic ester structure in PLA. It was found that the degradation of PLA was caused by several kinds of reactions, such as thermal oxidative degradation [40], hydrolytic degradation [41] or by chain cleavage induced by ultrasound in the solution [42]. And the thermal degradation of PLA was affected by the structure of PLA (such as the molecular weight and its distribution, heterogeneous monomer ratio, the content of water and residual monomer, the content of the catalyst, etc.) and the processing conditions (such as the processing temperature, time, pressure, etc.). Based on our previous research about the ultrasound degradation of polymer melts, it could be surmised that

ultrasound could induce the degradation of PLA and the degradation of PLA melt under ultrasound would be affected by the ultrasound treatment and the thermal treatment.

In this paper, ultrasound was introduced into PLA melt. The effects of treating temperature, treating time and ultrasound power on the molecular structure development of PLA were discussed. A mechanism of the molecular structure development of PLA under ultrasound was also proposed.

Experimental

Materials and Equipment

PLA used in the experiment was provided by Zhejiang Hisun Biomaterials Co., Ltd. . PLA (REVODE101) was a thermoplastic resin derived from annually renewable resources and it was specifically designed for extrusion applications. The melt flow index and density of PLA was 10 g/10min and $1.25\pm 0.05 \text{ g/cm}^3$, respectively.

A special ultrasound-assisted treater was developed in our laboratory, as described in Fig. 1. The degradation temperature and the ultrasound power could be controlled well. Diameter of the probes was 15 mm, maximum power output of ultrasound generator was 250 W, and frequency was 20 kHz.

Sample Preparation

A certain amount of PLA granules were filled into the cavity shown in Fig. 1, and kept at different temperature (170°C, 180°C and 190°C, respectively) for 5min, then the ultrasound irradiation with the power of 150W were induced to PLA melts for a certain time, then the treated PLA melts were cooled down to room temperature. The

degraded PLA samples were picked out from the cavity to measure the intrinsic viscosity and other characters.

Measurements

The intrinsic viscosity $[\eta]$ could be used to evaluate the degradation of PLA melts by semi-quantitative analysis. The intrinsic viscosity $[\eta]$ was measured at 30°C by Ubbelohde viscometer. The solvent was tetrahydrofuran (THF). Three samples were used to represent data.

Infrared spectra in the attenuated total reflection mode (FTIR-ATR) were obtained by Nicolet-IS10 Fourier-transform infra-red spectrometer (Thermo Electron Co., USA).

The PLA samples were analyzed in $650\text{-}4000\text{cm}^{-1}$ with a 4 cm^{-1} resolution.

The molecular weight and molecular weight distribution were measured by HLC-8320GPC instrument (TOSOH CORPORATION). The solvent was THF, the standard sample was polystyrene, the temperature of column was 40°C and the flow rate was 0.6 ml/min.

A TA-Q20 (USA) DSC was used to study the thermal properties (such as melting temperature (T_m) and cold crystallization temperature (T_{cc})) of PLA. A sample of about 7 mg was first heated from -10°C to 180°C at 10°C /min and hold for 3 minutes to erase the thermal history, and then it was cooled at the same speed to -10°C. Finally, the sample was scanned again to 180°C at 10°C /min. The crystallinity of PLA was calculated from

$$X_c = (\Delta H_m - \Delta H_{cc}) / 93.1$$

where the constant 93.1 J/g was the melting enthalpy (ΔH_m) for 100% crystalline

PLLA or PDLA homopolymers [43] and ΔH_{cc} was the enthalpy of the cold crystallization of PLA.

Results and Discussion

Intrinsic viscosity

The intrinsic viscosity was proportional to the molecular weight of PLA, thus the molecular weight and the degradation degree of PLA could be judged by the value of the intrinsic viscosity. PLA samples were treated at different temperature for several minutes. Fig. 2 showed the dependence of $[\eta]$ on the treating temperature and time. It could be clearly seen that $[\eta]$ of PLA decreased with the increase of the treating time at one fixed temperature. The decrease of intrinsic viscosity indicated the reduction of viscosity-average weight of PLA. The results showed that PLA degraded under only heat treatment, which was called as thermal degradation. From the three curves for different heating temperature, it could be found that when the heating time was fixed, the higher the heating temperature, the lower the intrinsic viscosity, and when the heating temperature was fixed, the longer the heating time of PLA sample, the lower the intrinsic viscosity. It was consistent with that reported in the literature [32]. Therefore, it could be considered that in our experiment the thermal degradation of PLA was mainly controlled by the melt temperature and the treating time. Increasing the processing temperature and extending the processing time would result in more serious degradation of the PLA.

When ultrasound was applied on the PLA samples, it could be observed that when the treating temperature and time were fixed, the $[\eta]$ of ultrasound degraded PLA was

smaller than that of only thermal degraded PLA. This indicated that ultrasound could induce the degradation of PLA and promote the decrease of the $[\eta]$ of PLA, and the process in which ultrasound was applied could be named as ultrasound degradation. Fig. 3 also showed that with the increase of the heating time, the difference of intrinsic viscosity between the ultrasound degraded PLA samples and the thermal degraded PLA became greater. So it could be understood that if the treating time was longer, the effect of ultrasound on the degradation of PLA was more obvious.

Further experiment was carried out to investigate the dependence of $[\eta]$ of PLA on the ultrasound time. All PLA samples were treated under a fixed temperature for 60 minutes. In the 60 minutes, first 5 minutes was used to make the PLA granules melting and then the PLA melts would be treated by ultrasound for 5, 25 and 55 minutes, respectively. After ultrasound treatment, the PLA melt should be kept in the cavity for 50, 30 and 0 minutes, respectively. In this process, the treating time of all samples was the same in total, thus the effect of ultrasound on the degradation of PLA could be studied excluding the effect of heat on the degradation. As was shown in Fig. 4, when the ultrasound time was fixed, the intrinsic viscosity of PLA decreased with the increase of the treating temperature. When the treating temperature was fixed, the intrinsic viscosity of PLA decreased with the increase of ultrasound time. It could be found in Fig. 4 that in the period from 0 to 25 minutes, the decrease of $[\eta]$ of PLA was more serious with the increase of temperature; however, in the period from 25 to 55 minutes, the rate of the decrease of $[\eta]$ of PLA was nearly same.

GPC

The effect of ultrasound time on molecular weight and the molecular weight distribution of PLA was shown in Fig. 5. The data showed that, the molecular weight M_w decreased with the increase of ultrasound time. When there was no ultrasound applied in degradation, the molecular weight distribution was wide. It was interesting that, when ultrasound was introduced in degradation, the molecular weight distribution became narrower at first and then it broadened with the increase of ultrasound time. Generally, in traditional thermal degradation, the molecular weight distribution would increase with the increase of degradation time [39] so the results from Fig. 5 indicated that the molecular structure development of PLA in the ultrasound degradation process was different from that in the thermal degradation process.

FTIR Analysis

In order to understand the molecular structure development of PLA in the ultrasound degradation process, the PLA samples treated and untreated by ultrasound were characterized through Fourier-transform infra-red spectroscopy (FT-IR).

The FT-IR spectra of the PLA samples, which were prepared at 170°C for 60 minutes, were listed in Fig. 6. It could be observed that there was no new absorption peak in the curves for the ultrasound degraded PLA samples and there were only some differences of the height and area of the characteristic peaks. It meant that there was no new type of functional group in ultrasound degraded PLA samples, but there was a change in the concentration of certain functional groups.

It was considered that the chain scission of PLA molecules occurred at the bond of

-C-O- in the ester group due to the process of ultrasound degradation, which was similar to the thermal degradation [40]. Therefore, the changes of the peak area of stretching vibration of C-O bond (1180 cm⁻¹) could be calculated to understand the variation of the structure of PLA in the degradation reaction. Since the methyl group did not change in the experiment, the area of the stretching vibration of methyl group (1453 cm⁻¹) was used as the internal standard.

From Fig. 7, it could be found that the content of -C-O- in the molecular chain, which was calculated from FT-IR results, decreased sharply when ultrasound was applied for short time, and then tiny increase was observed with the increase of ultrasound time.

Mechanism for Molecular Structure Development of PLA under Ultrasound

When PLA was under only heat treatment, the thermal degradation would lead to the scission of long molecular chains of PLA and then the molecular weight distribution of PLA became wide. However, when PLA was treated by ultrasound, the chain scission and the chain combination of PLA competed with each other in the ultrasound degradation process. The degradation process could be divided into two steps. At the first step, the viscosity was high and ultrasound preferred to tailor the long chain molecules into shorter ones, and the scission mostly occurred at the middle of the chain [17, 21]; so the effect of ultrasound on the chain scission of PLA was predominate. Thus it could be observed that at the initial stage of ultrasound degradation of PLA melt, the intrinsic viscosity decreased greatly and the molecular weight distribution became narrow due to the sharp decrease of high molecular weight chains. At the second step, with the increase of ultrasound time, the effect of

ultrasound on the chain combination of PLA became predominate; so the polymerization of fragments would be initiated by ultrasound and some new molecular chains with different length would be produced, resulting in the broadening of the molecular weight distribution. According to the discussion above, it could be concluded that scission and combination reactions coexisted in the course of ultrasound degradation of PLA melt. Total course of ultrasound degradation of PLA was illustrated in Fig. 8.

Thermal behaviors of PLA prepared by different methods

The application of PLA was related to its thermal property, which was determined by the molecular structure. Therefore, DSC was used to understand further the effect of heat and ultrasound on the molecular structure development of PLA. From Fig. 9, it could be seen that with the effect of ultrasound, the cold crystallization temperature and the melting temperature decreased. The exothermic peak for cold crystallization of thermal degraded PLA was wide and flat; while the exothermic peak of ultrasound degraded PLA became narrow and sharp. It could be found from Table 1 that the difference between T_{m1} and T_{m2} of the ultrasound degraded PLA was bigger than that of thermal degraded PLA. At the same time, the melting peak at the higher temperature became stronger than that at lower temperature.

The results from DSC were consistent with that from the other measurements and it could confirm the mechanism proposed for the molecular structure development of PLA under the effect of ultrasound. After the degradation, the macromolecules chains would break down into shorter chains. The decrease of the melting temperature

should be ascribed to the increase of the number of short chains, since the short chains could crystallize at lower temperature. When ultrasound was applied, the lower melting temperature of the ultrasound degraded PLA samples indicated that the ultrasound degraded PLA had more short chains than that of thermal degraded PLA. As reported by Kishore and Vasanthakumari [44-45], if the molecular weight of PLA decreased, the growth rate of the radius of crystal would accelerate and the crystallinity would be greater. It could be found from Table 1 that the crystallinity (X_c) of the ultrasound degraded PLA was higher than that of thermal degraded PLA. The narrow and sharp exothermic peak of ultrasound degraded PLA indicated that ultrasound could tailor the molecular chains into the short ones with narrow distribution which could crystallize at lower temperature. The differences between the DSC curves of thermal degraded PLA and ultrasound degraded PLA should be ascribed to the different molecular structures. In the future, further studies will be done to understand the effect of ultrasound on the crystallization properties of PLA.

Conclusion

In this paper, the effect of ultrasound on the molecular structure development of PLA was studied. Ultrasound had great influence on the intrinsic viscosity and molecular structure of PLA. In our experiment, the intrinsic viscosity of PLA decreased with the increase of treating time, ultrasound time and treating temperature. Different from the traditional thermal degradation, ultrasound could induce the degradation of PLA and it could also initiate the combination of the fragments. New mechanism was proposed to explain the molecular structure development of PLA melt in the presence of

ultrasound and the mechanism could be confirmed further by the thermal property of PLA from the DSC results.

Acknowledgements

Financial supports of the National Natural Science Foundation of China (50933004, 21174091 and 51121001), Program for Changjiang Scholars and Innovative Research Team in University (IRT1163) and RCUK Bradford Science Bridges China/EPSRC Global Engagements are gratefully acknowledged.

References

1. Bodmeier R.; Oh K. H.; Chen H. The effect of the addition of low molecular weight poly(dl-lactide) on drug release from biodegradable poly(dl-lactide) drug delivery systems. *Int J Pharm* 1989; 51(1): 1-8.
2. Coffin M.D.; McGinity J.W. Biodegradable Pseudolatexes: The chemical stability of poly(D,L-Lactide) and poly(ϵ -Caprolactone) nanoparticles in aqueous media. *Pharm Res* 1992; 9(2), 200-205.
3. Martin O.; Averous L. Poly(lactic acid): plasticization and properties of biodegradable multiphase systems. *Polymer* 2001; 42(14): 6209-6219.
4. Virgilio N.; Sarazin P.; Favis B.D. Ultraporous poly(l-lactide) scaffolds prepared with quaternary immiscible polymer blends modified by copolymer brushes at the interface. *Polymer* 2011; 52(7): 1483-1489.
5. Rakmae S.; Lorprayoon C.; Ekgasit S.; Suppakarn N. Influence of heat-treated bovine bone-derived hydroxyapatite on physical properties and in vitro degradation behavior of poly (Lactic Acid) composites. *Polymer Plast Tech Eng*

2013; 52(10): 1043-1053.

6. Teamsinsungvon A.; Ruksakulpiwat Y.; Jarukumjorn K. Preparation and characterization of poly(lactic acid)/poly(butylene adipate-co-terephthalate) blends and their composite. *Polymer Plast Tech Eng* 2013; 52(13): 1362-1367.
7. Singla R.; Mehta R. Preparation and characterization of polylactic acid-based biodegradable blends processed under microwave radiation. *Polymer Plast Tech Eng* 2012; 51(10): 1014-1017.
8. Jiang S.; Liao G. Synthesis and characterization of biocompatible poly(ethylene glycol)-b-poly(L-lactide) and study on their electrospun scaffolds. *Polymer Plast Tech Eng* 2012; 51(12): 1237-1244.
9. Balakrishnan H.; Hassan A.; Imran M.; Wahit M. U. Toughening of Polylactic Acid Nanocomposites: A Short Review. *Polymer Plast Tech Eng* 2012; 51(2): 175-192.
10. Freiberg S.; Zhu X.X. Polymer microspheres for controlled drug release. *Int J Pharm* 2004; 282(1-2): 1-18.
11. Ladrón de Guevara-Fernández S.; Ragel C.V.; Vallet-Regí M. Bioactive glass-polymer materials for controlled release of ibuprofen. *Biomaterials* 2003; 24(22): 4037-4043.
12. Miyajima M.; Koshika A.; Okada J.; Kusai A.; Ikeda M. Factors influencing the diffusion-controlled release of papaverine from poly (l-lactic acid) matrix. *J Control Release* 1998, 56(1-3): 85-94.
13. Xiong L.; He Z. Preparation and in-vitro properties of mPEG/PLA microspheres

- loaded 5-Fluorouracil for controlled release. *Polymer Plast Tech Eng* 2013; 52(3): 268-272.
14. Behnoodfar D.; Dadbin S.; Frounchi M. PLA microspheres-embedded PVA hydrogels prepared by gamma-irradiation and freeze-thaw methods as drug release carriers. *Int J of Polym Mater and Polym Biomater* 2013; 62(1): 28-33.
 15. Nakamichi K.; Yasuura H.; Fukui H.; Oka M.; Izumi S.; Andou T.; Shimizu N.; Ushimaru K. A process for the manufacture of nifedipine hydroxypropyl-methylcellulose phthalate solid dispersions by means of a twin screw extruder and appraisal thereof. *Yakuzaigaku* 1996; 56(1): 15-22.
 16. Rothen-Weinhold A.; Besseghir K.; Vuaridel E.; Sublet E.; Oudry N.; Kubel F.; Gurny R. Injection-molding versus extrusion as manufacturing technique for the preparation of biodegradable implants. *Eur J Pharm Biopharm* 1999; 48(2): 113-121.
 17. Chen G.; Guo S.; Li H. Ultrasonic improvement of the compatibility and rheological behavior of high-density polyethylene/polystyrene blends. *J Appl Polym Sci* 2002; 86(1): 23-32.
 18. Wu H.; Guo S. Improved properties of metallocene-catalyzed linear low density polyethylene/polypropylene blends during ultrasonic extrusion *Chi J Polym Sci* 2007; 25(4): 357-364.
 19. Li J.; Guo S.; Li X. Degradation kinetics of polystyrene and EPDM melts under ultrasonic irradiation. *Polym Degrad Stab* 2005; 89(1): 6-14.
 20. Li J.; Liang M.; Guo S.; Lin Y. Studies on chain scission and extension of

- polyamide 6 melt in the presence of ultrasonic irradiation. *Polym Degrad Stab* 2004; 86(2): 323-329.
21. Peng B.; Wu H.; Guo S.; Lai S. Y.; Jow J. Static ultrasonic oscillations induced degradation and its effect on the linear rheological behavior of novel propylene based plastomer melts. *Polym Degrad Stab* 2007; 92(8): 1632-1639.
 22. Xie T.; Wu H.; Bao W.; Guo S.; Chen Y.; Huang H.; Chen H.; Lai S.Y.; Jow J. Enhanced compatibility of PA6/POE blends by POE-g-MAH prepared through ultrasound-assisted extrusion. *J Appl Polym Sci* 2010; 118(3): 1846-1853.
 23. Peng B.; Wu H.; Bao W.; Chen Y.; Huang H.; Lai S. Y.; Jow J. Ultrasound initiated maleic anhydride grafted onto a novel polypropylene copolymer. *Polym Eng Sci* 2012; 52(3): 518-524.
 24. Zhao L.; Li J.; Guo S.; Du Q. Ultrasonic oscillations induced morphology and property development of polypropylene/montmorillonite nanocomposites. *Polymer* 2006; 47(7): 2460-2469.
 25. Ryu J. G.; Park S. W.; Kim H.; Lee J. W. Power ultrasound effects for in situ compatibilization of polymer-clay nanocomposites. *Mater Sci Eng C* 2004, 24(1-2): 285-288.
 26. Kim H.; Lee J.W. Effect of ultrasonic wave on the degradation of polypropylene melt and morphology of its blend with polystyrene. *Polymer* 2002; 43(8): 2585-2589.
 27. Feng W.; Isayev A.I. In situ compatibilization of PP/EPDM blends during ultrasound aided extrusion. *Polymer* 2004; 45(4): 1207-1216.

28. Lee S.; Lee Y.; Lee J. W. Effect of ultrasound on the properties of biodegradable polymer blends of poly(lactic acid) with poly(butylene adipate-co-terephthalate). *Macromol Res* 2007; 15(1): 44-50.
29. Chaudhari P.D.; Uttekar P.S. Melt-Sonocrystallization: a novel particle engineering technique for solubility enhancement. *Int J Pharm Tech Res* 2009; 1(1): 111-120.
30. Luque de Castro M.D.; Priego-Capote F. Ultrasound-assisted crystallization (sonocrystallization). *Ultrason Sonochem* 2007; 14(6): 717-724.
31. Maheshwari M.; Jahagirdar H.; Paradkar A. Melt sonocrystallization of ibuprofen: Effect on crystal properties. *Eur J Pharm Sci* 2005; 25(1): 41-48.
32. Frank A.; Rath S.K.; Venkatraman S.S. Controlled release from bioerodible polymers: effect of drug type and polymer composition. *J Control Release* 2005; 102(2): 333-344.
33. Kiortosis S.; Kachrimanis K.; Broussali Th.; Malamataris S. Drug release from tableted wet granulations comprising cellulosic (HPMC or HPC) and hydrophobic component. *Eur J Pharm Biopharm* 2005; 59(1):73-83.
34. Siegel S. J.; Kahn J. B.; Metzger K.; Winey K. I.; Werner K.; Dan N. Effect of drug type on the degradation rate of PLGA matrices. *Eur J Pharm Biopharm* 2006; 64(3):287-293.
35. Omelczuk M.O.; McGinity J.W. The influence of polymer glass transition temperature and molecular weight on drug release from tablets containing poly(DL-lactic acid). *Pharm Res* 1992; 9(1):26-32.

36. Omelczuk M.O.; McGinity J.W. The influence of thermal treatment on the physical-mechanical and dissolution properties of tablets containing poly(DL-lactic acid). *Pharm Res* 1993; 10(4):542-548.
37. Miller-Chou B.A.; Koenig J.L., A review of polymer dissolution. *Prog Polym Sci* 2003; 28(8):1223-1270.
38. Kopinke F.D.; Remmler M.; Mackenzie K.; Möder M.; Wachsen O. Thermal decomposition of biodegradable polyesters—II. Poly(lactic acid). *Polym Degrad Stab* 1996; 53(3): 329-342.
39. Wachsen O.; Platkowski K.; Reichert K.H. Thermal degradation of poly-l-lactide—studies on kinetics, modelling and melt stabilisation. *Polym Degrad Stab* 1997, 57(1):87-94.
40. Gupta M.C.; Deshmukh V.G. Thermal oxidative degradation of poly-lactic acid. *Colloid Polym Sci* 1982; 260(3): 308-311.
41. Hyon S.H.; Jamshidi K.; Ikada Y. Effects of residual monomer on the degradation of DL-lactide polymer. *Polym Int* 1998; 46(3): 196-202.
42. Reich G. Ultrasound-induced degradation of PLA and PLGA during microsphere processing: influence of formulation variables. *Eur J Pharm Biopharm* 1998, 45(2): 165-171.
43. Lim L.T. ; Auras R.; Rubino M. Processing technologies for poly(lactic acid) . *Prog Polym Sci* 2008; 33(8): 820-852.
44. Kishore K.; Vasanthakumari R.; Pennings A.J. Isothermal melting behavior of poly(L-lactic acid). *J Polym Sci Polym Phys Ed* 1984; 22(4): 537-542.

45. Vasanthakumari R.; Pennings A.J. Crystallization kinetics of poly(l-lactic acid).

Polymer 1983; 24(2): 175-178.

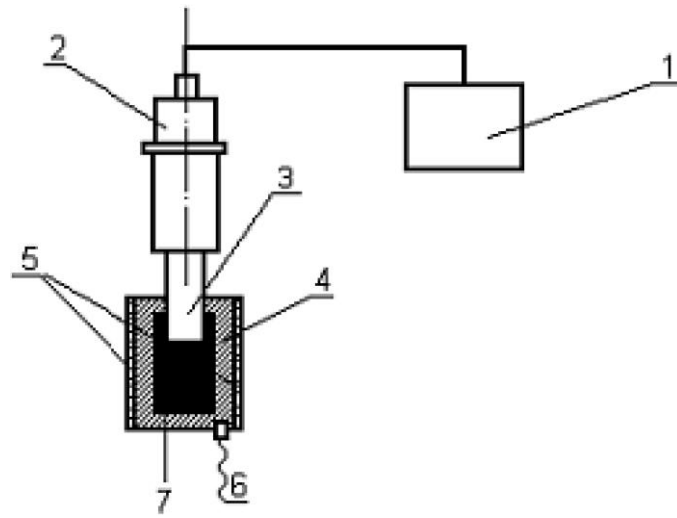

Figure 1 Scheme of the special ultrasound-assisted treater
1: Ultrasound generator; 2: Piezoelectric transducer; 3: Horn; 4: Die;
5: Electric heaters; 6: Thermocouple; 7: Melt

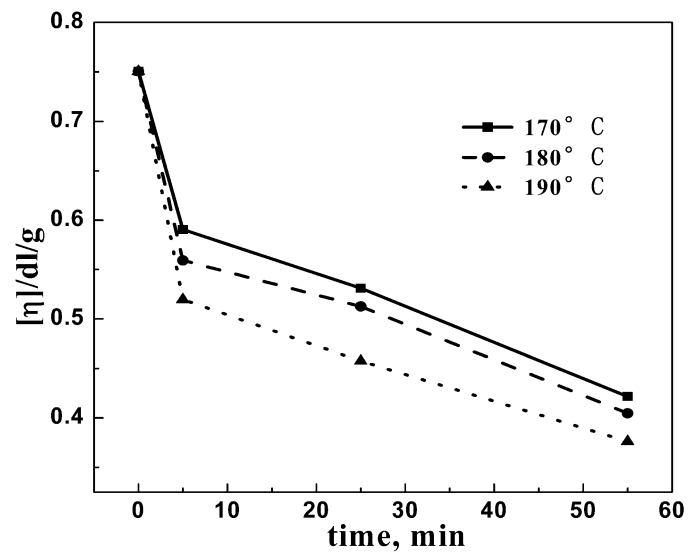

Figure 2 Effect of heating temperature and heating time on $[\eta]$ of PLA

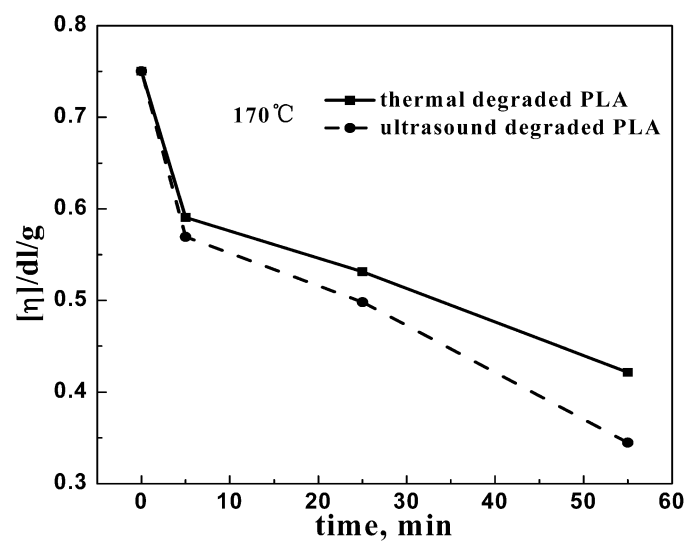

Figure 3 Effect of ultrasound on $[\eta]$ of PLA

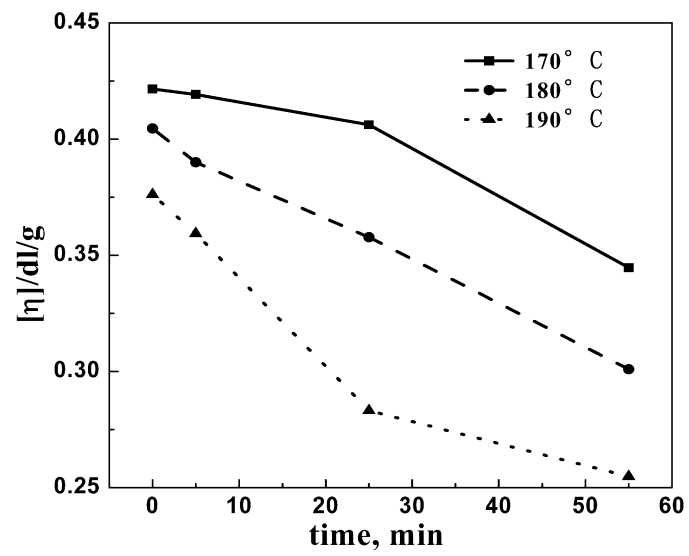

Figure 4 Dependence of $[\eta]$ of PLA on the ultrasound time at different temperatures

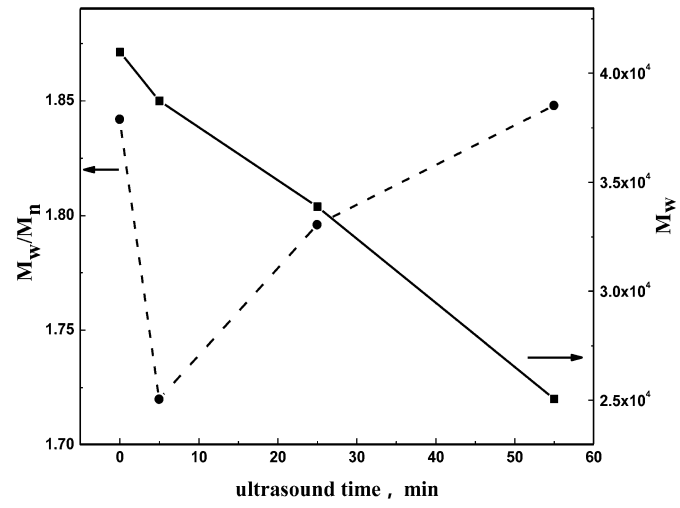

Figure 5 Effect of ultrasound time on M_w and M_w/M_n for PLA (treating temperature: 170°C)

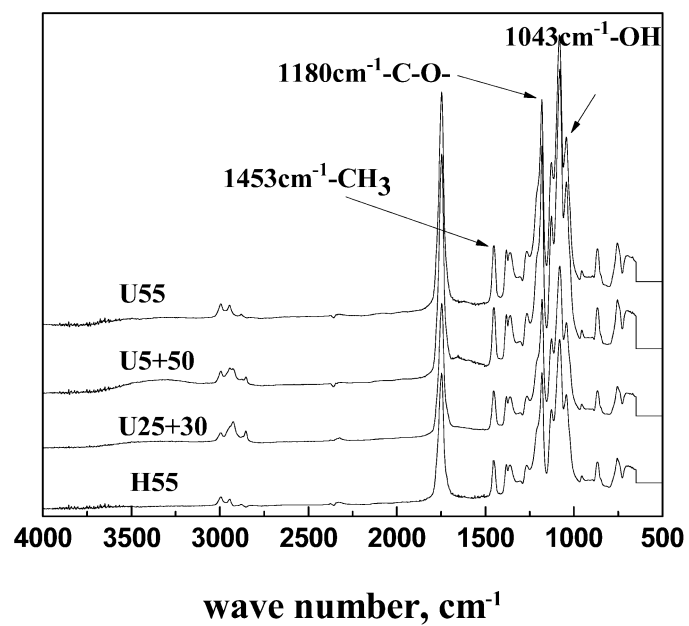

Figure 6 FT-IR spectra of PLA treated at 170°C (U55: treated by ultrasound for 55 minutes; U25+30: treated by ultrasound for 25 minutes; U5+50: treated by ultrasound for 5 minutes; H55: treated only by heating)

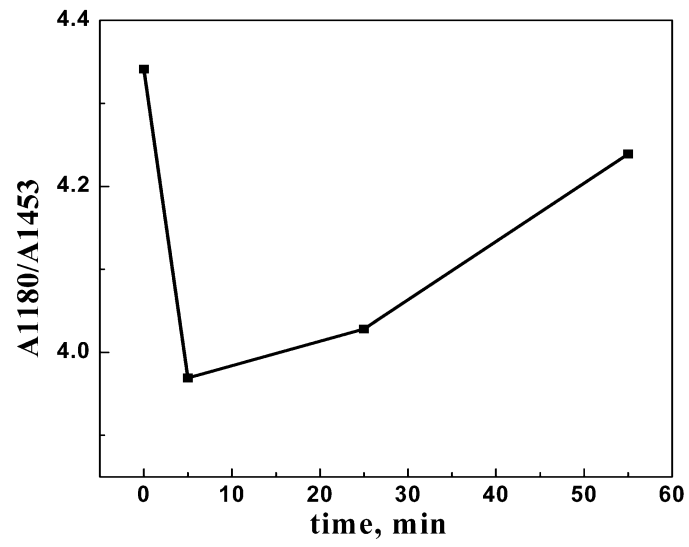

Figure 7 Dependence of A1180/A1453 on ultrasound time (treating temperature:
170°C)

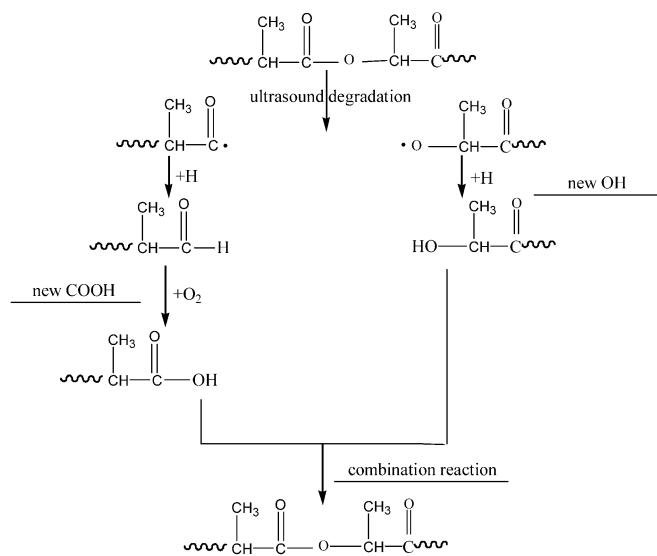

Figure 8 Mechanism scheme for the molecular structure development of PLA under ultrasound

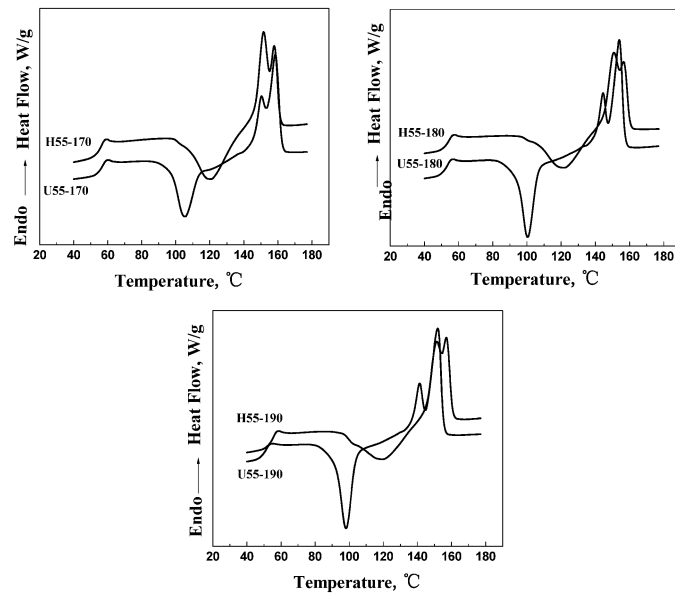

Figure 9 DSC curves of PLA samples prepared by different methods at different temperatures (H55: the PLA samples were treated only by heating for 60minutes; U55: the PLA samples were preheated for 5minutes and then treated by heating and ultrasound for 55minutes)

Table 1 The data of T_{cc} , T_{m_1}/T_{m_2} and X_c from DSC curves of PLA samples treated by different methods

Treating temperature, °C	Sample name	The temperature for cold crystallization, T_{cc} , °C	T_{m_1}/T_{m_2} , °C	X_c , %
170	H55	120.7	151.6/157.9	2.8
	U55	105.5	150.4/158.5	5.3
180	H55	121.9	150.9/156.5	4.6
	U55	100.4	144.5/154.0	9.0
190	H55	119.4	151.5/156.9	3.5
	U55	98.1	141.3/151.9	7.2