

bradscholars

Bond strength between corroded steel reinforcement and recycled aggregate concrete

Item Type	Article
Authors	Alhawat, Musab M.;Ashour, Ashraf
Citation	Alhawat MM and Ashour AF (2019) Bond strength between corroded steel reinforcement and recycled aggregate concrete. Structures. 19: 369-385.
DOI	https://doi.org/10.1016/j.istruc.2019.02.001
Rights	© 2019 Institution of Structural Engineers. Published by Elsevier Ltd. All rights reserved. Reproduced in accordance with the publisher's self-archiving policy. This manuscript version is made available under the Creative Commons CC-BY-NC-ND license (https://creativecommons.org/licenses/by-nc-nd/4.0)
Download date	2026-06-08 02:43:35
Link to Item	http://hdl.handle.net/10454/16849

Bond strength between corroded steel reinforcement and recycled aggregate concrete

Musab Alhawat
School of Engineering and informatics
University of Bradford
Bradford, BD71DP, UK
m.alhawat@bradford.ac.uk

Prof. Ashraf Ashour
School of Engineering and informatics
University of Bradford
Bradford, BD71DP, UK
a.f.ashour@bradford.ac.uk

Abstract

This paper investigates the bond performance of recycled coarse aggregate (RCA) concrete with un-corroded/corroded reinforcing steel bars, with the main parameters being RCA content, corrosion level, bar diameter and embedment length. For this purpose, 60 pull-out specimens containing different percentages of RCA (i.e. 0%, 25%, 50% and 100%) and steel bars of two diameters (12 and 20 mm) and different embedment lengths were tested. In order to establish various levels of corrosion, specimens were exposed to an electrochemical corrosion for 2, 5, 10 and 15 days. The bond strength between RAC concrete and un-corroded/corroded steel are compared to current codes and equations proposed by other researchers.

Experimental results showed that larger corrosion rate of steel bars was observed with the increase of the replacement level of RCA due to its high porosity and water absorption. The use of RCA had a slight influence on bond strength for un-corroded specimens compared to that obtained from conventional concrete. Furthermore, the bond strength of RCA concrete was strongly affected by corrosion products; bond strength slightly enhanced for up to 2% corrosion rate, and then significantly decreased as the corrosion time further increased, similar to that of conventional concrete. However, the rate of bond degradation between RCA concrete and corroded steel bars was much faster than that observed in corroded conventional concrete.

1. Introduction

With the increase of concrete utilization, there is a rapid growth in the consumption of natural aggregates that is the largest concrete component. It is estimated that the global consumption of natural aggregates (NCA) approximately 48.3 billion tons every year [1]. Simultaneously, the increasing amount of construction wastes has created a significant concern from the environmental aspect. It has been reported that about 850 million tonnes of construction and demolition wastes (CDW) are generated in

1 the EU countries every year, which are about 31% of total waste generation, causing serious
2 environmental issues accompanied by a shortage in landfills [2]. The use of recycled aggregate (RCA)
3 produced from CDW seems not only a promising solution for these serious issues, but can also assist
4 in reducing aggregate cost [3]. However, the quality of concrete containing RCA from CDW might be
5 inferior to those made with conventional aggregate [4, 5] due to the presence of old adhered mortar to
6 original concrete, leading to a porous, a higher absorption and cracks on the surface of RCA [6]. This
7 higher absorption capacity may cause some difficulties to control the fresh properties of concrete, and
8 consequently affects concrete durability and mechanical properties [3, 7]. However, results obtained
9 from some studies indicated that RCA can be partially used up to 30% as an alternative to natural
10 aggregate in concrete without affecting its properties [8].

11 Bond between steel reinforcement and surrounding concrete is one of the most fundamental properties
12 affecting the structural performance of reinforced concrete. Bond strength between steel and concrete
13 is mostly dependent on many parameters including; concrete strength, yield of reinforcement,
14 reinforcement size and geometry, bonded length, concrete cover, reinforcement position, the type of
15 used aggregate, and the presence of transverse reinforcement [9]. Corrosion of steel reinforcement
16 could significantly affect the bond in reinforced concrete, especially when the embedded steel bars are
17 severely corroded [10-13]. Steel reinforcement corrosion mainly causes volumetric expansion of
18 corrosion products, which is responsible for exerting the expansive radial pressure at the steel–concrete
19 interface. Corrosion may also lead to other deteriorations of concrete structures such as cracking and
20 reduction of effective steel cross-sectional area available for structural purposes [14].

21 The bond strength between concrete containing normal aggregate and reinforcing steel bars has been
22 extensively studied, nevertheless, relatively few studies have been carried out to determine the bond
23 characteristics between RCA concrete and deformed steel bars. Some of the available results reported
24 that the use of RCA in concrete does not have much effect on bond of steel reinforcing bars and
25 reinforced RCA concrete with a possible reduction of up to 10% compared to normal concrete [15, 16].

26 The possible reason could be that the bond strength is mainly affected by reinforcement properties such
27 as the surface profile and type of steel rebar rather than those related to aggregate properties [3].
28 However, some other researchers revealed that the bond strength could increase with increasing RCA
29 quantity in concrete [17]. The higher bond strength of RCA concrete might be associated to the increase
30 of friction resulting from the rough surface of RCA. Another possible reason might be attributed to the

1 internal curing influence of RCA resulting from further hydration when RCA is used in saturated surface
2 dry condition (SSD) [3]. [18] reported that the larger size of RCA in concrete might lead to less bond
3 strength between deformed steel and surrounding RCA concrete due to the presence of more air voids
4 in mixes.

5 Investigations in terms of bond strength between reinforcing steel and RCA concrete under corrosive
6 environments have been scarcely undertaken. Therefore, the main aim of the current paper is to study
7 the influence of RCA content on corrosion resistance of reinforcement embedded in concrete, in
8 addition to investigating the bond performance between RCA concrete and reinforcing steel bars, either
9 corroded or un-corroded using the pull-out test. For this purpose, the experimental investigations were
10 carried out on 60 pull-out specimens considering different parameters, namely RCA content, corrosion
11 level, embedded length of reinforcement and steel bar size. The obtained results for RAC concrete were
12 compared to those achieved from normal concrete, before finally being compared to current codes and
13 equations proposed by other researchers.

14 **2. Experimental program**

15 **2.1. Materials**

16 The main materials were Portland cement (CEM II), fine aggregate (NFA) and 20 mm maximum size
17 natural coarse aggregate (NCA). Recycled coarse aggregate derived from crushed washed
18 construction and demolition waste was used as a replacement to natural with a maximum size 20 mm.
19 Fig. 1 illustrates the two types of aggregate used in this research, while the typical characteristics of
20 RCA and natural fine and coarse aggregates are listed in Table 1. Fig. 2 shows the particle distribution
21 for both NCA and RCA, which conforms the requirement of BS EN 882, 1992 [19]. Two deformed steel
22 bars with diameters 12 and 20 mm were used in this study, conforming the requirements of BS 4449,
23 2005 [20] regarding ribs spacing, rib height and relative rib area.



Fig. 1. Aggregate types used in this study; (a) NCA, (b) RCA.

24
25
26
27
28
29

1
2

Table 1. Physical characteristics of used aggregate.

<i>Aggregate Type</i>	<i>Natural fine aggregate (NFA)</i>	<i>Natural coarse aggregate (NCA)</i>	<i>Coarse recycled aggregate (RCA)</i>
Maximum grain size (mm)	5	20	20
Specific Gravity	2.60	2.63	2.50
Water absorption (%)	2.10	1.06	4.4
Bulk density (Kg/m ³)	1580	1600	1360
Porosity (%)	-	40	46

3
4

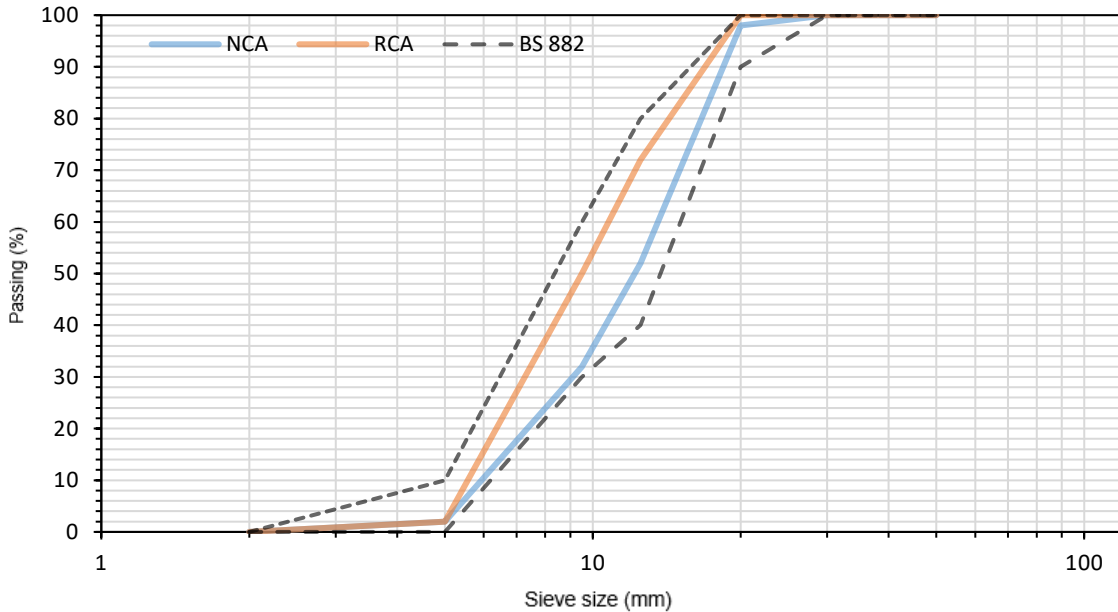

5

Fig. 2. Sieve analysis for RCA and NCA.

6

7

8

2.2. Specimen details

9

10

11

12

13

14

15

16

17

18

The pull-out test specimens were conducted according to RILEM CEB FIP (1983) [21] for a total of 60 specimens. The dimensions of the concrete cube specimens were 200mm*200mm*200mm with a single deformed steel bar centrally placed in the cubes. Three different series of pull-out specimens were carried out through this study as presented in Table 2 and Figure 3. Whilst the first and second series had a reinforcing bar of 12mm but having different bonded length, the third series was carried out with 20mm diameter bar having the same surface area as bars used in the second series. The bonded length of steel bars was selected to be five times of the bar diameter for the first and third series. The remaining length inside the cube was covered by a PVC pipe to ensure this part remained unbonded. The prominent length from the top was 310mm, while the lower part was isolated to prevent the bar from exposing directly to corrosion.

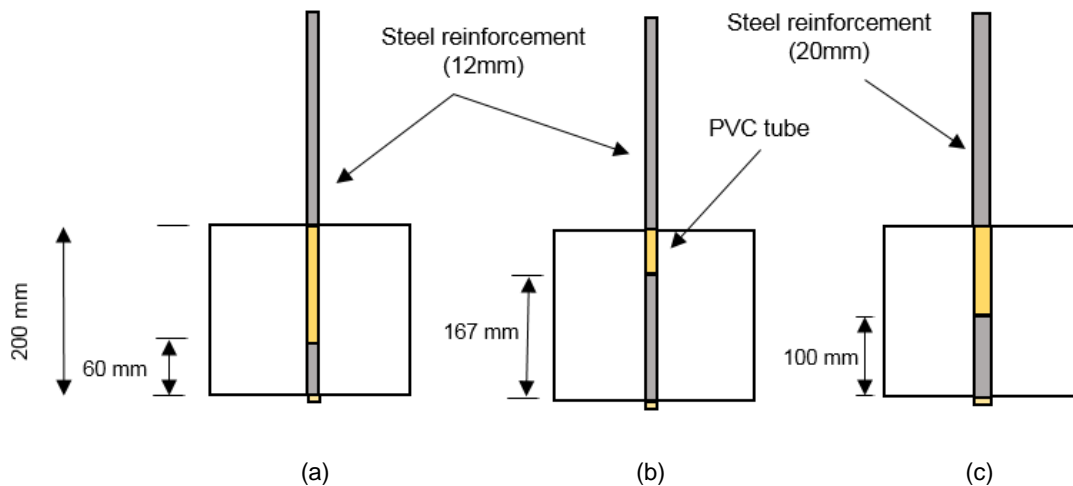

Fig. 3. Specimens test details; (a). \varnothing 12mm, l_d = 60 mm; (b). \varnothing 12mm, l_d = 167 mm; (c). \varnothing 20mm, l_d = 100 mm.

2.3. Concrete mix design, casting and curing

Four groups of concrete were adopted in this study with a constant w/b ratio but different levels of RCA as shown in Table 2. Natural coarse aggregate (NCA) was substituted by 0%, 25%, 50% and 100% of RCA. Each group of concrete mix consisted of three series of specimens (Fig. 3), and each series consists of five specimens. The first specimen from each series was tested after 28 days without exposing to any corrosion, whilst the others were tested after 2, 5, 10 and 15 days of corrosion acceleration. All concrete mixes made with the same water to binder ratio of 0.4, and the mix proportions were kept constant for all concrete mixes except replacing NCA with RCA. It should be noted that the amount of water required for aggregate to be in a saturated surface dry condition (SSD) was added to the mix by calculating the difference between water absorption and water content. After finishing the cast, the specimens were left 24h at room temperature before they were demoulded. Then, all the specimens were immediately covered by plastic sheets for 28 days until the day of test. The details of mix proportions are demonstrated in Table. 3.

Table 2. Description of tested specimens.

Group	RCA %	\varnothing	l_d	Period of corrosion (days)
I	0	12	60	0, 2, 5, 10, 15
		12	167	0, 2, 5, 10, 15
		20	100	0, 2, 5, 10, 15
II	25	12	60	0, 2, 5, 10, 15
		12	167	0, 2, 5, 10, 15
		20	100	0, 2, 5, 10, 15
III	50	12	60	0, 2, 5, 10, 15
		12	167	0, 2, 5, 10, 15
		20	100	0, 2, 5, 10, 15
IV	100	12	60	0, 2, 5, 10, 15
		12	167	0, 2, 5, 10, 15
		20	100	0, 2, 5, 10, 15

Table 3. Mixture proportion of concrete.

w/b	Materials (Kg/m ³)			
	NCA	NFA	Cement	Water
0.4	1180	664	450	180

2.4. Corrosion acceleration and testing procedure

Corrosion of steel in concrete is a slow process which may need a long time for reinforcement embedment to be corroded under natural conditions. With the limitation of time in performing the laboratory investigations, different techniques have been proposed to induce corrosion in a short period of time such as wet/drying technique, artificial climate environment technique, and impressed current/voltage acceleration technique [22]. Corrosion obtained by the latter is not fully simulative to that occurs in nature due to the difference in the electrochemistry behind the mechanism [23], in addition to the possibility of inducing more uniform corrosion along the surface of steel bar than that achieved under a natural environment [22]. However, a similar pattern of localized corrosion was obtained by impressed current technique with that occurs in real structures [24]. The impressed voltage technique has been adopted in this study owing to its advantages in saving time and cost in addition to the ability to control the corrosion rate through a test period by adjusting the applied voltage. The specimens were placed in plastic tanks containing 3.5% sodium chloride solution by weight of water to simulate the concentration of chloride in seawater [25, 26]. Pull-out specimens were placed inside plastic tanks, and approximately immersed up to 90% of their volume in NaCl solution. Each group of specimens was connected in parallel with DC power supply, and stainless steel bar was placed inside the tank to work as cathode, while steel reinforcement was used to act as anode. A constant voltage of 12V was applied to each specimen from a DC power supply for 2, 5, 10 and 15 days. As the concrete resistivity varied due to the variation of exposure time, the impressed current intensities ranged between 30mA to 270mA, generating different levels of corrosion as shown in Fig. 7. It should be noted that specimens with steel bars having 12mm diameter and 60mm bonded length recorded the lowest corresponding current intensity during all time of exposure, whereas higher current was observed with increasing bonded area, regardless of concrete ingredients. Moreover, the corresponding current for all specimens raised with the increase of exposure time, especially for specimens having longer embedment length during the period between 10-15 days, where some wide cracks were observed.

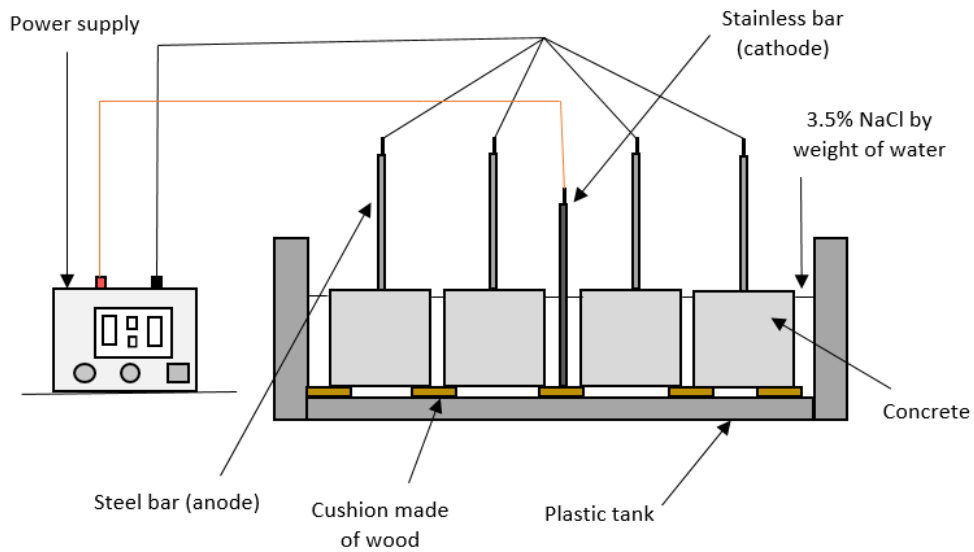

Fig. 4. Accelerated corrosion technique.

2.5. Concrete properties

Slump test was performed to measure the workability of fresh concrete in accordance with BS EN 12350-2, 2009 [27]. The compressive strengths of each mix were measured at 7, 28 and 90 days of curing in accordance with BS EN12390-3, 2009 [28] using (100 mm*100 mm *100 mm) cubes. Tensile test was conducted in accordance with BS EN 12390-6, 2009 [29] using cylindrical samples (300*150mm) and applying compressive loads over the length of cylinder. Two-point loading method was applied to measure the flexural strength at 28 days for beam samples having the dimensions of 500*100*100 mm. Therefore, the span between the two applied loads was 100 mm, while the distance between the two supports was 400 mm. The average of three samples was reported in accordance with BS EN 12390-5, 2009 [30]. The water absorption and dry density were simply measured using the specimens of 100 mm cube in accordance with BS1881-122, 1986 [31] and BS EN 12504-1, 2009 [32], respectively.

2.6. Pull-out test

Pull-out tests were conducted for both un-corroded and corroded specimens using a Denison machine with a capacity of 500 KN as shown in Fig. 5. The specimens were placed between two plates, and a rubber sheet was placed between the plate and the surface of the specimen to ensure that a load stress was uniformly distributed to the face of specimen. A data logger was connected to high precision linear variable differential transducers (LVDTs) to measure the slip of steel bar against the applied load. The axial load was applied up to cause full debonding of specimens, and the slip between the steel bar and

1 concrete was recorded at a constant loading rate of 0.01mm/min. The bond strength, defined as the
 2 average bond stress along the bar length, is calculated by dividing the bond failure load by the bonded
 3 surface area of the steel bar as given by Eq. 1.

$$\tau_u = P / \pi D L \quad (1)$$

5 where τ_u is the bond strength, P is the applied load, D is the bar diameter and L is the
 6 bonded length.

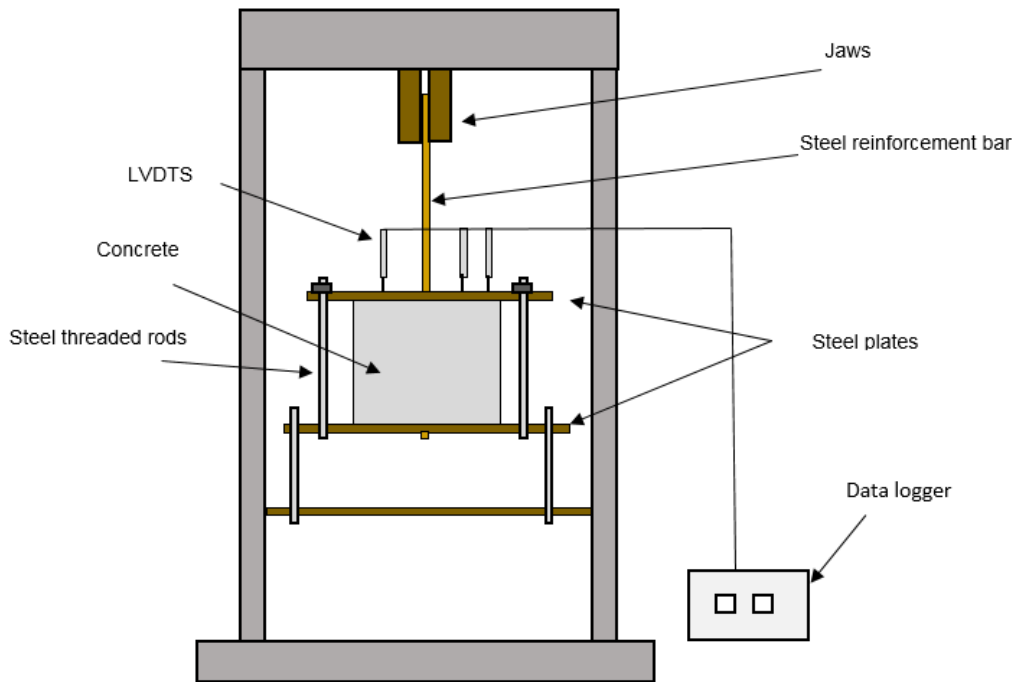

Fig. 5. Setup of the pull-out test.

2.7. Weight loss measurement

At the end of pull-out test, the corroded bars were taken out from concrete specimens and immersed in a hydrochloric acid solution, and subsequently cleaned by water and an iron brush as recommended by [33]. The weight of steel bar was recorded after removing the rust and compared to the initial weight of the bar before corrosion. The corrosion level was calculated by Eq. 2.

$$\eta = (G_1 - G_2) / g_0 * l_d * 100 \quad (2)$$

where η is the corrosion level of reinforcing steel bars, G_1 and G_2 are the weights of steel bar before and after corrosion, respectively, g_0 is the weight per unit length of reinforcing bar and l_d is the bonded length.

1 **3. Test results and discussion**

2 **3.1. Influence of RCA replacement level on concrete properties**

3 Fig. 6 demonstrates the relationship between RCA content and compressive strength of concrete at
4 different ages. It can be observed that there is a gradual reduction in compressive strength with the
5 increase of RCA. As expected, the compressive strength of conventional concrete recorded the highest
6 value at 7 and 28 days compared to other mixes. On average, concrete made with 25% RCA exhibited
7 quite similar results with those obtained by normal concrete, agreeing with other investigations that
8 showed that the use of up to 30% RCA has almost no effect on concrete properties [34, 35]. However,
9 RCA had more contribution to reducing the strength of concrete when the level of replacement
10 increased to 50% and 100% recording approximately 8.5% and 15% reduction, respectively, compared
11 to conventional concrete. Similar trend was reported by others [36, 35, 37], who found that the use of
12 100% RCA can lead to a reduction between 10% and 30% compared to the conventional concrete. This
13 reduction might be explained by the presence of old cement matrix adhered to the original aggregate,
14 resulting in the formation of another interfacial transition zone (ITZ) between the old and new cement
15 paste, in addition to that located between the natural aggregate and old cement paste. Therefore, two
16 ITZs can be found in RCA concrete, whilst only one ITZ exists in normal concrete. The failure of RCA
17 concrete mainly occurs at these frontier zones, which are considered the weakest areas in concrete
18 matrix, making the bond between aggregate and the hydrated cementitious matrix weaker [38]. Micro-
19 cracks and fissures found on the surface of RCA can also contribute to making the concrete more
20 porous, causing more amount of water required to achieve the desirable workability, and as a result
21 compressive strength values would be decreased with the increase of w/b ratio in the matrix. As time
22 of curing extended to 90 days, the rate of strength gain was slightly better for RCA concrete than that
23 achieved by normal aggregate concrete. This can be observed by comparing the improvement achieved
24 over time for concrete made with 50% and 100% RCA (9.5%, 11.5%), respectively, with that found with
25 normal concrete (8%), as similarly observed in previous studies [39, 40]. This might be attributed to
26 further cementing action of the remnant un-hydrated mortar adhered to RCA, which may have
27 contributed to improving the strength in the long term. Additionally, the high amount of absorbed water
28 inside RCA particles can further assist in promoting the hydration process by providing internal curing.

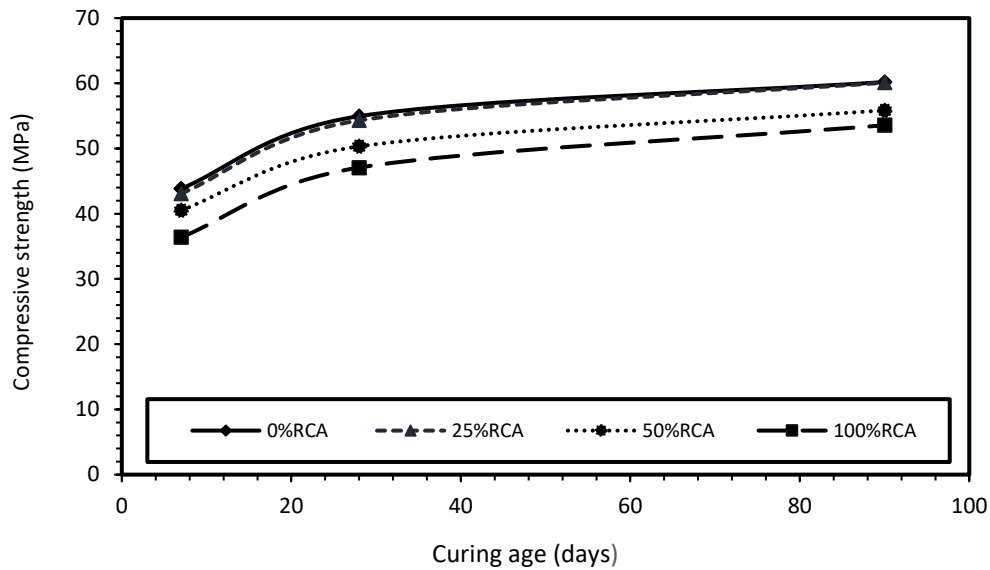

Fig. 6. Compressive strength at various ages with different levels of RCA.

1
2
3
4 The other main properties of RCA concrete (i.e. tensile strength, flexural strength, water absorption,
5 workability and density) were also investigated. As it can be seen from Table 4, the tensile strength and
6 flexural strength of RCA concrete were not significantly influenced by the replacement level of RCA.
7 Whilst using 25% and 50% RCA were quite similar to that obtained by normal concrete, 100% RCA led
8 to about 8% and 7% reduction in terms of tensile strength and flexural strength, respectively, following
9 similar trends reported by some authors [41, 3]. This is mainly because of these properties are mostly
10 dependent on the surface characteristics of RCA rather than the level of replacement. The water
11 absorption of RCA concrete was significantly affected by the RCA content, reflecting the water
12 absorption capacity of recycled aggregate. As the level of RCA replacement reached 100%, the water
13 absorption increased about 40% compared to the normal one. Therefore, it can be confirmed that the
14 durability properties of concrete are more deteriorated by the degree of RCA replacement than the
15 mechanical properties. It is also observed that the density of RCA concrete was approximately 8% lower
16 than that found with normal concrete. From Table 4, it can be also noted that the workability of RCA
17 mixes in terms of initial slump was marginally higher than that found in control mixes, which is consistent
18 with results obtained [42]. This might be explained by the increase of amount of free water required to
19 compensate the higher absorption capacity of RCA, and therefore time was not sufficient for RCA
20 concrete to absorb the extra water at the moment of slump test. However, after about 20 mins, all mixes
21 showed equivalent workability levels, suggesting that the compensating water had been completely
22 absorbed.

1 Table 4. The main properties of concrete mixes.

<i>Mix</i>	<i>Compressive Strength (MPa)</i>	<i>Tensile Strength (MPa)</i>	<i>Flexural Strength (MPa)</i>	<i>Water absorption (%)</i>	<i>Density (Kg/m³)</i>	<i>Slump (mm)</i>
0-RCA	54.66	2.99	4.05	3.74	2404.43	33
25-RCA	54.11	2.95	4.03	3.81	2385.04	33
50-RCA	50.33	2.87	4.0	4.56	2272.12	37
100-RCA	47.08	2.77	3.81	5.26	2193.51	40

2

3 **3.2. Influence of RCA replacement level on reinforcement corrosion**

4 Fig. 7 shows the relationship between the corrosion rate of specimens containing different levels of
5 RCA exposed to an electrochemical corrosion for 2, 5, 10 and 15 days. A wide range of corrosion
6 degrees was obtained in this study ranging from 1.34% up to approximately 20% weight loss. It can be
7 observed that the corrosion rate increases by increasing the level of RCA in concrete, especially, when
8 the level of RCA replacement reaches 100%. It can be also noted that all specimens made with 25%
9 RCA showed comparable corrosion rate results to normal concrete at all stages of corrosion exposure.
10 After two days of exposure to corrosion, 100% RCA led to 20%, 20% and 32% increase in corrosion
11 rate for the samples having embedded length 60, 167 and 100 mm, respectively, compared to those
12 containing normal aggregate. This increase continued for 100% RCA concrete with the extension time
13 of corrosion to five days reporting 4.88%, 5.68% and 3.46% weight loss, respectively, whilst the normal
14 concrete reached 3.95%, 4.59% and 2.11% at the same period. The influence of RCA quantity evidently
15 caused more corrosion as the period of corrosion exposure reached 10 and 15 days, reporting an
16 increase in corrosion rate exceeded 50% in some cases, compared to the normal concrete. This is
17 mainly attributed to the high porosity and water absorption of RCA, resulting from the presence of old
18 adhered mortar on the surface of aggregate. This means that the corrosion rate constantly developed
19 owing to the available of widening cracks on the surface of RCA concrete, allowing more chloride ions
20 to penetrate the concrete. Hence, the rust products readily accumulated on the surface of steel bar.
21 Another possible reason might be related to the presence of contaminants in RCA such as chloride,
22 carbonate and sulphate, which can de-passivate the protective layer located around steel bars [43]. It
23 can also be observed that more corrosion were spotted for both NCA and RCA concrete with specimens
24 having longer bonded length, making an increase in corrosion rate per unit length. For example, by
25 increasing the bond length from 60 mm to 167 mm, the corrosion rate per bond length for RCA
26 concrete devolved between 5- 20%.

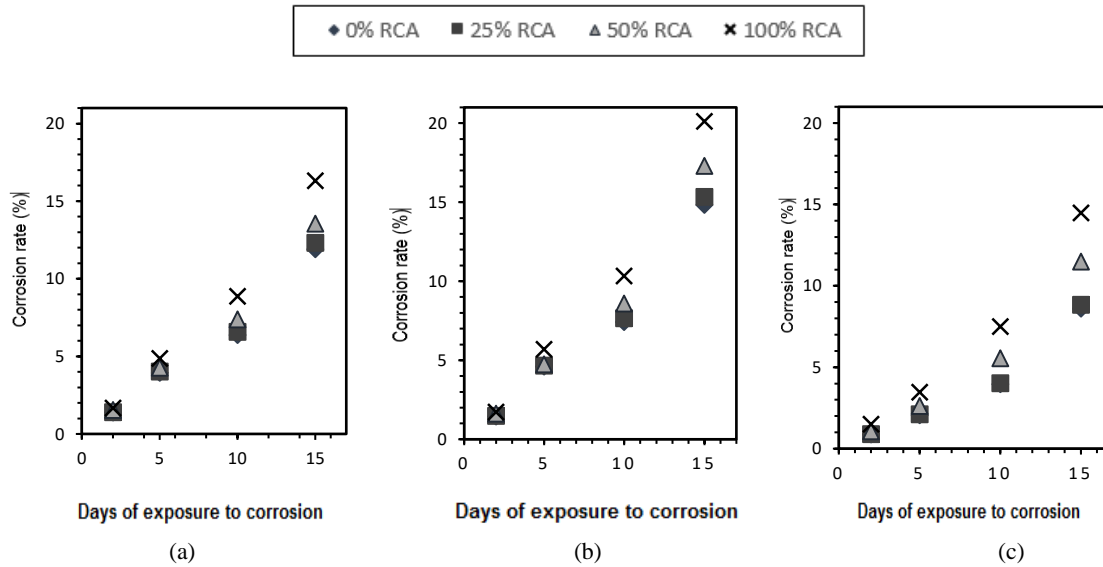

Fig. 7. Relationship between RCA content and corrosion rate for specimens having: (a). Ø 12mm, l_d = 60 mm; (b). Ø 12mm, l_d = 167 mm; (c). Ø 20mm, l_d = 100 mm.

3.3. Bond stresses-slip relationships

The measured bond stress versus slip curves for the three series of 100% RCA specimens at various degrees of corrosion is drawn in Fig. 9. By analysing the relationship between bond stress and slip of steel bars, it can be seen that the behaviour of bond stress of RCA concrete was quite similar to that found with conventional concrete for both cases; corroded and un-corroded, as also reported by [44]. For specimens having a short embedment length (60 mm), the relationship between bond stress and slip can be generally divided into three distinguished stages. In the first stage, the bond stress steeply increased with a very little slip ranged between 0 and about 1.5 mm until reaching the ultimate load. The second stage, which represents the first part of descending branch, exhibited a drop in the load after reaching the peak load accompanied by an increase in the bond slip. At the third stage, the bond stress slightly decreases with a rapid increase in the non-recoverable slip until the steel rebar completely pulled out. For specimens having 100 and 167 mm embedment length, the relationship between bond stress and slip showed some differences. This can be observed especially in the descending branch, showing a sudden drop after reaching the peak stress, resulting from splitting failure. It is also observed that for specimens with 167 mm embedment length either free or had a little amount of corrosion, a slight increase in the bond stress was observed after reaching about 91% of the ultimate stress accompanied by a rapid displacement, corresponding to steel yielding before pulling out from concrete.

1
2
3
4
5
6
7
8
9
10
11
12
13
14
15
16
17
18
19

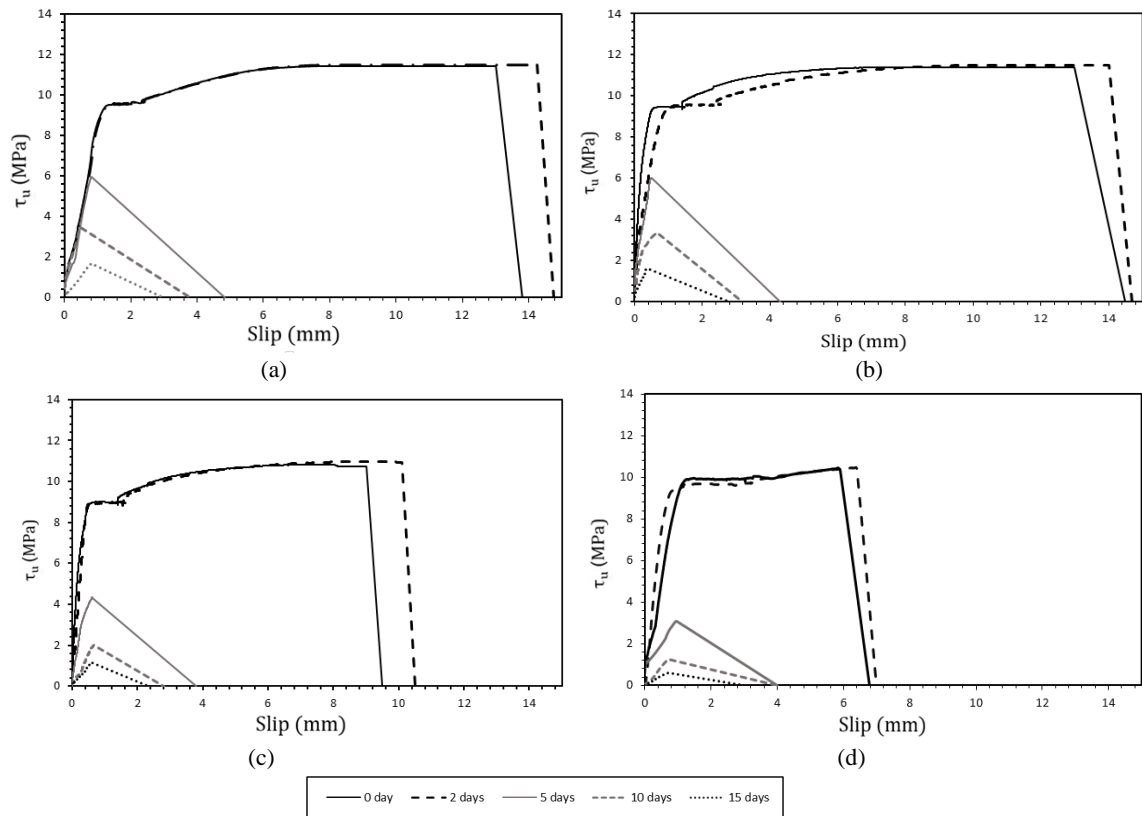
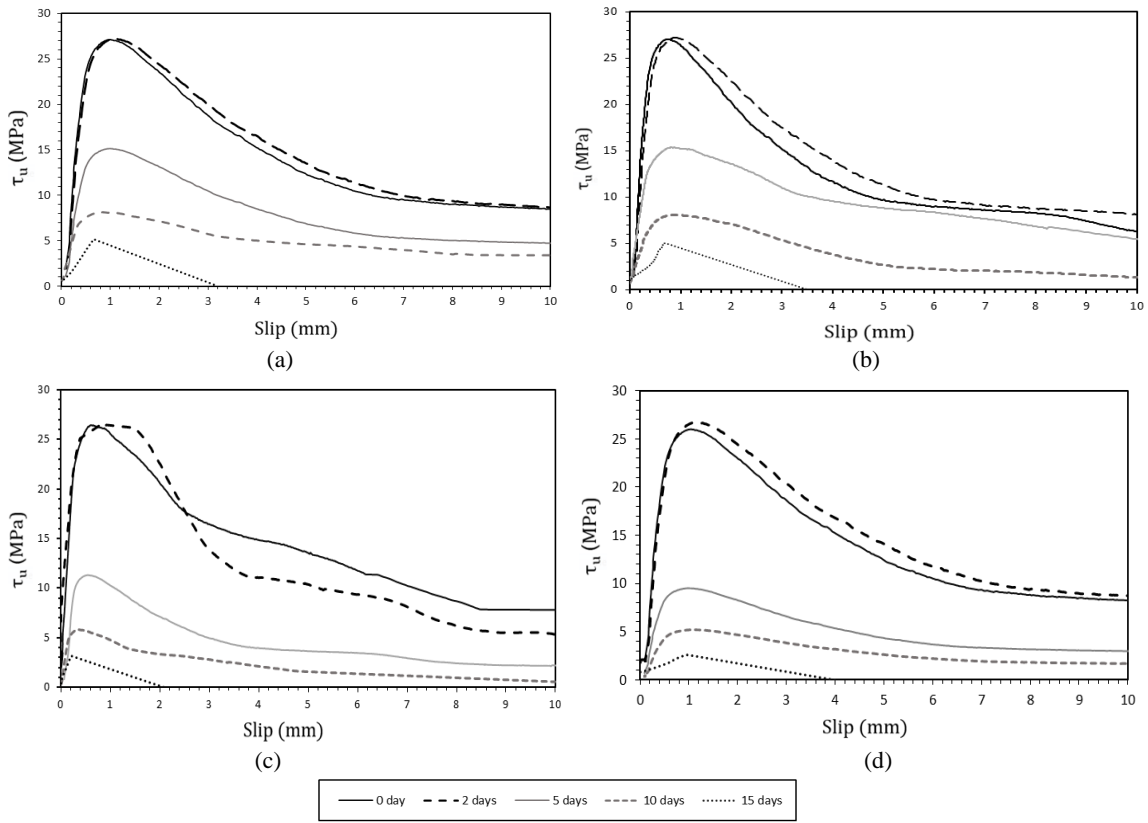

Fig. 8. Bond stress versus slip for specimens having \varnothing 12mm, $l_d=60$ mm and containing: (a). 0%RCA, (b). 25%RCA, (c). 50%RCA and (d). 100%RCA.

1

Fig. 9. Bond stress versus slip for specimens having \varnothing 12mm, $l_d=$ 167 mm and containing: (a). 0%RCA, (b).



2

25%RCA, (c). 50%RCA and (d). 100%RCA.

3

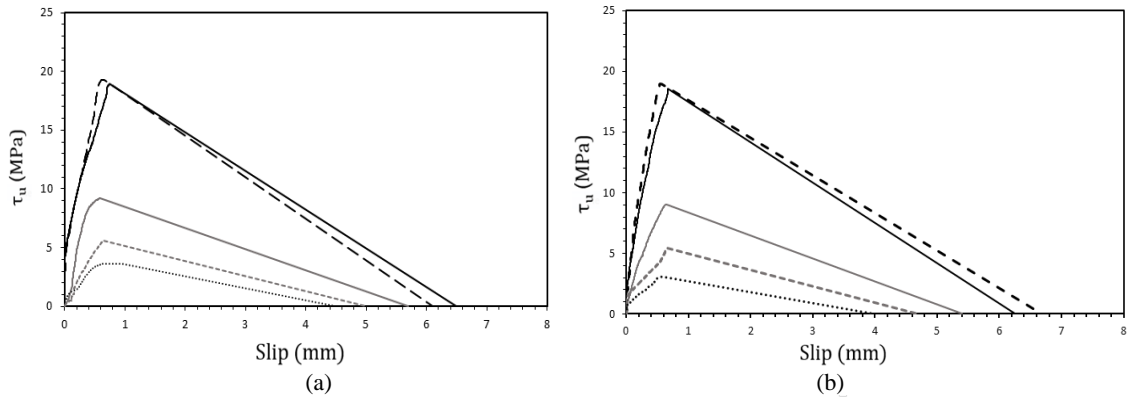

4

5

6

7

8

9

10

11

12

13

14

15

16

17

18

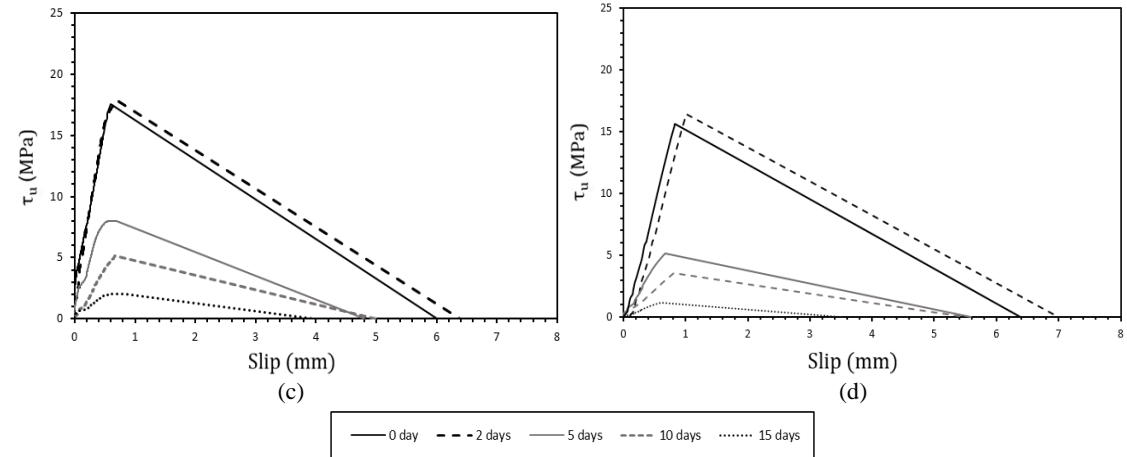

1 Fig. 10. Bond stress versus slip for specimens having \varnothing 20mm, $l_d=$ 100 mm and containing: (a). 0%RCA, (b).
2 25%RCA, (c). 50%RCA and (d). 100%RCA.
3

4 **3.4. Influence of RCA replacement level on bond strength**

5 From Fig. 10, it can be observed that the bond strength, in general, slightly decreases with the increase
6 of RCA level in concrete. For un-corroded concrete, it can be seen that bond strength between steel
7 reinforcement and concrete containing 25% RCA was almost similar to that found in conventional
8 concrete for all specimens. By using 50% RCA in concrete mixture, the bond strength after 28 days
9 reached 26.53 MPa for the samples having 60 mm embedded length, which represents approximately
10 97% of the bond strength of conventional concrete. Similarly, the other two specimens having
11 embedded length 167mm and 100mm reported about 95% bond strength compared to normal concrete.
12 For 100% RCA, it can be noted that the bond strength between 20mm deformed steel and RCA concrete
13 decreased approximately by 11% compared to normal concrete, whilst those containing 12mm steel
14 bar and having 60mm and 167mm bond length were less affected by reporting 6% and 9% decrease in
15 bond strength, respectively. The possible reason for this reduction might be attributed to the decrease
16 in the mechanical interlock and adhesive force with the increase of RCA ratio due to the presence of
17 micro-crack in RCA surface. Another possible reason for this reduction is the influence of compressive
18 strength on bond strength which is represented by the square root of compressive strength [9] These
19 results were in agreement with other authors [15, 16, 45] who found a reduction in bond strength by up
20 to 10% when NCA is fully replaced by RCA, while the use of both types of aggregate; recycled coarse
21 and fine aggregates leads to about 20% reduction in bond strength [46]. However, it was stated [47]
22 that the bond strength tends to increase in the presence of RCA. This might be due the roughness of
23 adhered mortar in RCA, which may increase the adhesion and friction mechanisms of bond strength at
24 the steel-concrete interface. In another investigation [44], it was reported that a slight higher bond
25 strength for RCA concrete when the compressive strength was similar to the normal concrete. It is
26 probably can be said that the bond strength of un-corroded steel reinforcement is less sensitive to RCA
27 replacement content than other influential factors such as steel surface profile and embedded length
28 [47, 3]. The influence of RCA content on bond strength continued almost the same after exposing to a
29 short period of an electrochemical corrosion (two days) to lead to about 10% reduction for the full
30 replacement of RCA. It is interesting to mention that through this stage (2 days) the concrete containing
31 50% and 100% RCA documented a slight better enhancement in terms of bond strength compared to
32 conventional concrete. For example, the bond strength between 167 mm bonded length and 100% RCA

1 enhanced by 1.8%, whilst the normal concrete showed just 0.8% improvement. This could be explained
 2 by the fact that bond strength during this stage was still in improvement due to the low degree of
 3 corrosion and the rust products were thicker between steel bar and RCA concrete than that found in
 4 conventional one, which was the same observation reported in [44]. With the extension of corrosion
 5 period to 5 and 10 days, the influence of using 25% RCA in concrete was negotiable on bond strength.
 6 However, this influence became clearer at 10 days for the samples containing 50% and 100% RCA,
 7 especially for larger embedded length (167mm) to obtain 58% and 36% from that stated in conventional
 8 concrete. This might be due to higher water absorption and porosity of these concretes, allowing more
 9 chloride ions to easily penetrate into a steel-concrete interface. Hence, more corrosion products are
 10 expected to accumulate on the surface of steel causing internal cracks, and consequently affect the
 11 performance of bond between steel and concrete. As time reached 15 days which represents harsh
 12 corrosive environments, bond strengths were obviously affected by RCA content. For instance, the
 13 bond strength between RCA concrete and 60mm
 14

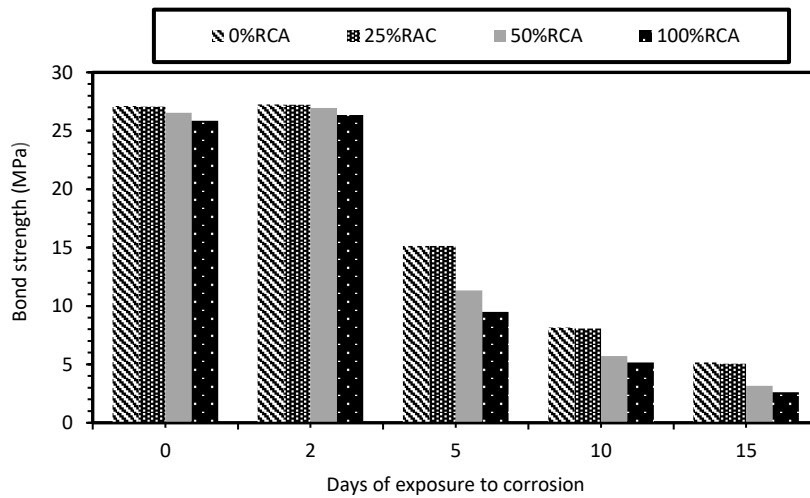

(a)

15
16

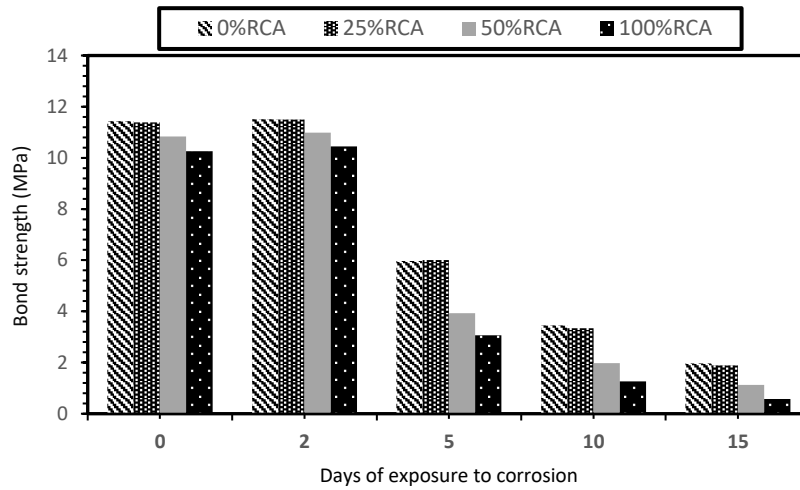

(b)

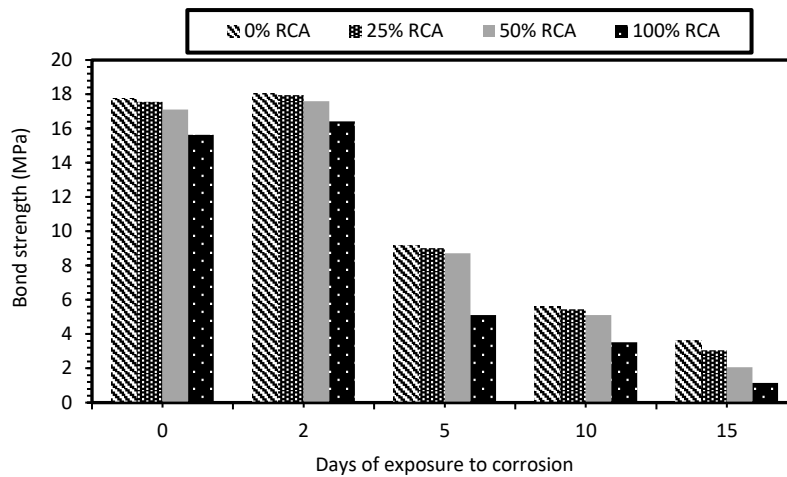

(c)

Fig. 11. Relationship between RCA content and bond strength for specimens having: (a). \varnothing 12mm, $l_d = 60$ mm; (b). \varnothing 12mm, $l_d = 167$ mm; (c). \varnothing 20mm, $l_d = 100$ mm.

bonded length represented about 50% of that found in normal concrete, whereas the degradation of bond between rebar 20mm and the same concrete was approximately 32% of normal concrete. This huge reduction owing to the appearance of widening cracks on the surface of RCA concrete around steel bar, while they were less observed with concrete containing normal aggregate. Nevertheless, [48] found that stirrups can effectively reduce the difference between NCA and RCA for uncorroded/corroded specimens. This is mainly attributed to the ability of stirrups on providing enough confinement and controlling the development of cracks resulting from corrosion.

3.5. Influence of corrosion on bond strength

The variation of bond strength due to corrosion has been investigated for four different periods of exposure starting with 2 days which represents a low amount of corrosion and finishing up with 15 days which represents severe environments. Data related to the influence of corrosion on bond strengths of

1 60, 167 and 100 mm bonded length are plotted in Fig.11. From the obtained results, it can be observed
 2 that bond strength is significantly influenced by steel corrosion for both types of concrete; normal and
 3 RCA concrete. However, it seems that the bond strength in RCA concrete is more sensitive to corrosion
 4 than conventional concrete. Bond strength slightly increased for all specimens after two days of
 5 corrosion acceleration when the corrosion rate ranged between 1.34% and 2%. The same observation
 6 was reported by other authors for NCA concrete [49, 10, 11], and even with RCA concrete [44], who
 7 found the corrosion products offer a favourable impact in terms of bond strength at lower corrosion
 8 values. This improvement may be explained by the increase of the surface roughness of steel
 9 reinforcement due to the creation of a firmly adhered layer of rust on the surface of steel reinforcement,
 10 which in turn enhances the radial stresses between the steel and surrounding concrete, and hence
 11 improving the frictional forces of bond. However, there is no consensus regarding the critical value of
 12 corrosion level as it was reported from 0.5% up to 2.4% weight loss [45, 12, 50]). The reason for this
 13 difference can be related to the difference in test set-up, the type of tested specimens, details of
 14 specimen and current applied to corrode the steel, and therefore parameters used in one experimental
 15 work might not be adequate to produce the same behaviour in other experiments. With a further of
 16 corrosion was produced at five days of corrosion, which can be classified as a pre-cracking stage, a
 17 loss in bond strength was observed for all specimens due to the development of corrosion rate to be
 18 between 2.5% and 5.6% weight loss. For instance, bond strength between normal concrete and 167
 19 mm bonded length distinctly declined from 11.44 MPa to 6.0 MPa at 4.15% corrosion rate. Similarly,
 20 bond strength of 100% RCA concrete with 20mm diameter bar decreased by about 50% as the
 21 corrosion rate reached 3.5%. This probably happened due to the lubricating influence of the flaky

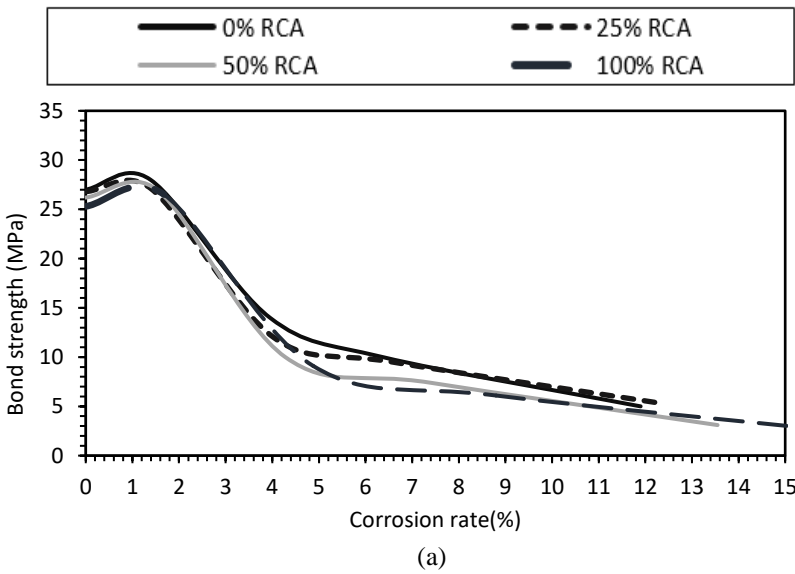

22
23
24

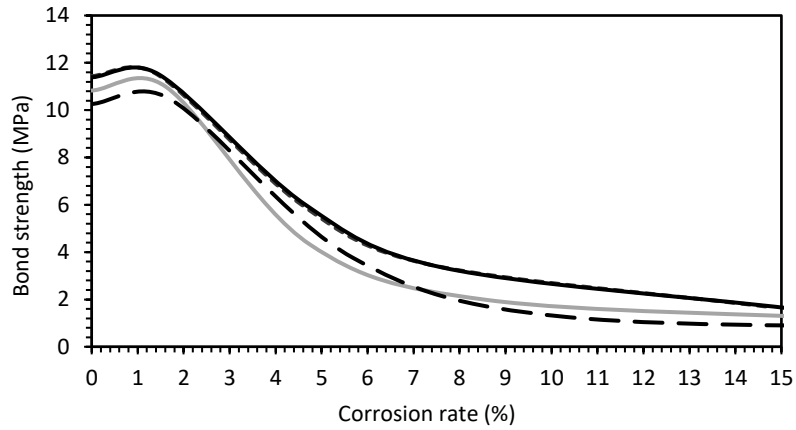

(b)

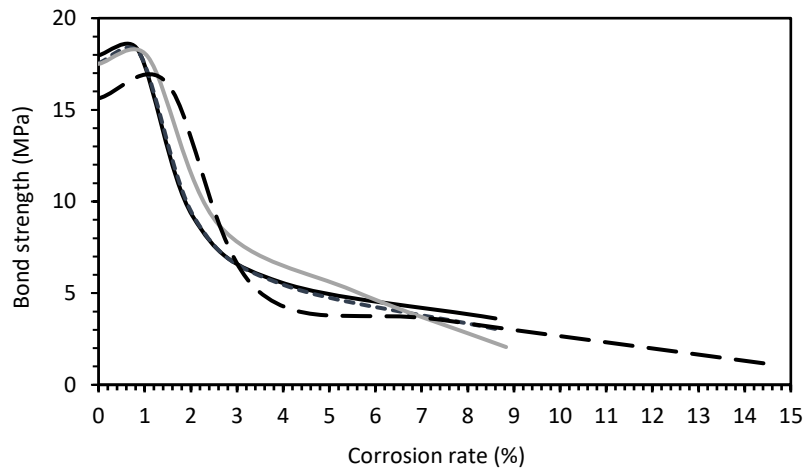

(c)

Fig. 12. Effect of corrosion rate on the bond strength of specimens having: (a). \varnothing 12mm, $l_d=60$ mm; (b). \varnothing 12mm, $l_d=167$ mm; (c). \varnothing 20mm, $l_d=100$ mm.

corroded layer on the steel surface, causing a change in the surface condition of the bar and reducing the friction force of bond strength. [51] linked the beginning of losing the bond at a steel-concrete interface with the appearance of cracks on the concrete surface. By reaching 10 days of corrosion acceleration, which can be classified as a cracking stage, the passivity of the protective film on the surface of steel was already completely destroyed due to the high rate of corrosion, reaching 10% in some cases. In this advancing levels of corrosion, the ribs height of reinforcing steel began degrading, causing more losing in bond strength, in addition to the appearance of some tight cracks on the external surface of concrete specimens. Extending time to 15 days, bond strength between 167mm bonded length steel bar and concrete containing 100% RCA was almost lost corresponding to the high rate of corrosion (20%), while less degradation observed with conventional concrete. During this stage, which can be described as a post- cracking stage, some interactive factors may have led to this huge loss in bond at the steel-concrete interface. In addition to the reduction in the bar section, the reinforcement

1 lugs were obviously destroyed up to a significant level in many samples, accompanied by the
2 observation of some longitudinal widening cracks. As a result, the mechanical interlocking force
3 between steel and surrounding concrete was almost lost. It is important to explain that the appearance
4 of cracks on RCA concrete surface could be delayed compared to normal concrete when they were
5 exposed to the same level of corrosion. It is stated that about 30% more time needed for the first crack
6 to be appeared on the surface of RCA concrete compared to normal concrete owing to the high porosity
7 of RCA concrete, which might offer more space for corrosion products to be stored before being cracked
8 [44].

9 **3.6. Influence of bar diameter on bond strength**

10
11 In order to investigate the influence of bar diameter on bond strength, two different bar diameters; 12
12 and 20 mm were used in this study, while two different cases of bonded length were carried out. In the
13 and 20 mm were used in this study, while two different cases of bonded length were carried out. In the
14 first case, the influence of bar diameter was investigated using the same surface area of embedment
15 length (6280 mm²), whilst in the second case, the bonded length for each bar was scaled five times of
16 bar diameter as recommended by RILEM CEB FIP, (1983) [21]. From Fig. 12, it can be obviously
17 shown that bar diameter significantly influences the performance of bond between reinforcing steel and
18 surrounding concrete. As the bar diameter increases, the bond strength is also increased as long as
19 the surface area of bonded length being constant. Before and after exposure to the initial corrosion, the
20 specimens with 12 mm bar diameter reported about 65% of the bond strength found with 20 mm. This
21 difference is mainly associated with the difference in the relative rib area of steel reinforcement, playing
22 a significant role in bond performance between the bar and its interaction with concrete. The relative
23 bar area, which is mainly governed by the specific combination of bar spacing and ribs height, can be
24 described as a ratio between the bearing area of projections above the core of bar to the shearing area
25 between the ribs (ACI 408, 2003) [9]. To clarify this, the ribs height and spacing are not exactly the
26 same for different diameter bars, and the bond resistance, in fact, is controlled by the blocking of ribs
27 in concrete. In the current study, the relative bar rib for 20mm steel bar (0.16) is found to be about 20%
28 higher than that reported for 12mm. This influence can be supported by the results obtained by [52]
29 who reported 40% enhancement in bond strength when the relative ribs increased from 0.04 to 0.1. The
30 ACI 408 (2003) [9] requirements for the maximum spacing between ribs equal to 70% of bar diameter,
31 and the minimum height of ribs equal to 4% and 5% from the nominal bars (12mm and 20 mm),
32 respectively, whilst the minimum recommendations for relative rib area equal to 1, with favourable
33 values between 1.7 up to 2. The influence of relative bar rib is found to be more pronounced with the

1 presence of transverse confinement [53]. Findings obtained in this study can be supported by [37] who
 2 found about 24% development in the failure load when the relative bar rib increased from 0.08 to 0.16.
 3 Another possible factor could be related to this difference is the yielding of 12 mm steel bars before
 4 reaching the failure, which in turn might have led to reducing the frictional properties, in addition to the
 5 possibility of affecting ribs geometry by reducing relative rib area (CEB-FIB, 2010). It was indicated [55]
 6 that a significant reduction in bond stresses for specimens yielded before reaching failure compared to
 7 the same samples having a higher strength reinforcement and did not yield. However, the findings
 8 obtained by [56, 57] indicated that just about 2% lower bond strength for the same situation, whilst 10%
 9 of bond strength was higher after reaching the yield when transverse reinforcements are applied. As
 10 the corrosion rate develops, the specimens seemingly became less sensitive to this parameter,
 11 especially in the advanced stages of corrosion. The likely reason is the erosion of reinforcement lugs of
 12 both bars which are responsible for transferring the force between steel and concrete, causing a
 13 decrease in transferring this force and making the influence of bar size less effect.

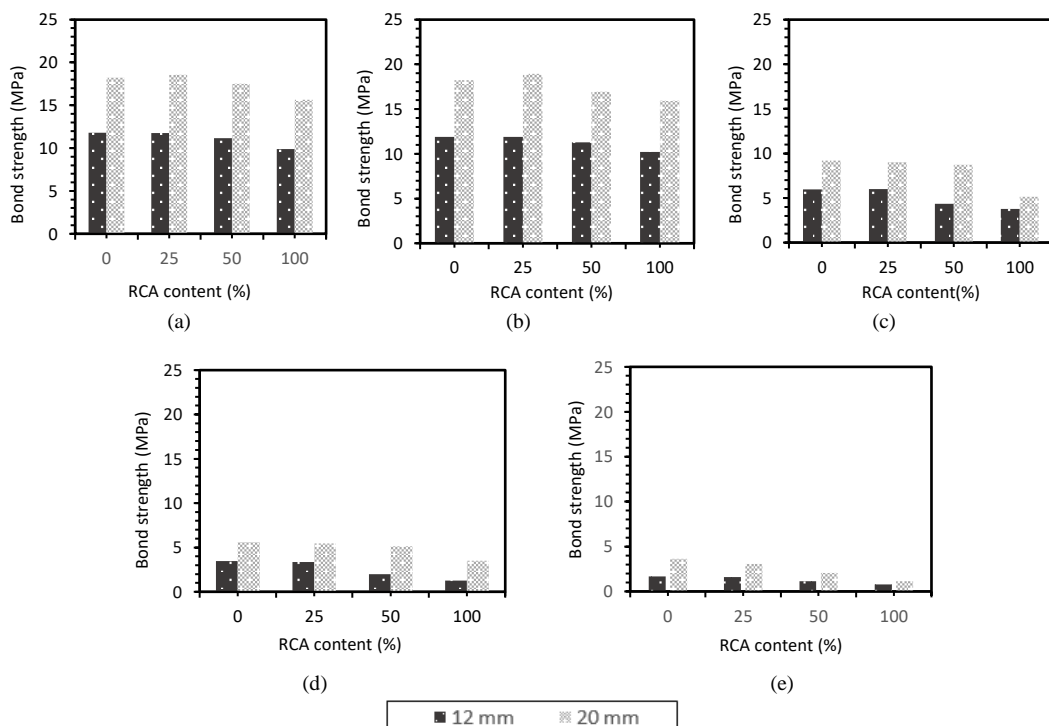

1
2
3
4
5
6
7
8
9
10
11
12
13
14
15
16
17
18
19
20
21
22

Fig. 13: Effect of bar size on bond strength of reinforced concrete.

With respect to using two different bonded length based on the size of used bar, the influence of bar diameter showed an opposite trend. From Fig. 13, it can be seen that bond strength of RCA concrete decreases as the bar diameter of reinforcing steel increases, similar observation found in normal concrete. For instance, at non-corrosion stage, the bond strength between 20mm reinforcing steel and RCA concrete containing 50% and 100% RCA reported approximately 60% and 63% of that obtained with 12mm, respectively, which can be supported by [58]. This can be explained by the difference in the surface area of bonded length between these two bars, in addition to the increase of the number and the volume of bleed water trapped pockets between the bars and concrete voids, causing an increment in the number of the voids and decreasing the contact area at a steel-concrete interface [59, 9]. The nonlinearity distribution of bond stress is more pronounced in larger bars (which requires a longer embedded length), resulting in a lower bond strength. By corroding the specimens for different periods, a similar behaviour was noted for both; NCA and RCA concrete. Similarly, [13] stated that bond strength reduced about 45% when the bar diameter increases from 12mm to 20mm, but the reduction being marginal when steel corroded. It is reported that influence of bar diameter on bond strength can be notably observed with low degrees of confinement, however, this impact almost disappeared with high degrees of confinement [60].

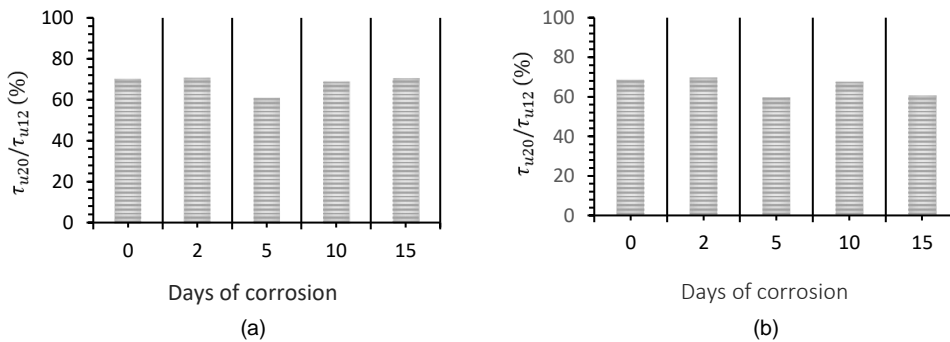

23
24
25

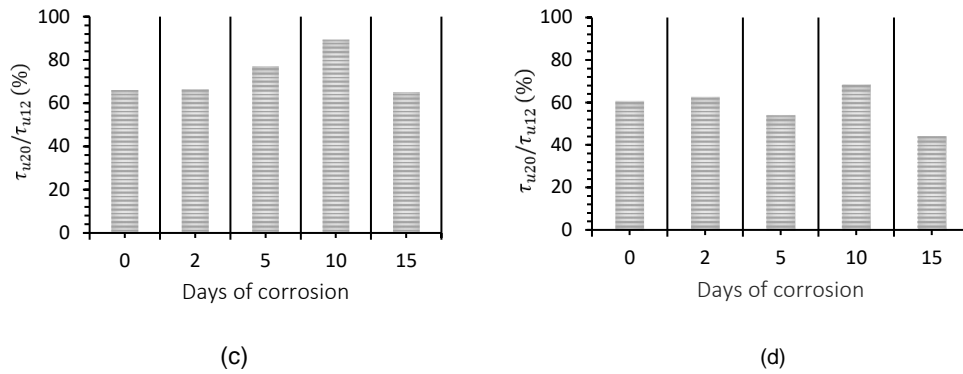

Fig. 14. Ratio of bond strength between the samples with bar 20mm and bar 12mm) for; (a). 0%RCA, (b). 25%RCA, (c). 50%RCA and (d). 100%RCA.

It can be probably concluded that the relationship between rebar diameter and bond strength cannot be always appreciated. This is fundamentally because of the embedment length is needed to be longer as bar diameter increases, while more bond forces are required for larger bars to be failed in the case of a given embedment length [9]. Similarly to normal concrete, the bar diameter of RCA concrete had a crucial influence on the failure mode of pull-out test' specimens for both corroded/uncorred steel bars. This can be observed when the samples having larger bar diameter (20mm) failed in splitting instead of pull-out failure observed with smaller bar diameters.

3.8. Influence of embedded length on bond strength

Based on the test results, it can be said that by increasing the development length of reinforcing steel, the ultimate force tends to be higher, however, the ultimate bond strengths obtained from both normal and RCA concrete specimens are clearly decreased. From Fig.14, it can be seen that the bond strength of specimens having an un-corroded embalmment length 5 times of bar diameter dropped by about 40% when the length increased to be 13 times of bar diameter. The same scenario was observed with concretes incorporating 50% and 100% RCA, recording approximately 37% and 35% of shorter bonded length, respectively. These findings confirms the earlier results obtained by [61], who reported 30-50% reduction in bond strength of RCA concrete when the embedment length doubled from 5d to 10d, where d is the bar diameter. This is mainly because of less bond stress is distributed along the bar when the embedment length increases, in addition to the increase of nonlinear distribution of bond stresses for larger embedment length, causing a reduction in bond strength. The other possible reason is associated with the increase of the number of bleed water trapped between a steel–concrete interface. Therefore, this increase in voids led to reducing the contacted area between the rebar and concrete. Hence, the average bond stress transferred to the surrounding concrete reduces when the bonded length

1 increases. It should be noted that increase in bond length will not always lead to an increase in the bond
 2 force, since the non-uniformly distribution of applied load reaches a marginal value close to zero at a
 3 certain distance, therefore a further increase in the embedment length will have no influence on the
 4 bond performance [26, 62]. After exposing to further corrosion, the degradation rate of bonding was
 5 higher for longer embedment length, and hence bond strength being more influenced by the change of
 6 bonded length. This might be occurred due to the presence of widening cracks resulting from corrosion
 7 along 167mm bonded bar, preventing the force from transferring between steel and concrete. The
 8 difference in embedment length also affected the failure mode of RCA concrete as the most specimens
 9 made with 5d bonded length failed by pulling-out the reinforcement, whilst the splitting failure was
 10 observed when the contacted area between steel and concrete was longer.

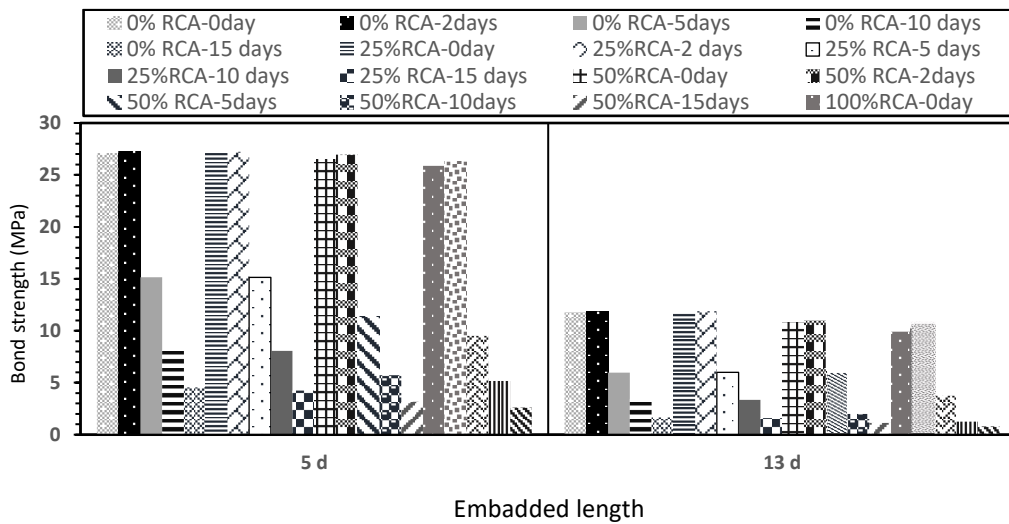

Fig. 15. Effect of embedded length on bond strength.

From Fig.15, it can be seen that there are three types of failure mode were observed during the experiential work. For specimens having 12mm bar diameter, pull-out failure as shown in Fig. 14(a) occurred for the majority of those having smaller embedded lengths (60mm) due to the availability of adequate confinement provided by the large cover of concrete (96mm). This type of failure takes place when the shear force generated from concrete exceeds the radial force of steel bar, allowing reinforcement steel to crush the keys of concrete located between each pair of lugs, and therefore reinforcement easily pulled out without any visible concrete splitting. However, this mode developed to be accompanied by splitting in concrete when the accelerated time for corrosion extended to 10 days as shown in Fig .14(b), because of the formation of some tiny cracks caused by corrosion products, making the confining action almost equiponderant with the radial forces of reinforcement [63]. By reaching 15 days of corrosion, the mode of failure turned into splitting owing to the presence of

1 longitudinal cracks, making concrete to be easily splitted. By increasing the embedment length for the
2 same bar (12mm) to be 13 \varnothing instead of 5 \varnothing (where \varnothing is the bar diameter), all specimens either; corroded
3 or un-corroded exhibited splitting failure as shown in Fig .14(c), indicating that the confining action
4 generated by the circumferential tensile forces in concrete was smaller than the radial force of steel bar.
5 Therefore, cracks are easily propagated at a steel-concrete interface until reaching the outer concrete
6 surface. By increasing the nominal bar diameter from 12mm to 20mm, the latter pattern failure was
7 observed with all tested specimens. It is important to explain that no differences between NCA and RCA
8 concrete specimens were observed in terms of failure modes, since little change in compressive
9 strength was reported. Therefore, the results confirmed that the failure modes are heavily controlled by
10 concrete strength, bar diameter, embedment length and rate of corrosion, rather than the type of
11 concrete used.



(a)

(b)

(c)

Fig. 16. Bond failure modes.

3.9. Concrete visual observation after corrosion

17 This part has only focused on the corrosion damage of reinforced concrete resulting from exposure to
18 aggressive environments (15 days of corrosion acceleration). It is generally accepted that the
19 mechanism of corrosion damage is fundamentally due to the formation of rust products (rustiness)
20 around steel reinforcement, occupying up to six times of original steel volume [64]. This expansion could

1
2



(a)

3
4



(b)

5
6



(c)

7
8

Fig. 17. Comparison of corrosion of steel in normal and RCA concrete for specimens having: (a). \varnothing 12mm, $l_d=60$ mm; (b). \varnothing 12mm, $l_d = 167$ mm; (c). \varnothing 20mm, $l_d = 100$ mm.

9 lead to internal tensile stresses in concrete, and as a consequence, cracking and spalling are expected
10 to occur on the surface of concrete [14]. Fig. 16 shows the difference between the specimens having
11 100% RCA and those containing only normal aggregate for the three types of used specimens. The
12 visual observations of these samples exhibited a localized rust with a brownish colour along the
13 periphery of embedded length of steel, while a wet orange oxide was spread over the internal surface
14 of concrete. Nevertheless, it can be noticed that the amount of fluid corrosion products for the three
15 types of specimens is more pronounced with RCA concrete, accompanied by a higher rate of steel
16 dissolution, compared to normal concrete specimens. This is primarily attributed to its higher

1 permeability and water absorption, allowing more moisture and chloride ions to reach steel-concrete
2 interface. This may be assigned to the formation of longitudinal cracks along the whole length of the
3 sample, allowing chloride ions to easily penetrate concrete matrix, and therefore the process of
4 corrosion was speeded up due to the large amount of electrons moving from cathode to anode sites.
5 These visible cracks were less available with the specimens having a shorter bonded length ($5 \varnothing$).

6 7 **4. Bond strength equations in code provisions and empirical equations**

8 **4.1. Bond strength between un-corroded bar and surrounding concrete**

9
10 Several researchers have proposed equations for predicting the bond strength between steel
11 reinforcement and surrounding concrete taking into account the main parameters such as compressive
12 strength, bar diameter, embedment length and concrete cover. The summary of these models is
13 presented in Table 4, and it should be noted that none of these equations were developed for RCA
14 concrete and they just were proposed based on the experimental results from specimens containing
15 only normal concrete. The bond strengths obtained from the experimental tests have been compared
16 to these equations, and presented in Fig.17. As shown in Table 5, the performance of predicted bond
17 strengths by the previous equations generally show conservative results compared to the experimental
18 results. It can be observed that using the predicted values of bond strength suggested by Darwin et al.
19 [64] and Orangun et al. [55] showed the closest results to the measured values with a mean ratio of
20 0.951 and 1.04, and a standard deviation (SD) of 0.28 and 0.341, respectively, while Esfahani &
21 Rangan's equation [66] was less accurate with a mean ratio of 1.22 and SD of 0.51, since concrete
22 cover, bar size and compressive strength were the only factors taken into account in this equation,
23 whilst the influence of embedment length is not included in the equation. Apart from results predicted
24 by CEB-FIP (2010) [54], all other equations give overestimated values for specimens having 167mm
25 embedment length compared to those experimentally obtained. However, the results obtained from
26 CEB-FIP (2010) formula for predicting splitting failure are significantly lower than those reported using
27 the formula of pull-out failure. It can be also noted that the weakness of CEB-FIP (2010) is mainly
28 attributed to the relying of the compressive strength of concrete for predicting the bond strength and it
29 does take into account for the effect of other significant parameters such as bar diameter and
30 embedment length. The influence of latter is not also covered by the equation proposed by the
31 Australian Standard (2004), and therefore the equation gives the same result at any length.
32

1 Table 5. Existing models for prediction bond strength by previous researchers.

Reference	Model	
CEB-FIP (2010)	$\tau_u = 2.5\sqrt{f'_c}$ at pull-out failure;	2
	$\tau_u = 7.0\left(\frac{f'_c}{25}\right)^{0.25}$ at splitting failure	3
Australian Standard 3600 (2004)	$\tau_u = 0.265\sqrt{f'_c\left(\frac{c}{d_b} + 0.5\right)}$	4
		5
Orangun et al., (1977)	$\tau_u = 0.083045\sqrt{f'_c\left(1.2 + 3.0\left(\frac{c}{d_b}\right) + 50\left(\frac{d_b}{L_d}\right)\right)}$	6
		7
Darwin et al., (1992)	$\tau_u = 0.083045\sqrt{f'_c\left(1.06 + 2.12\left(\frac{c}{d_b}\right)\right)\left(0.92 + 0.08\left(\frac{C_{max}}{C_{min}}\right) + 75\left(\frac{d_b}{L_d}\right)\right)}$	8
	where $C_{min} = \min(C_x, C_y, C_s/2)$, while $C_{max} = \max(\min(C_x, C_s/2), C_y)$, which C_x is the side cover, C_y is the bottom cover, and C_s is the spacing between the bars	9
Esfahani & Rangan (1998)	$\tau_u = 8.6\frac{C/d + 0.5}{C/d + 5.5}f_{ct}$	10
	where f_{ct} is the tensile strength of concrete taken as $0.55\sqrt{f'_c}$.	11

21
 22 It can be concluded that even though these equations exhibited reasonable trends for prediction the
 23 bond strength of NCA and RCA concrete, more parameters such as relative rib area and water
 24 absorption are needed to be involved in these empirical equations to improve the accuracy of bond
 25 value.

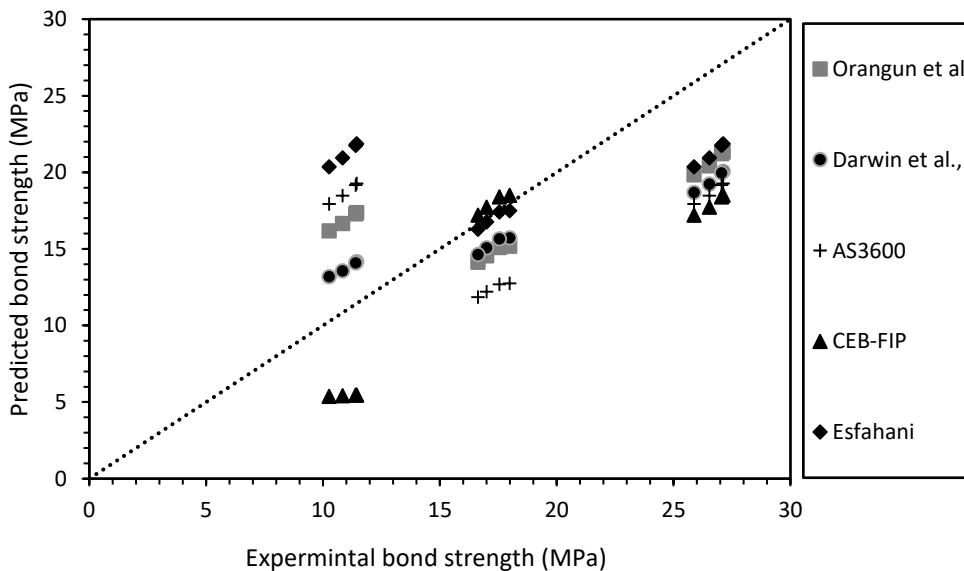

26
 28 Fig. 18. Experimental bond strengths versus predicted bond strength by some equations.

26
 28
 29

1 Table 6. Comparison of bond strength calculated from different equations with the experimental bond strength.

RCA%	f'_c	D	L	τ_{exp}	Darwin et al.,		Orangun et al		Esfahani		CEB-FIP		AS3600	
					τ_{theo}	$\tau_{(theo)_{exp}}$	τ_{theo}	$\tau_{(theo)_{exp}}$	τ_{theo}	$\tau_{(theo)_{exp}}$	τ_{theo}	$\tau_{(theo)_{exp}}$	τ_{theo}	$\tau_{(theo)_{exp}}$
0	54.66	12	60	27.12	25.84	0.74	21.30	0.79	21.85	0.81	18.48	0.68	19.26	0.71
	54.66	12	167	11.44	16.23	1.20	17.37	1.45	21.85	1.85	5.45	0.5	19.26	1.61
	54.66	20	100	18.98	21.51	0.83	15.16	0.8	17.48	0.93	18.4	0.98	12.73	0.67
25	54.11	12	60	27.05	25.79	0.74	21.51	0.79	21.75	0.81	18.3	0.68	19.16	0.71
	54.11	12	167	11.39	16.18	1.23	21.47	1.51	21.75	1.90	5.45	0.56	19.16	1.67
	54.11	20	100	18.55	21.47	0.85	15.08	0.82	17.48	0.94	18.3	0.99	12.73	0.69
50	50.33	12	60	26.53	25.39	0.73	20.41	0.77	20.94	0.79	17.7	0.67	18.46	0.70
	50.33	12	167	10.83	15.78	1.28	16.64	1.51	20.94	1.93	5.4	0.53	18.46	1.68
	50.33	20	100	17.51	21.23	0.86	15.33	0.83	16.75	0.96	17.7	1.01	12.2	0.70
100	47.08	12	60	25.87	25.09	0.73	19.83	0.77	20.34	0.79	17.2	0.67	17.92	0.70
	47.08	12	167	10.26	15.48	1.28	16.17	1.55	20.34	1.96	5.34	0.53	17.92	1.72
	47.08	20	100	15.63	21.05	0.94	14.11	0.91	16.27	1.03	17.2	1.10	11.85	0.76
Mean						0.951		1.041		1.22		0.74		1.02
S.D						0.228		0.34		0.51		0.21		0.47
C.O.V						0.24		0.33		0.41		0.29		0.46

2
3
4 **4.2. Degradation of Bond strength due to corrosion**

5
6
7 The relationship between corrosion rate and its effect on the performance of bond has been investigated
8 by several researchers. Most of the existing models expressed the change in the bond strength due to
9 corrosion as follow:

10
$$K_t = \frac{\tau_c}{\tau_0}$$

11 where K_t is the relative bond strength, τ_0 is the maximum bond strength without corrosion, and τ_c is the
12 maximum bond strength with corrosion.
13

14 The existing models for K_t are listed in Table 6, and compared to the experimental results in Fig .18. It
15 can be noted that the relative bond strengths predicted by the existing models exhibit conservative
16 results compared to those obtained from the experimental work. In particular, the relative bond strengths
17 predicted by Lee et al., (2002) and Kivell et al. (2012) are highly overestimated. This could be associated
18 to the inaccuracy of these models as they were designed based on the results obtained from different
19 experimental works, having different testing procedures, corrosion current and materials strength. For
20 example, the compressive strengths in the current study are much higher than that used in these
21 models. Apart from Auyeung et al., (2000) model, which exhibits the best performance with $R^2= 0.80$,

1 the bond strengths obtained from all other models are overestimated, since they tend to monotonically
2 decrease with the increase of corrosion rate. The empirical equations suggested by [70] Carbera, (1996)
3 and [71] Bhargava et al., (2007) showed that the bond linearly declined by increasing the corrosion rate,
4 which does not properly match the actual degradation trend. On the other hand, the formula proposed
5 by Chung et al., (2008) overestimated the experimental bond strengths for both normal and recycled
6 aggregate concretes. It is also noted that during the stage of increase in bond strength due to corrosion,
7 all the values were expressed by (1), making the bond strengths before and after exposure to corrosion
8 are the same, which were differently observed by the experimental results. From the experimental
9 results, it can be said that the relationship between K_t and corrosion rate (η) slightly increases with a
10 small amount of corrosion, and afterwards significantly decreases. This trend has not been captured by
11 any of these models.

12
13 Table 7. Degradation model of relative bond strength by previous researchers.

References	Normalised equation	K_t ($\frac{expminal}{predicted}$)
Cabrera (1996)	$K_t = 1 - 5.6 \eta$,	0.72
Auyeung et al. (2000)	$K_t = e^{-32.51 \eta}$	0.80
Lee et al. (2002)	$\text{If } f'_c \leq 21 \text{ MPa, } K_t = 1, \text{ for } \eta < \frac{\ln((0.34f'_c - 1.93)/5.21)}{-0.0561} \%$ $K_t = \frac{5.21e^{-0.0561\eta}}{0.34f'_c - 1.93} \text{ for } \eta > \frac{\ln((0.34f'_c - 1.93)/5.21)}{-0.0561} \%$ $\text{If } f'_c > 21 \text{ MPa, } K_t = \frac{5.21e^{-0.0561\eta}}{5.21}$	0.57
Chung et al., (2008)	$K_t = 1 \text{ for } \eta \leq 2.0\%$ $K_t = \frac{24.7\eta^{-0.55}}{16.87} \text{ for } \eta > 2.0\%$	0.64
Bhargava et al., (2007)	$K_t = 1.192 \eta^{(-0.117 \eta)}, \eta > 1.5\%$ $K_t = 1.0 \text{ for } \eta \leq 1.5\%$	0.68
Kivell (2012)	$K_t = e^{-7.61 (\eta - 2.4\%)}, \eta \leq 1.0$ $K_t = 1.2 e^{-0.076 \eta}, \eta > 1.0$	0.57

14

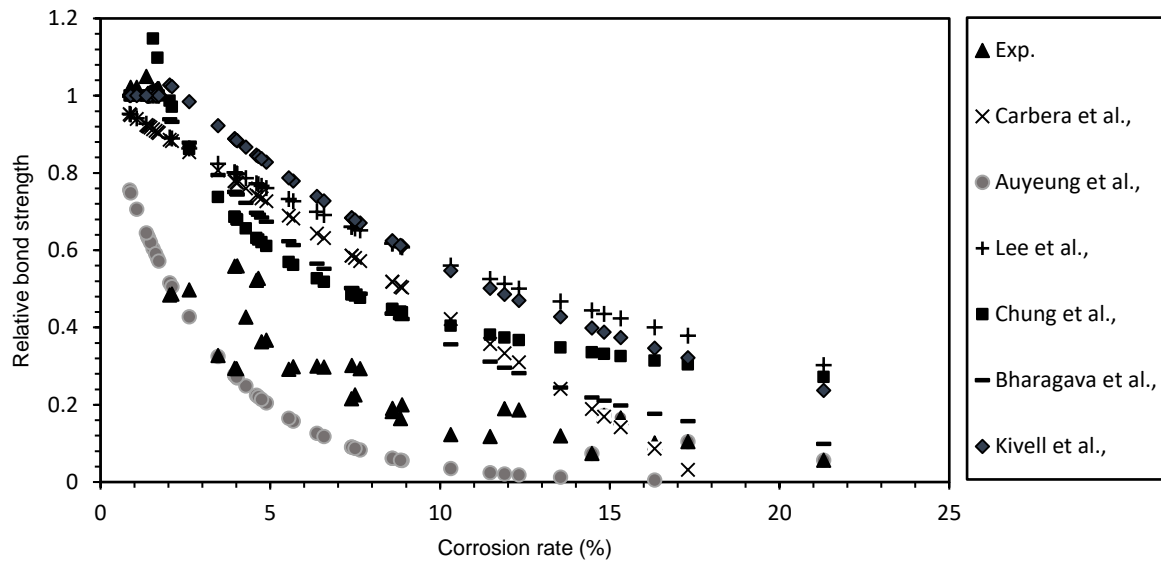

Fig. 19. Comparison of bond strength reduction models to experimental results.

5. Conclusions

Experimental investigations were performed to evaluate the influence of recycled coarse aggregate on concrete properties and bond of reinforcing bars embedded in recycled coarse aggregate concrete under different levels of corrosion. Based on the results obtained from this investigation, the following conclusions can be drawn:

- The compressive strength of RCA concrete gradually reduces by increasing the amount of RCA in concrete. At 100% of RCA replacement rate, the compressive strength reduces by approximately 15% at 28 days; however, this effect becomes less pronounced as time of curing extended to 90 days.
- The tensile strength and flexural strength of RCA concrete are not significantly influenced by the replacement level of RCA; an 8% tensile/flexural strength reduction was observed at 100% RCA replacement. However, the water absorption of RCA concrete was considerably affected by the RCA content, reflecting the higher water absorption capacity of recycled aggregate.
- Overall, concrete with 25% RCA replacement level is comparable to normal concrete and did not show a significant change, even in harsh environmental conditions, and therefore, RCA can be recommended to be used up to this limit in structural applications.
- Corrosion of reinforcing steel initiated faster in RCA concrete than NCA, and larger corrosion rate was reported with the increase of the replacement level of RCA due to its high porosity and water absorption.

- 1 - The ultimate bond strength of un-corroded steel concrete specimens is slightly affected by the
2 increase of RCA level, but larger steel bar diameters may exhibit more bond strength reduction.
3 Furthermore, the difference of bond strength between NCA and RCA concrete becomes more
4 pronounced as the corrosion rate increases.
- 5 - The bond strength of RCA concrete was strongly affected by corrosion products; bond strength
6 slightly enhanced by up to 2% corrosion rate, however, this enhancement reported higher with
7 the increase of RCA level. As the corrosion time further increased, the bond strength is
8 significantly decreased, similar to that of conventional concrete. However, the rate of bond
9 degradation between RCA concrete and corroded steel is much faster than that found in
10 corroded conventional concrete.
- 11 - No significant differences between NCA and RCA concrete were observed in terms of bond
12 stress-slip curves and failure mode before and after exposure to corrosion.
- 13 - For the same surface area, steel bars having larger diameter showed better bond strength for
14 both NCA and RCA owing to the influence of surface ribs characteristics of steel bars. However,
15 as the corrosion rate increased, this influence has reduced.

16 **6. Acknowledgments**

17 The authors wish to thank MONE BROS Company in Leeds (UK) for providing recycled aggregates
18 used in this study. The authors also gratefully acknowledge Hanson Ltd, UK for supplying cement used
19 in this study.

20 **7. References**

- 21 [1]. Silva, R. V., et al. Establishing a relationship between modulus of elasticity and compressive
22 strength of recycled aggregate concrete. *Journal of Cleaner Production* 2016; 112: 2171-2186.
- 23 [2]. De Brito, J. and N. Saikia. *Recycled aggregate in concrete: use of industrial, construction and
24 demolition waste*, Springer Science & Business Media 2012.
- 25 [3]. Behera, M., et al. Recycled aggregate from C&D waste & its use in concrete—A breakthrough
26 towards sustainability in construction sector: A review. *Construction and building materials* 2014; 68:
27 501-516.
- 28 [4]. Poon, C., et al. Influence of moisture states of natural and recycled aggregates on the slump and
29 compressive strength of concrete. *Cement and Concrete* 2004.
- 30 [5]. Prince, M. J. R. and B. Singh. Bond behaviour of deformed steel bars embedded in recycled
31 aggregate concrete. *Construction and building materials* 2013; 49: 852-862.
- 32 [6]. Casuccio, M., et al. Failure mechanism of recycled aggregate concrete. *Construction and building
33 materials* 2008; 22(7): 1500-1506.

- 1 [7]. Padmini, A., et al. Influence of parent concrete on the properties of recycled aggregate concrete.
2 Construction and building materials 2009; 23(2): 829-836.
- 3 [8]. Tabsh, S. W. and A. S. Abdelfatah. Influence of recycled concrete aggregates on strength
4 properties of concrete. Construction and building materials_2009; 23(2): 1163-1167.
- 5 [9]. ACI Committee 408. Bond development of straight reinforcing bars in tension (ACI 408R-03).
6 American Concrete Institute, Farmington Hills, USA 2003.
- 7 [10]. Auyeung, Y., et al. Influence of Corrosion on Bond Behavior of Reinforcement Bars. Special
8 Publication 2000; 193: 1051-1074.
- 9 [11]. Fang, C., et al. Corrosion influence on bond in reinforced concrete. Cement and Concrete
10 Research 2004; 34(11): 2159-2167.
- 11 [12]. Coccia, S., et al. Influence of corrosion on the bond strength of steel rebars in concrete. Materials
12 and structures_2016; 49(1-2): 537-551.
- 13 [13]. Sonebi, M., et al. Bond between Reinforcement and Concrete–Influence of Steel Corrosion.
14 International conference on durability of building materials and components, Porto–Portugal 2011.
- 15 [14]. Vidal, T., et al. Analyzing crack width to predict corrosion in reinforced concrete. Cement and
16 Concrete Research 2004; 34(1): 165-174.
- 17 [15]. Rao, A., et al. Use of aggregates from recycled construction and demolition waste in concrete.
18 Resources, conservation and Recycling 2007; 50(1): 71-81.
- 19 [16]. Ajdukiewicz, A. and A. Kliszczewicz. Influence of recycled aggregates on mechanical properties of
20 HS/HPC. Cement and Concrete Composites 2002; 24(2): 269-279.
- 21 [17]. Xiao, J. and H. Falkner. Bond behaviour between recycled aggregate concrete and steel rebars.
22 Construction and building materials 2007; 21(2): 395-401.
- 23 [18]. Kim, S.-W. and H.-D. Yun. Influence of recycled coarse aggregates on the bond behavior of
24 deformed bars in concrete. Engineering Structures 2013; 48: 133-143.
- 25 [19]. BS 882: Specification for aggregates from natural sources for concrete, British Standards Institute
26 1992.
- 27 [20]. BS 4449: Steel for the reinforcement of concrete. Weldable reinforcing steel. Bar, coil and
28 decoiled product. Specification, British Standards Institute 2005.
- 29 [21]. RILEM/CEB/FIP. Recommendations on reinforcement steel for reinforced concrete 1983. RC 6,
30 CEB News 73.
- 31 [22]. Yuan, Y., et al. Comparison of two accelerated corrosion techniques for concrete structures. ACI
32 Structural Journal 2007; 104(3): 344.
- 33 [23]. Austin, S. A., et al. Electrochemical behavior of steel-reinforced concrete during accelerated
34 corrosion testing. Corrosion 2004; 60(2): 203-212.
- 35 [24]. Caré, S. and A. Raharinaivo. Influence of impressed current on the initiation of damage in
36 reinforced mortar due to corrosion of embedded steel. Cement and Concrete Research 2007; 37(12):
37 1598-1612.
- 38 [25]. Azad, A. K., et al. Residual strength of corrosion-damaged reinforced concrete beams. ACI
39 Materials Journal 2007; 104(1): 40.

- 1 [26]. Cairns, J. and G. Plizzari. Towards a harmonised European bond test. *Materials and structures*
2 2003; 36(8): 498.
- 3 [27]. BS EN 12350-2: Testing fresh concrete. Slump-test, British Standards Institute 2009.
- 4 [28]. BS EN 12390-3: Testing hardened concrete. Compressive strength of test specimens, British
5 Standards Institute 2009.
- 6 [29]. BS EN 12390-6: Testing hardened concrete, Part 6: tensile splitting strength of test specimens.
7 British Standards Institution_2009.
- 8 [30]. BS EN 12390-5. Testing hardened concrete—Part 5: flexural strength of test specimens. British
9 Standards Institution-BSI and CEN European Committee for Standardization_2009.
- 10 [31]. BS 1881-206:1986: Testing concrete. Recommendations for determination of strain in concrete,
11 British Standards Institute.
- 12 [32]. BS EN 12390-7: Testing hardened concrete. Density of hardened concrete, British Standards
13 Institute 2009.
- 14 [33]. Metals, A. C. G.-o. C. o. Standard practice for preparing, cleaning, and evaluating corrosion test
15 specimens, ASTM international 2011.
- 16 [34]. Rao, M. C., et al. Influence of field recycled coarse aggregate on properties of concrete. *Materials*
17 *and structures* 2011; 44(1): 205-220.
- 18 [35]. Xiao, J., et al. An overview of study on recycled aggregate concrete in China (1996–2011).
19 *Construction and building materials* 2012; 31: 364-383.
- 20 [36]. Butler, L., et al. The effect of recycled concrete aggregate properties on the bond strength
21 between RCA concrete and steel reinforcement. *Cement and Concrete Research* 2011; 41(10): 1037-
22 1049.
- 23 [37]. Etxeberria, M., et al. Influence of amount of recycled coarse aggregates and production process
24 on properties of recycled aggregate concrete. *Cement and Concrete Research* 2007; 37(5): 735-742.
25
- 26 [38]. McNeil, K. and T. H.-K. Kang. Recycled concrete aggregates: A review. *International Journal of*
27 *Concrete Structures and Materials* 2013; 7(1): 61-69.
- 28 [39]. Evangelista, L. and J. De Brito. Mechanical behaviour of concrete made with fine recycled
29 concrete aggregates." *Cement and Concrete Composites* 2007; 29(5): 397-401.
- 30 [40]. Kurad, R., et al. Effect of incorporation of high volume of recycled concrete aggregates and fly
31 ash on the strength and global warming potential of concrete. *Journal of Cleaner Production* 2017;
32 166: 485-502.
- 33 [41]. Yang, K.-H., et al. Influence of Type and Replacement Level of Recycled Aggregates on Concrete
34 Properties 2008.
- 35 [42]. Kou, S.-c. and C. Poon. Enhancing the durability properties of concrete prepared with coarse
36 recycled aggregate. *Construction and building materials* 2012; 35: 69-76.
- 37 [43]. Zhao, Z., et al. Influence of fine recycled concrete aggregates on the properties of mortars."
38 *Construction and building materials* 2015; 81: 179-186.
- 39 [44]. Fernández Pérez, I., et al. Ultimate bond strength assessment of uncorroded and corroded
40 reinforced recycled aggregate concretes. *Construction & building materials* 2016; 111: 543-555.
41

- 1 [45]. Yang, H., et al. A study on the bond behavior of corroded reinforced concrete containing recycled
2 aggregates. *Advances in Materials Science and Engineering* 2015.
- 3 [46]. Kim, Y., et al. Mechanical properties of recycled aggregate concrete with deformed steel re-bar.
4 *Journal of marine science and technology* 2012; 20(3): 274-280.
- 5 [47]. Prince, M. J. R. and B. Singh. Bond behaviour of deformed steel bars embedded in recycled
6 aggregate concrete. *Construction and building materials* 2013; 49: 852-862.
- 7 [48]. Zhao, Y., et al. Bond behaviour of normal/recycled concrete and corroded steel bars.
8 *Construction and building materials* 2013; 48: 348-359.
- 9 [49]. Ouglova, A., et al. The influence of corrosion on bond properties between concrete and
10 reinforcement in concrete structures. *Materials and structures* 2008; 41(5): 969-980.
- 11 [50]. Almusallam, A. A. Effect of degree of corrosion on the properties of reinforcing steel bars.
12 *Construction and building materials* 2001; 15(8): 361-368.
- 13 [51]. Chung, L., et al. Bond strength prediction for reinforced concrete members with highly corroded
14 reinforcing bars." *Cement and Concrete Composites* 2008; 30(7): 603-611.
- 15 [52]. Metelli, G. and G. A. Plizzari Influence of the relative rib area on bond behaviour. *Magazine of*
16 *Concrete Research* 2014; 66(6): 277-294.
- 17 [53]. Darwin, D. and E. K. Graham. Effect of deformation height and spacing on bond strength of
18 reinforcing bars, University of Kansas Center for Research, Inc 1993.
- 19 [54]. CEB-FIP Model Code, Comite' Euro-International du Be' ton, 2010.
- 20 [55]. Orangun, C., et al. The strength of anchored bars: a reevaluation of test data on development
21 length and splices, Center for Highway Research, University of Texas at Austin 1975.
- 22 [56]. Zuo, J. and D. Darwin. Bond strength of high relative rib area reinforcing bars, University of Kansas
23 Center for Research, Inc 1998.
- 24 [57]. Zuo, J. and D. Darwin. Splice strength of conventional and high relative rib area bars in normal
25 and high-strength concrete, American Concrete Institute 2000.
- 26 [58]. Pour, S. M. and M. S. Alam. Investigation of compressive bond behavior of steel rebar
27 embedded in concrete with partial recycled aggregate replacement. *Structures*, Elsevier 2016.
- 28 [59]. Shang, H.-s., et al. Bond behavior of steel bar embedded in recycled coarse aggregate concrete
29 under lateral compression load. *Construction and building materials* 2017;150: 529-537.
- 30 [60]. Ichinose, T., et al. Size effect on bond strength of deformed bars. *Construction and building*
31 *materials* 2004; 18(7): 549-558.
- 32 [61]. Pour, S. M. and M. S. Alam. Investigation of compressive bond behavior of steel rebar embedded
33 in concrete with partial recycled aggregate replacement. *Structures*, Elsevier 2016.
- 34 [62]. Wassouf, M. Bond and ductility of concrete reinforced with various steel bars surface and
35 ductility conditions, University of Birmingham 2015.
- 36 [63]. Tepfers, R. and T. G. B. M. I. F. f. S. Concrete. Bond of reinforcement in concrete: state-of-art
37 report, Internat. Fed. for Structural Concrete 2000.
- 38 [64]. Andrade, C. and C. Alonso. On-site measurements of corrosion rate of reinforcements.
39 *Construction and building materials* 2001; 15(2-3): 141-145.

- 1 [65]. Darwin, D., et al. Development length criteria: bars not confined by transverse reinforcement,
2 American Concrete Institute 1992.
- 3 [66]. Esfahani, M. R. and B. V. Rangan. Bond between normal strength and high-strength concrete
4 (HSC) and reinforcing bars in splices in beams. *Structural Journal* 1998; 95(3): 272-280.
- 5 [67]. Australian Standard, A. 3600. Concrete Structures, Standards Australia, Sydney 2004.
- 6 [68]. Lee, H.-S., et al. Evaluation of the bond properties between concrete and reinforcement as a
7 function of the degree of reinforcement corrosion. *Cement and Concrete Research* 2002; 32(8): 1313-
8 1318.
- 9 [69]. Kivell, A., et al. Corrosion related bond deterioration and seismic resistance of reinforced
10 concrete structures. *Structures Congress* 2012.
- 11 [70]. Cabrera, J. Deterioration of concrete due to reinforcement steel corrosion. *Cement and Concrete*
12 *Composites* 1996; 18(1): 47-59.
- 13 [71]. Chung, L., et al. Bond strength prediction for reinforced concrete members with highly corroded
14 reinforcing bars. *Cement and Concrete Composites* 2008; 30(7): 603-611.
- 15 [72]. Bhargava, K., et al. Corrosion-induced bond strength degradation in reinforced concrete—
16 Analytical and empirical models. *Nuclear Engineering and Design* 2007; 237(11): 1140-1157.