

# bradscholars

## Designing composite structures for reuse

Item Type	Conference paper
Authors	Lam, Dennis;Yang, Jie;Dai, Xianghe;Sheehan, Therese;Zhou, Kan
Citation	Lam D, Yang J, Dai X et al (2018) Designing composite structures for reuse. In: Proceedings of the 9th International Conference on Advances in Steel Structures, ICASS. 5-7 Dec 2018. Hong Kong, China.
Rights	© 2018 Hong Kong Institute of Steel Construction. Full-text reproduced with publisher permission.
Download date	2026-03-09 00:29:03
Link to Item	<a href="http://hdl.handle.net/10454/18211">http://hdl.handle.net/10454/18211</a>

## DESIGNING COMPOSITE STRUCTURES FOR REUSE

Dennis Lam<sup>1\*</sup>, Jie Yang<sup>1</sup>, Xianghe Dai<sup>1</sup>, Therese Sheehan<sup>1</sup> and Kan Zhou<sup>1</sup>

<sup>1</sup> School of Engineering, Faculty of Engineering and Informatics, University of Bradford, Bradford, UK  
E-mails: D.Lam1@bradford.ac.uk, J.Yang17@bradford.ac.uk, X.Dai@bradford.ac.uk,  
T.Sheehan@bradford.ac.uk, K.Zhou1@bradford.ac.uk

---

**Abstract:** *Steel is a highly versatile and 100% recyclable material but is also carbon and energy intensive in production. Steel framed structures are inherently adaptable and potentially demountable. Reuse instead of the common practice of recycling steel by melting, makes good environmental sense, saving both on resources and carbon emissions. Reuse is commercially and technically viable, as demonstrated by isolated projects. Although steel reuse has been identified as an effective method to reduce the carbon and energy impact of construction, it is in effect only marginally used in practice. We found that although there is a sufficient spread between the price of steel scrap and new steel, this difference cannot be captured by the demolition contractors. In steel multi-storey high-rise building structures, composite construction is the most efficient and economic forms of construction. Composite beams incorporate composite floors with profiled steel sheeting are the most common structural system used in multi-storey high-rise buildings and is seen as one of the most important ways of expanding the use of steel buildings in Europe, i.e. increasing market share. However, in terms of reuse, current composite construction systems require extensive cutting on-site during the demolition process making reuse not viable. This paper presents an innovative composite system that is designed for deconstruction and reuse, its structural behaviour and failure modes were observed and analysed through a series of experimental studies and numerical simulation. The results showed that the structural behaviour of this new form of composite system not only allows for deconstruction and reuse, it has a similar structural performance to the traditional composite system with welded shear connectors.*

**Keywords:** Steel, Composite structures, Reuse, Recycle, Deconstruction, Shear Connectors

**DOI:** 10.18057/ICASS2018.xxx

---

### 1 INTRODUCTION

In the recent years, our city has become fragile as its infrastructures and built environment no longer satisfied the need of its residents. Environmental related issues such as sustainability, energy saving, recycling and material reuse have been in the forefront of our industry, trying to improve the current building environment and enable that our future generations have enough resources to fulfil their needs. The construction industry is heavily relying on the natural resources such as sands, stones, iron and coal, etc. which are slowly running out. Perhaps these materials will not be running out in our lifetime, but political influence could sometimes change these with little notices.

Steel-concrete composite structures have been used in the construction industry since the early 1920s and reckoned to be one of the most efficient and cost-effective construction systems for multi-storey buildings and bridges owing to the composite action between steel beams and concrete slabs. However, the use of welded shear connectors to achieve the composite action between the steel beam and the composite concrete slab made dismantling, alteration and deconstruction almost impossible. This means that these structural components, such as steel beams and composite concrete slabs cannot be easily demounted and reuse. Although the steel beams might subsequently be recycled, the recycling process consumes massive energy and generates a large volume of CO<sub>2</sub> emission, which is not the best option from the points of the sustainable construction. In recent years, more sustainable building techniques are being considered and recommended in the construction industry to reduce waste and reuse materials more efficiently without recycling. Recently, researchers have been searching for innovative connection systems to overcome the weakness of the welded shear connectors to make the deconstruction of the composite system possible, bolts used as demountable shear connectors might be a solution, however, so far bolts have not been extensively adopted in construction practice to fulfil the deconstruction aim. Although research on the use of high strength bolts as shear connectors started by Dallam [1] in the 1960s, Marshall *et al.* [2] in the 1970s, Dedic & Klaiber [3] and Hawkins [4] in the 1980s, all these researches were mainly focussed on retrofitting rather than demountability, more research is needed on the behaviour of demountable shear connectors in composite structures. In the above-mentioned research work, high strength friction grip bolts in solid concrete slabs were investigated by carried out the push tests and full-scale composite beam tests. These bolts were installed using a post-installation method rather than casting in the concrete slab, which meant a large tolerance for the placement of these connectors is required. In recent years, bolted shear connectors were studied. Atei *et al.* [5] investigated the behaviour of high strength friction grip bolts in geo-polymer concrete slabs and normal concrete slabs through push tests and full-scale composite beam tests. Lee and Bradford [6] conducted push tests using M20 Gr8.8 bolted shear connectors with a single embedded nut while Ataei and Bradford [7] tested pre-tensioned bolts with precast solid concrete slabs for a demountable connection system. Pavlovic *et al.* [8] studied the M16 Gr8.8 bolted shear connector through push tests in solid slabs and compared the experimental results with welded headed shear studs in solid slabs. It was found that the Gr8.8 bolted shear connectors with a single embedded nut achieved about 95% of the shear resistance under static loads, but the stiffness was reduced by 50% compared to the welded headed stud. A full-scale composite beam test with profiled metal decking was reported by Moynihan and Allowed [9] using M20 Gr 8.8 bolts as shear connectors in a composite beam. The research showed that these bolts may be used as demountable connectors and they behaved in a similar way to welded connectors and the slabs can be taken off easily from the steel beam. Lam and Saveri [10] and Dai *et al.* [11] investigated the load slip behaviour of modified demountable shear connectors through push tests and finite element modelling. Rehman *et al.* [12-13] studied the modified demountable shear connectors in composite slabs by push tests and full-scale composite beam systems. It was found that the demountable shear connectors completely fulfilled the aim of deconstruction of the composite system.

Although more research had been carried out in recent years on this form of bolted connectors, the majority were focussed on precast construction and solid slabs, which are not the most common and efficient way to construct composite structures for multi-storey buildings. This paper presents recent research by the authors on the use of demountable bolted shear connectors using cast in-situ composite construction with profiled decking, the aim is trying to keep the first cycle of use as close as possible to the current construction practices.

The behaviour and failure modes were analysed through a series of push tests and numerical simulations, which led to a better understanding to the behaviour of this form of shear connectors.

## 2 EXPERIMENTAL STUDY

To assess the shear resistance, stiffness and ductility of the demountable bolted shear connectors, standard push tests were conducted in the Heavy Structures Laboratory at the University of Bradford. Parameters considered were embedment height of the shear bolted connector, type of bolted shear connectors, reinforcement cage and ease of demountability. Test set up, instrumentation and testing procedures are presented in the following sub-sections.

### 2.1 Test arrangement

Standard push test arrangement in accordance to Eurocode 4 [14] was used, Figure 1 shows the push test setup. The dimensions of the continuous slab are 900 mm long  $\times$  610 mm wide with a maximum slab thickness of 150 mm. For the discontinuous slab, two separate slabs cover the continuous slab dimension with a 2 mm gap between the slabs. 2 rows of shear connectors (8No. of shear connectors) were used as recommended by the Eurocode 4, a 254  $\times$  254 UC 73 was used to connect the slabs to form the push test specimens. A 100-tonne actuator was used to apply the compressive load on the specimens. A loading plate was placed on the top end of the beam section. Four of the eight LVDTs adopted were put on each corner of this plate to measure the movement of the beam during the experiments. The other four LVDTs were placed on the profiled slabs with two on each slab, to measure the displacement of the slabs. The relative slip between the slabs and the beam section was obtained as the mean difference of this two set of LVDTs measurements. In addition, eight strain gauges were attached to the beam flange near the upper side of the bolt hole to monitor the load distribution among the shear connectors during tests. Figures 2 and 3 show the positions of the LVDTs and the strain gauge.

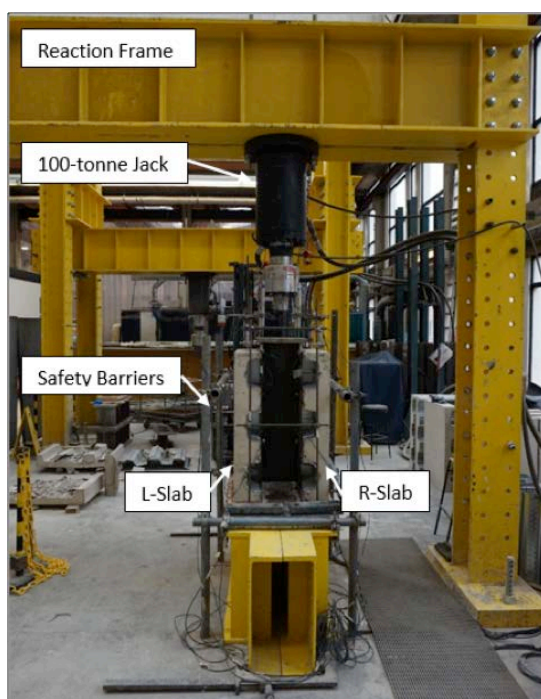

Figure 1: Test set-up

Eurocode 4 test regime was used for the push tests. Firstly, 25 loading cycles were applied between 5% and 40% of the maximum load obtained from the first tested specimen, then the load was increased towards the maximum load. Once the maximum load was reached, this was followed by a 5 minute waiting period before further increasing the displacement. When the load dropped down to 95% of the maximum load, this was followed by a second 5 minutes waiting period before using displacement control with a rate of 0.5mm/min until the specimen failure occurred.



Figure 2: Positions of LVDTs



Figure 3: Position of the strain gauge directly above the bolt hole

## 2.2 Test results

A series of push test specimens with various parameters were tested. The following subsections compare the important parameters.

### 2.2.1 Embedment height of the shear connectors

The embedment heights of the bolted shear connectors in the profiled slabs were examined. The considered heights of the bolted shear connectors were 100 mm and 120 mm respectively. Load vs. slip curves are given in Figure 4. For the specimen with 100mm

connectors, brittle concrete failure was observed when the maximum load of 34 kN and 2.7 mm slip was reached. The load at 6 mm slip was only 21.3 kN, which was only 62.6% of the maximum load, therefore, it did not meet the 6 mm ductility requirement specified in the Eurocode 4. For the specimen with 120 mm connectors, a maximum load of 55.0 kN was recorded at 6 mm slip, which is 58.2% higher than that of the 100mm counterpart. A maximum load of 56.2 kN was obtained at the slip of 7.3 mm. This showed that the embedment height of the shear connectors in profiled slabs has a huge influence on the shear resistance of the bolted connector. Figure 5 shown the failure of the 100 mm bolted shear connectors.

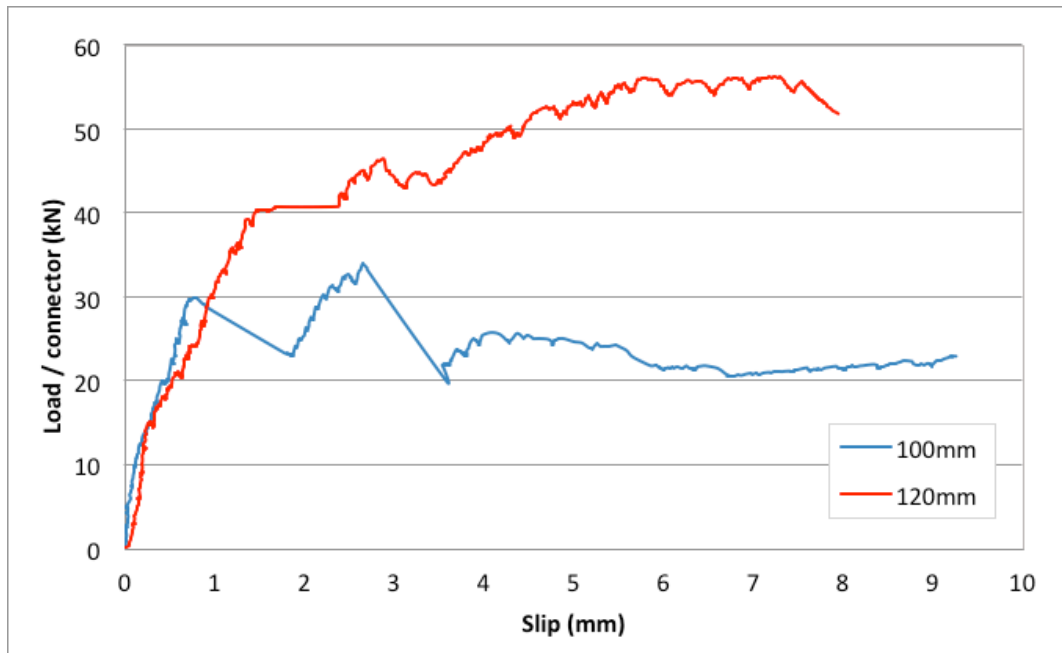

Figure 4: Load vs. slip curves of 100mm vs. 120mm bolted connector



Figure 5: Failure mode of the push test with 100mm bolted connectors

### 2.2.2 Types of bolted connectors

Two types of bolted shear connectors in the profiled slabs were examined, namely the M20 Gr 8.8 bolts and the 20mm demountable shear connectors manufactured from standard TW Nelson 22mm studs. Both sets of specimens were identical in terms of concrete strength (C30/37), connector height (120mm) and deck profiled. The average Load vs. slip curves for these two sets of push tests are given in Figure 6. For the specimen with M20 bolts, maximum load of 62 kN was reached at slip of 10 mm. The load at 6 mm slip was around 60 kN. For the specimen with 22 /20 mm demountable connectors, a maximum load of 63 kN was achieved at 6 mm slip. This showed bolt types of connectors achieved the similar result although the failure mode of both sets of specimens was concrete failure, therefore the strength of the connector would not make a significant effect to the shear resistance.

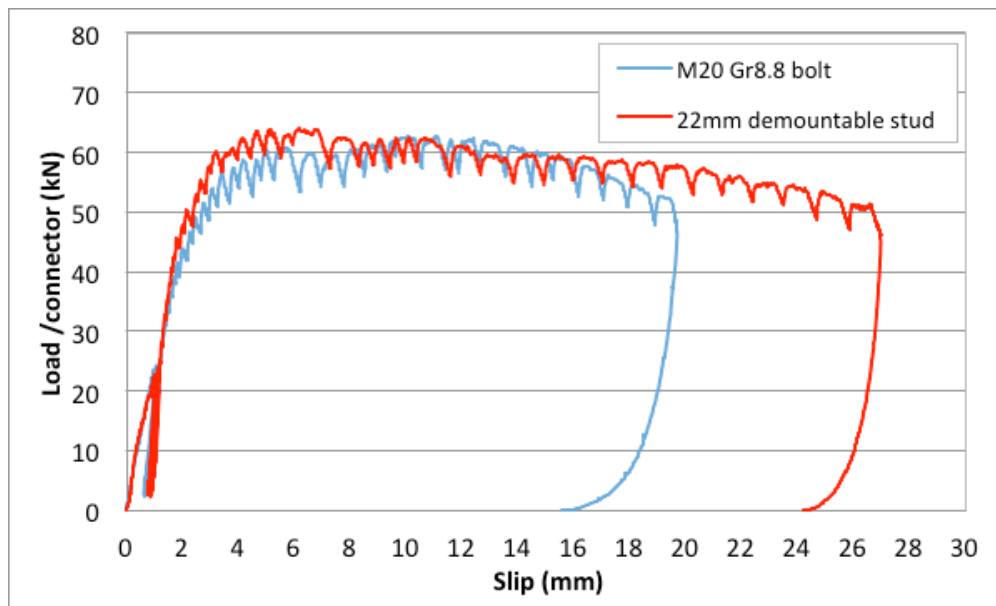

Figure 6: M20 bolt vs. 22mm demountable stud

### 2.2.3 Reinforcing cage for the profiled slabs

To investigate the effect of the reinforcement, two different types of reinforcing cages were used. Once again, both sets of specimens were identical in terms of concrete strength (C25/30), connector height (120mm) and deck profiled with the only different being the design of the reinforcing cages. The design of the cages is shown in Figure 7.

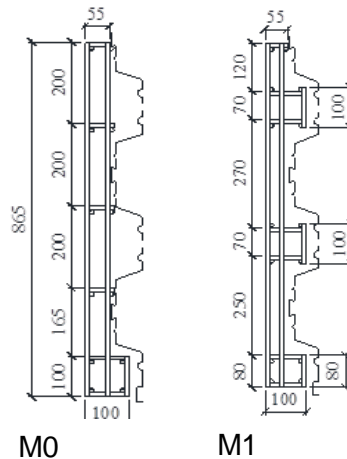

Figure 7: Design of the reinforcing cage

The average load vs. slip curves for these two sets of push tests are given in Figure 8. The experimental results show that the specimens with the modified reinforcing cage (M1) have higher connector resistance than those specimens with the double layers of reinforcement (M0). The connector resistance was about 10% higher than the specimens with the M0 reinforcing cage. However, the slip ductility was significantly increased. Therefore, increase in reinforcement ratio especially with extra confinement around the shear connectors would improve the slip ductility of the shear connector as it provided better confinement to the concrete.

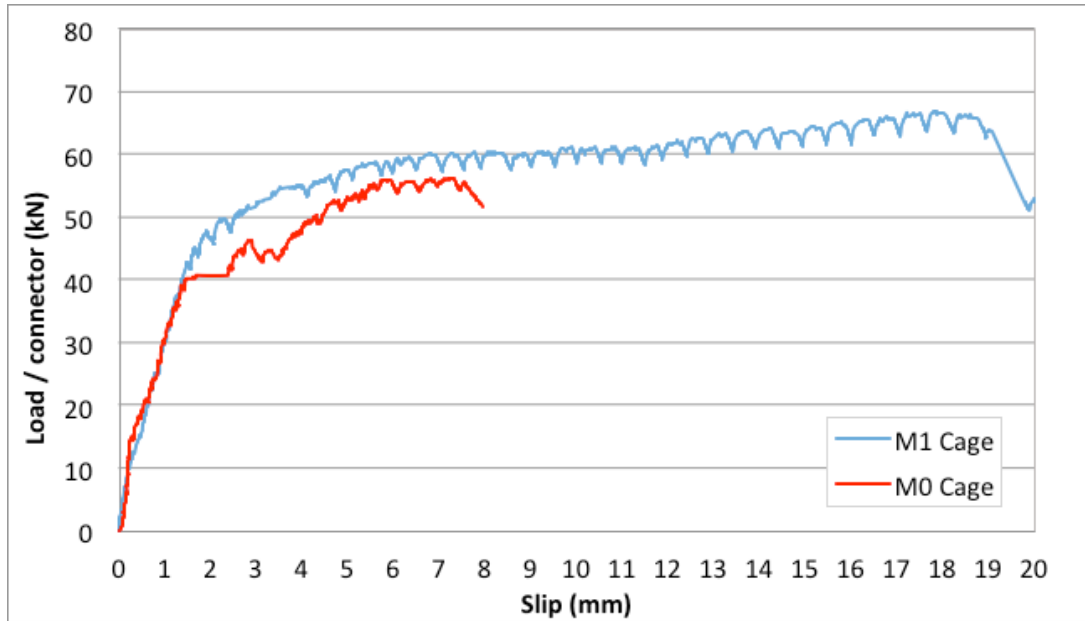

Figure 8: Effect of profiled slabs reinforcement

#### 2.2.4 Ease of demountability

To investigate the ease of demountability, edge trims were placed in the centre of the profile slabs. The purpose of the edge trim is purely for the ease of deconstruction so that the slabs can be separated and removed easily after the connectors are undone. Two arrangements have been considered, a full depth edge trim of 150mm and a partial edge trim of 130mm as shown in Figure 9.



(a) Full depth edge trim



(b) Partial depth edge trim

Figure 9: Edge trim arrangement

For the full depth edge trim specimens, the A193 mesh was discontinuous and no cutting would be required for deconstruction, on the other hand, for the partial depth edge trim specimens, a 20 mm cut along the centre-line is required before the slabs can be separated and remove. Figure 10 shows the load vs. slip curves of these two sets of push test. Specimens with the full depth edge trim had a lower initial stiffness probably due to the 2 mm gap between the slabs, however the slip ductility is much better than the specimens with a partial depth edge trim. At 6mm slip, the connector from the specimens with partial edge trim had a resistance of 71 kN as compared to 65 kN for the specimen with full depth edge trim. Although specimen with partial edge trim had higher connector resistance, a 20mm cut along the centre line of the beam will be required during deconstruction. Figure 11 shows the specimens with full depth edge trim dismantled after the test.

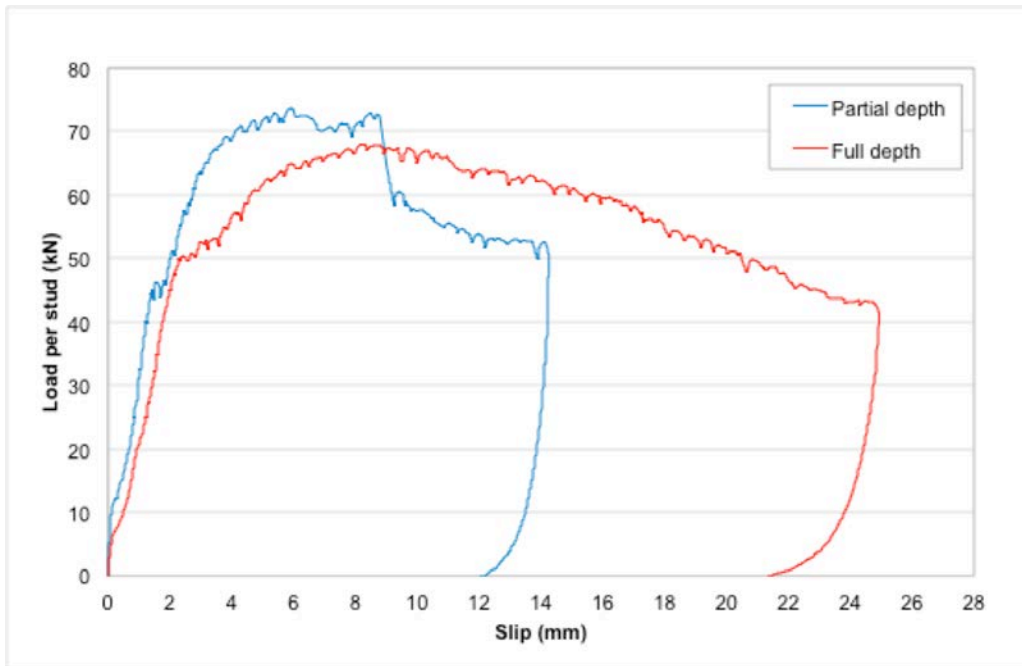

Figure 10: Effect of the edge trim



Figure 11: Push test specimen with full depth edge trim

### 3 FINITE ELEMENT ANALYSIS

#### 3.1 Finite element model

The nonlinear finite element software ABAQUS [15] was used to develop the FE model for the push test specimens. Considering the symmetrical condition of the test specimens across the centre line of the beam web, only half of the specimen was modelled to achieve computational efficiency. Three dimensional eight-node solid brick elements with reduced integration (C3D8R) were adopted to model the concrete slab, steel beam, bolt and nut. Two-node truss elements (T3D2) were used for the reinforcement cage and U-bars. Since both the profiled metal decking and the profiled metal edge trim are thin, shell elements with reduced integration (S4R) were used. Contact pairs with appropriate behaviour were defined between interacting surfaces of different components. For interaction between concrete slabs and profiled metal decking, “hard” contact condition was used for normal contact behaviour and the “penalty” contact condition with a coefficient of friction of 0.3 was adopted for tangential behaviour. For contact between metal decking and the steel beam and between bolts/nuts and the steel beam, “hard” contact was used for normal contact and “penalty” with a friction coefficient of 0.2 were used for tangential behaviour. The relationship/contact between bolts and concrete slabs is different. In view of the fact that the bolt threads were teathed together with the concrete, the tangential behaviour “rough” was used to restrain the slip. The normal interaction was still defined as “hard” contact. This behaviour was compared with tying (tie) the bolt shaft to the concrete, and similar results were obtained. Since the edge trim was partially inserted into the concrete, the slip between the slab and edge trim profile was limited. Therefore, in the model, the edge trim outside the concrete slab was “tied” to the concrete, while the edge trim inside the concrete slab was “embedded” in the concrete. Both reinforcement mesh/cage and U-bar were “embedded” into the concrete slab to assume a perfect bond. As with the tested specimens, a bolt hole of diameter 21mm on the steel beam flange was adopted to accommodate the M20 bolt whose diameter was assumed to be 20 mm. For specimen with discontinuous slabs, the gap between the edge trim surfaces was assumed to be 1 mm. Figure 12 shows a typical FE model with edge trim.

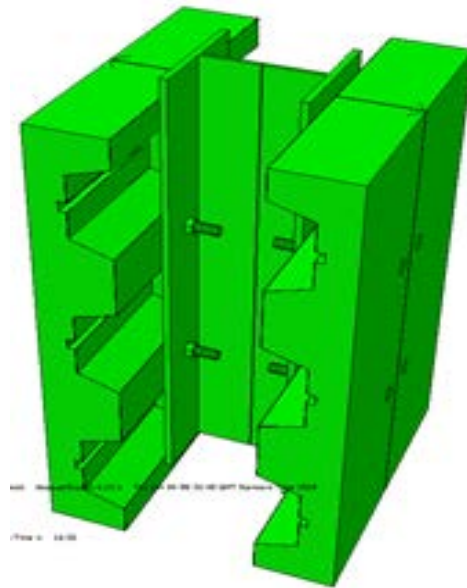

Figure 12: FE model of push test specimen

In terms of the material properties, yield strength of  $355\text{N/mm}^2$ , ultimate strength  $480\text{N/mm}^2$ , Young's modulus  $210\text{GPa}$  and Poisson's ratio  $0.3$  were used for the steel beam section. The bolt size and grade were M20 and G8.8, yield strength of  $640\text{N/mm}^2$ , ultimate strength of  $850\text{N/mm}^2$ , Young's modulus of  $210\text{GPa}$  and Poisson's ratio of  $0.3$  were specified. For the A193 reinforcing mesh, the reinforcement cage bar and U-bar, both the yield strength and ultimate strength were assumed to be  $500\text{N/mm}^2$ , Young's modulus of  $210\text{GPa}$  and Poisson's ratio equal to  $0.3$ . From profiled steel decking and edge trim, the steel grade was S350 with yield strength of  $350\text{N/mm}^2$ . For the concrete slabs, the measured compressive cube strength and the tensile splitting strength were used for the model.

### 3.2 Validation of the FE model

Figure 13 compares the predicted load vs. slip relationship of the shear connector against the test result. The comparison of the FE prediction and experimental result shows good agreement, although the FE prediction gave a higher initial stiffness than that obtained from the experimental study. The lower initial stiffness observed from test might result from the specimen imperfection and holes tolerance whereas the FE model employed an ideal boundary condition and perfect set up. If  $1\text{ mm}$  initial slip was applied (1 mm initial slip were introduced gradually from the beginning of loading to the first peak load) to the modelling results as shown in Figure 13, it would appear that the FE prediction matched the experimental results much closer.

Figure 14 shows the concrete slab crack positions and concrete damage distribution predicted by the FE model. Compared with experimental observations shown in Figure 15, it is clear that the FE model successfully captured the concrete cracks that occurred at the top surface of the slab due to the bending of the slab. Also, the FE model captured the cracks at the root of the rib resulting from the shear force transferred from the shear connectors. The positions and concrete damage patterns are similar to those observed from the tested specimens. As observed from tests, the FE prediction shows only a slight deformation in the bolts and evident deformation in the edge trims. This shows the FE model could replicate the main failure modes and damage developments observed from the experimental study.

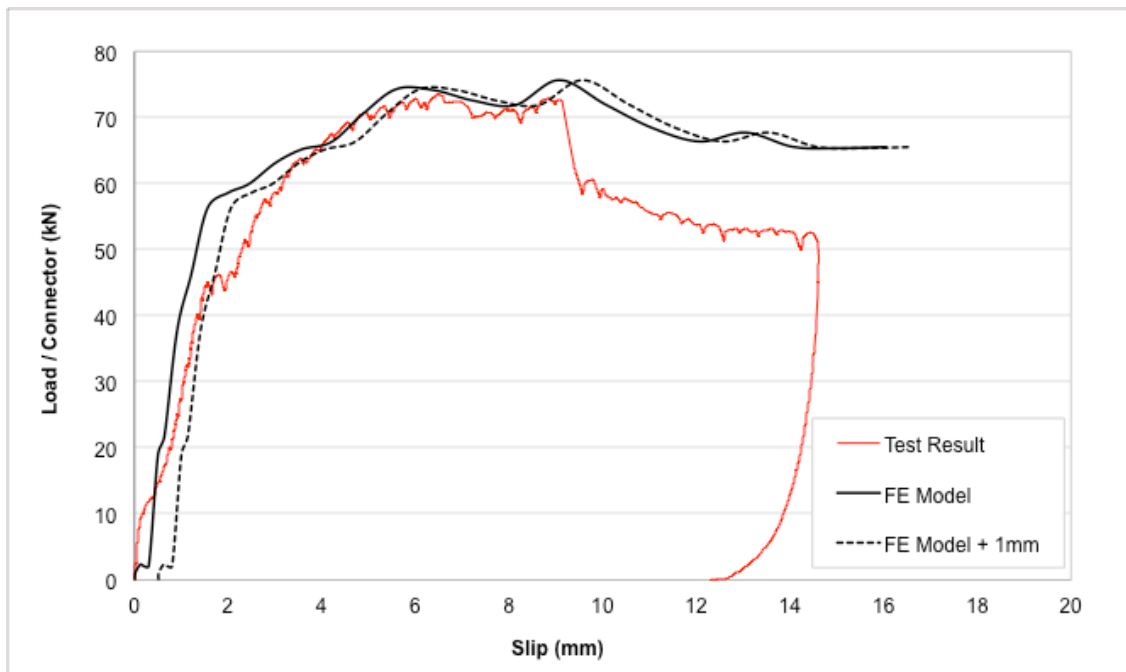

Figure 13: Test results vs. FE model

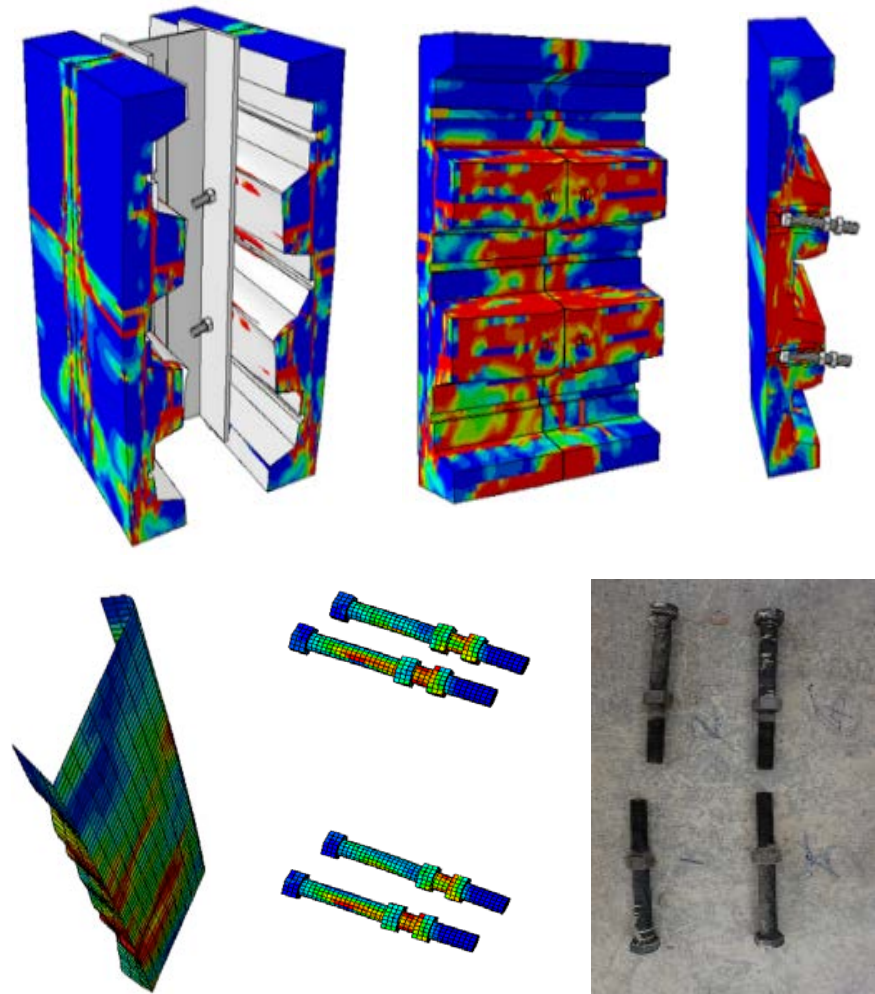

Figure 14: Failure mode shape of the push test model



Figure 15: Specimen after the push test

## 4 CONCLUSION

A series of push tests have been carried out to assess the shear resistance, stiffness and ductility of demountable shear connectors in composite slabs with profiled sheeting. A number of important parameters affect the behaviour of the shear connector resistance and slip capacity has been discussed and examined. In particular, the method and ease of deconstruction by using discontinuous and partial discontinuous slabs. Results showed that these demountable shear connectors behaved similarly to the welded counterparts but without the problem when it comes to deconstruction and reuse.

## 5 ACKNOWLEDGEMENT

The research findings given in this paper are based on a number of joint research projects and PhD studies. Funding received from the Engineering Physical Sciences Research Council and European Commission: Research Fund for Coal and Steel are greatly acknowledged.

## REFERENCES

- [1] Dallam L.N., High strength bolt shear connectors - pushout tests, *ACI J.* 1968; 65 (9): 767–769.
- [2] Marshall W.T., Nelson H.M., Banerjee H.K., An experimental study of the use of high strength friction grip bolts as shear connectors in composite beams, *Struct. Eng.* 1971; 49: 171–178.
- [3] Dedic D.J., Klaiber W.F., High strength bolts as shear connectors In rehabilitation work, *Concr. Int.* 1984; 6 (7): 41–46.
- [4] Hawkins N., Strength in shear and tension of cast in place anchor bolts, *Anchorage Concr SP-103*, 1987: 233–255.
- [5] Ataei A. Bradford MA and Liu X, Experimental study of composite beams having a precast geo polymer concrete slab and deconstructable bolted shear connectors. *Engineering Structures*, 2016; 114: 1-13.
- [6] Lee M. and Bradford M.A., Sustainable composite beam behaviour with deconstructable bolted shear connectors. *Proceeding of the Composite Construction in Steel and Concrete VII.* 2013
- [7] Ataei A and Bradford M.A., Finite element analysis of sustainable and deconstructable semi-rigid beam to column composite joints. *5th ICCM2014.* Cambridge, England. 2014; 585-590.
- [8] Pavlović M., Marković Z., Veljković M. and Buđevac D., Bolted shear connectors vs. headed studs behaviour in push-out tests. *Journal of Constructional Steel Research* 2013; 88(0): 134-149.
- [9] Moynihan M.C. and Allwood J., Viability and performance of demountable composite connectors. *Journal of Constructional Steel Research* 2014; 99: 47-56.
- [10] Lam D. and Saveri E., Shear Capacity of Demountable Shear Connectors. *Proceeding of 10th International Conference on Advances in Steel Concrete Composite and Hybrid Structures.* Singapore, 2012.
- [11] Dai X., Lam D. and Saveri E., Effect of Concrete Strength and Stud Collar Size to Shear Capacity of Demountable Shear Connectors. *Journal of Structural Engineering* 2015; 141(11).
- [12] Rehman N, Lam D, Dai X and Ashour A, Experimental study on demountable shear connectors in composite slabs with profiled decking. *Journal of Constructional Steel Research* 2016; 122: 178–189.
- [13] Rehman N, Lam D, Dai X and Ashour A., Testing of composite beam with demountable shear connectors. *Proceedings of the Institution of Civil Engineers - Structures and Buildings* 2017; 171(1): 3-16.
- [14] Eurocode 4, EN1994-1-1. Design of composite steel and concrete structures - Part 1-1: General rules and rules for buildings, European committee for standardization (CEN), Brussels, Belgium, 2004.

- [15] ABAQUS. Analysis user's manuals and example problems manuals, version 6.14. Providence, Rhode Island: Abaqus Inc.; 2014.