

bradscholars

Performance analysis and capacity assignment optimisation of wireless cells with re-use partitioning

Item Type	Article
Authors	Kouvatsos, Demetres D.;Awan, Irfan U.;Al-Begain, Khalid;Tantos, Sotiris
Citation	Kouvatsos, D.D., Awan, I. Al-Begain K. and S. Tantos (2002). Performance analysis and capacity assignment optimisation of wireless cells with re-use partitioning. International Journal of Simulation. Vol. 3 Nos 1-2, 56-67.
Rights	© United Kingdom Simulation Society. Reproduced in accordance with the publisher's self-archiving policy.
Download date	2026-04-13 05:29:56
Link to Item	http://hdl.handle.net/10454/468

PERFORMANCE ANALYSIS AND CAPACITY ASSIGNMENT OPTIMISATION OF WIRELESS CELLS WITH RE-USE PARTITIONING*

D.D. KOUVATSOS, I.AWAN, K. AL-BEGAIN and S.TANTOS

*Performance Modelling and Engineering Research Group
Department of Computing, School of Informatics
University of Bradford, Bradford,
BD7 1DP Bradford, West Yorkshire, England, UK
E-mail : {d.d.kouvatsos, i.awan,k.begain, s.tantos}@brad.ac.uk,*

Abstract: This paper presents a novel and efficient analytic framework for the performance analysis and capacity-assignment optimisation of a wireless GSM cell employing the Re-Use Partitioning (RUP) policy. RUP splits hierarchically the available bandwidth into multiple layers of frequencies and allows tighter frequency re-use in order to achieve a higher network capacity. In this context, a queueing network model (QNM) of a wireless cell is proposed consisting of a hierarchical layer configuration which is decomposed into individual GE/GE/c/c loss systems each of which is analysed in isolation via a more general maximum entropy (ME) state probability solution, subject to appropriate GE-type flow formulae and mean value constraints. Moreover, a new performance optimisation index is proposed as the weighted average non-blocking probability of traffic over all frequency layers. For illustration purposes, the proposed index is utilised to formulate and solve two capacity-assignment optimisation problems. Numerical examples are included to validate the relative accuracy of the analytic GE-type performance metrics against simulation and assess the optimal re-use partitioning policy of the available bandwidth.

Key Words: Wireless GSM cell, Re-use partitioning, Queueing network model, Generalised exponential distribution, Maximum entropy principle.

1 INTRODUCTION

Performance issues are being increasingly experienced by mobile network operators due to the limited capacity of Global Systems for Mobile Communication (GSM) [Mouly and Pautet 1992] which combine frequency and time division techniques (FDM/TDM). It is widely envisaged that these issues will be resolved by the introduction of third generation mobile systems, such as the Universal Mobile Telecommunication System (UMTS), based on Wideband Code Division Multiple Access (WCDMA) [Dahlman et al, 1998]. Nevertheless, this technological transition is going to take place gradually as major changes and investment are required in the infrastructure of mobile networks. Thus, cost-effective solutions to improve the utilisation of the available bandwidth and other performance mea-

asures of existing GSMs are still of great importance to both mobile users and network operators. Such solutions can be based on the reduction of the cell size, the optimisation of the frequency allocation and the enhancement of the frequency re-use. However, the former two solutions have inherent limitations due to interference.

The re-use partitioning (RUP) principle (otherwise known as concentric cell or intelligent underlay-overlay - IUO) can be used to improve the re-usability frequencies in a wireless GSM cell and enhance its overall performance. RUP splits the available bandwidth into multiple layers of frequencies and allows a tighter frequency re-use in order to achieve a higher network capacity. The RUP principle has been widely applied in the literature (e.g., [Pattavina et al, 1999, Halpern, 1983, Kanai, 1992, Furukawa and Akaiwa, 1993, Frodigh, 1995, Zander

*This work is supported by the EU IST Programme under grant IST-2001-32392

and Frodigh, 1992, Papavassiliou et al, 1994, Begain et al, 2002, Begain et al, 2001, Begain et al, 2001a).

An RUP study, including dynamic channel allocation and an assessment regarding the effect of mobility, has been presented in [Pattavina et al, 1999]. The reported numerical results show that the capacity of the proposed scheme is higher than that of a dynamic channel allocation without RUP. [Halpern, 1983] has shown that RUP has the potential for increasing the system radio capacity with minimal impact on the base station architecture. An interference adaptive dynamic frequency allocation exploiting RUP is presented in [Kanai, 1992], where the performance of a simple decentralised algorithm with fixed and uniformly distributed users was evaluated. A more sophisticated algorithm is devised in [Furukawa and Akaiwa, 1993] to achieve frequency re-use at the expense of an increased interbase signalling load. A dynamic channel assignment is investigated in [Frodigh, 1995] for a mono-dimensional cellular system with RUP. [Zander and Frodigh, 1992] focus on a static capacity allocation and channel assignment for cellular systems with RUP based on K different re-use capacity patterns. [Papavassiliou et al, 1994] consider a cellular system with different re-use profiles and a fixed channel allocation for balancing uniformly the blocking probability throughout the cell. A detailed analytical model to investigate the effect of RUP mobility parameters on the blocking and handover failure probabilities was suggested in [Begain et al, 2002]. Moreover, [Begain et al, 2001] proposed an operational expression to calculate the spectrum efficiency index of a GSM cell with RUP and carried out a numerical study for the bandwidth partitioning via MOSEL language [Begain et al, 2001a].

The quantitative analysis of earlier proposed performance evaluation models for a wireless GSM cell with RUP has been restricted to a limited number of layers and was mostly based on either costly discrete event simulation or numerical solutions subject to simplified Markovian assumptions. As a consequence, the impact of bursty mobile traffic on the performance of the cell has not been adequately investigated. Moreover, there is further need to search for more advanced analytical methods to identify optimal RUP corresponding to a maximum performance gain.

In this paper a novel and efficient analytic framework is devised for the performance modelling and evaluation of a wireless GSM cell employing RUP policy. A queueing network model (QNM) of an GSM cell is proposed consisting of a hierarchical layer configuration which is decomposed into indi-

vidual GE/GE/c/c loss models with generalised exponential (GE) interarrival and service time distributions. Each model can then be analysed in isolation via the principle of entropy maximisation (ME) [Kouvatsos, 1994]. Moreover, a new performance optimisation index (POI) is proposed as the weighted average non-blocking probability of traffic over all frequency layers and, for illustration purposes, two two capacity-assignment optimisation problems are presented. Numerical examples are included to validate the relative accuracy of the analytic GE-type performance metrics against simulation and assess the optimal re-use partitioning policy of the available bandwidth.

The principle of re-use partitioning is described in Section 2. The ME analysis of a QNM of a wireless GSM cell with RUP is presented together with GE-type flow formulae in Section 3. The GE/GE/c/c loss system is analysed, as a cost effective building block, via entropy maximisation in Section 4. Numerical tests on the credibility of the proposed algorithm and the performance impact of bursty external GSM traffic are presented in Section 5. Section 6 defines a Performance Optimisation Index and presents two capacity-assignment optimisation problems with numerical results. Conclusions follow in Section 7.

2 THE PRINCIPLE OF RE-USE PARTITIONING

The RUP is a feature designed to allow a tighter frequency reuse for some of the available radio frequencies and therefore achieve a higher network capacity. It implements a multi-layer network structure with a different reuse factor for each layer. As a particular solution based on RUP, Nokia [Nokia, 2002] proposed a special implementation with two-layer network structure called Intelligent Underlay-Overlay (IUO). The underlay adds capacity, the overlay provides coverage. To maintain optimum capacity, the base station assigns mobile traffic to either layer of the network according to actual interference levels. The IUO solution splits the available frequency spectrum into two bands. One band consists of frequencies that can only be used when a high C/I ratio is ensured, the *super* frequencies, where C/I denotes a ratio of carrier (C) over interference (I). Super frequencies are usually used only near the Base Transceiver Station (BTS). The other band contains frequencies that can be used throughout the whole cell, the *regular* frequencies. Note that the calculation of C/I ratio is based on measurements carried out by the mobile station.

Every IUO cell has *regular* and *super* Transmitter Receivers (TRXs). Regular frequencies completely cover the cell. These frequencies can be reused by conventional criteria, using safe hand-over bounds to provide low probabilities for interference. Mobile stations are assigned to regular frequencies at the boundary where C/I ratio is under a specific level. Figure 1 shows the principle of the layer structure of IUO.

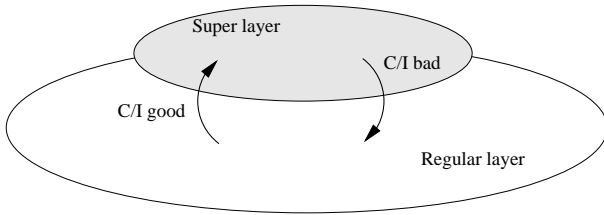

Figure 1: IUO principle

Super frequencies provide services in heavy traffic areas (downtown) of the cell, where C/I rate is good (interference free area). Using different C/I ratios, the coverage of the super layer (super frequencies) can be controlled. If IUO is combined with downlink power control, even better interference conditions can be maintained resulting in better call quality. A detailed performance analysis of a GSM cell using IUO was presented in [Begain et al, 2002] based on numerical solution (Markov Chain).

In this paper, the work is extended in three ways. First, the limit on the number of layers is removed which allows to study the RUP principle for any finite number of layers. Second, the performance modelling is based on an analytical solution involving bursty GE-type traffic and Maximum Entropy (ME) principle. Finally, the investigation is extended to capacity assignment optimization by introducing a new performance optimization index.

3 A QUEUEING NETWORK MODEL (QNM)

Consider a queueing network model (QNM) of a wireless GSM cell with RUP which splits the available bandwidth into $L + 1$ ($L \geq 1$) layers consisting of different frequencies corresponding to a sequence of descending thresholds $\{R_1 < \dots < R_L\}$. The ℓ^{th} layer ($\ell = 1, 2, \dots, L-1$) is called super layer- ℓ containing 'super' frequencies which can be used by the mobile station over the ℓ^{th} layer if $R_\ell < C/I < R_{\ell+1}$. The layer with the highest 'super' frequencies is

called 'super' layer- L and can be used if $C/I > R_L$. Finally, the first layer with the lowest frequencies is called 'regular' layer. The 'regular' frequencies corresponding to $\ell = 0$ can be used over the entire cell when ratio $C/I < R_1$. Fig.2 shows the operation of a wireless GSM cell under RUP.

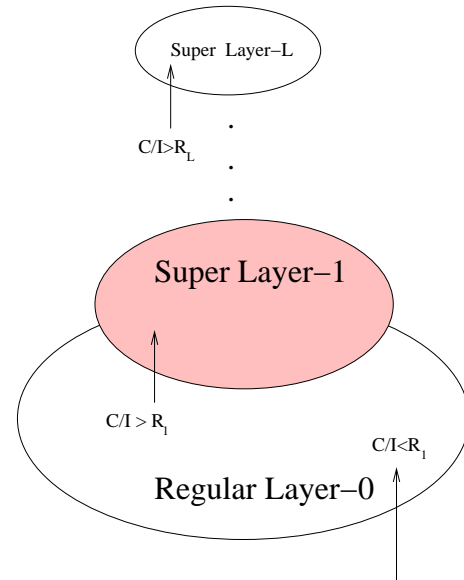

Figure 2: Wireless GSM cell with RUP

A QNM of the wireless GSM cell with RUP is displayed in Fig.3 and is based under the following assumptions:

- No movement is considered in the mobile station. (The C/I ratio for each user remains constant during the duration of the call)
- Traffic over the network is homogeneous and uniformly distributed.
- The interarrival times follow a generalised exponential (GE) distribution with mean value, $1/\lambda$ and squared coefficient of variation (SCV), C_a^2 .
- The call duration follows a GE distribution with mean value, $1/\mu$ and SCV C_s^2 .

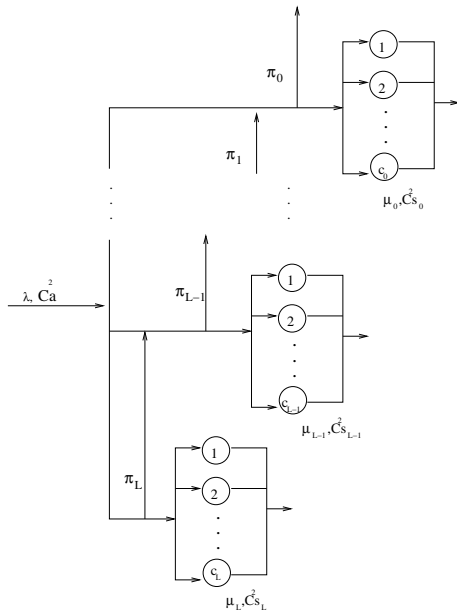

Figure 3: The QNM of the GSM cell with RUP

3.1 Definitions and Notations

λ : External mean arrival rate of calls in the system

C_a^2 : SCV of external interarrival time of calls in the system.

For each layer- ℓ ($\ell = 0, 1, 2, \dots, L$)

c_ℓ : Number of available channels

$1/\mu_\ell$: Mean call duration

$C_{st\ell}^2$: SCV of the transmission time

cov_ℓ : Ratio of the area covered by layer- ℓ over the entire area covered by regular layer 0 (n.b., $cov_0 = 1$ with $\mathbf{cov} = (cov_1, cov_2, \dots, cov_L)$).

λ_ℓ : External arrival rate of calls at layer- ℓ

Λ_ℓ : Overall arrival rate of calls at layer- ℓ

C_{al}^2 : SCV of the overall interarrival time (splitting) distribution of those calls entering to the super layer- ℓ .

\hat{C}_{al}^2 : SCV of the overall interarrival time distribution of the merging calls attempting to enter the layer- ℓ

π_ℓ : Probability of an arriving call to find all channels in layer- ℓ busy

p_ℓ : Probability of an arriving call to attempt to enter in layer- ℓ

$$p_\ell = cov_\ell - cov_{\ell+1} \quad (\ell = 0, 1, \dots, L-1), \quad (1)$$

$$p_L = cov_L, \quad (2)$$

satisfying $\sum_\ell p_\ell = 1$.

For each super layer- $\ell, \ell = 1, 2, \dots, L$, let

$\Lambda_{b\ell}$: Overall arrival rate of calls being blocked at layer- ℓ , and

$C_{b\ell}^2$: SCV of the overall interarrival time distribution of the calls being blocked on the layer- ℓ .

3.2 ME Product-Form Approximation

The principle of ME has been used as in earlier works (e.g., [Kouvatsos, 1994, Kouvatsos and Xenios, 1989]), to characterise a product form approximation for arbitrary QNMs, subject to appropriate GE-type queueing theoretic constraints. More specifically, the form of the ME joint state probability $P(\mathbf{n}), \mathbf{n} = (n_0, n_1, n_2, \dots, n_L)$, where n_0 is the number of calls in regular layer and n_ℓ is the number of calls in super layer- $\ell, \ell = 1, 2, \dots, L$, can be established by applying the method of Lagrange's undetermined multipliers and is given by

$$P(\mathbf{n}) = \prod_{\ell=0}^L P_\ell(n_\ell), \quad (3)$$

where $\{P_\ell(n_\ell), n_\ell = 0, 1, \dots, c_\ell\}$ are the exact marginal state probabilities of the GE/GE/ c_ℓ/c_ℓ loss system at layer- ℓ ($\ell = 0, 1, \dots, L$).

Viewing the GE/GE/ c_ℓ/c_ℓ loss system as a building block queue within the decomposition process, the $P_\ell(n_\ell)$ state probability is a trivial case of the exact ME solution of a stable GE/GE/ c_ℓ/N_ℓ ($c_\ell \leq N_\ell$) queue with finite N_ℓ , subject to the normalisation and the constraints of server utilisations $\{1 - p_\ell(0), 1 - p_\ell(0) - p_\ell(1), \dots, 1 - p_\ell(0) - \dots - p_\ell(c_{\ell-1})\}$, the mean number of waiting calls (i.e., $\sum_{n_\ell=c_\ell}^{N_\ell} (n_\ell - c_\ell) P_\ell(n_\ell)$) and the full buffer state probability $P_\ell(N_\ell)$. For more details see [Kouvatsos and Xenios, 1989].

The ME product form approximation allows the decomposition of the QNM into $L + 1$ GE/GE/ c_ℓ/c_ℓ loss systems, each of which can be solved in isolation. This can be achieved in conjunction with GE-type flow formulae relating to the mean and SCV of the merging and splitting GE-type flows (c.f., [Kouvatsos, 1994, Kouvatsos and Xenios, 1989]).

The GE distribution and GE-type formulae are presented below.

3.2.1 The GE Distribution

The GE distribution is of the form

$$\begin{aligned}
 F(t) &= P(X \leq t) \\
 &= 1 - \tau e^{-\tau vt}, t \geq 0,
 \end{aligned}
 \tag{4}$$

where $\tau = 2/(C^2 + 1)$, X is the interevent time random variable and $\{1/v, C^2\}$ are the mean and squared coefficient of variation (SCV) of the interevent time distribution, respectively (c.f.,[Kouvatsos, 1994]). Note that the underlying counting process of the GE distribution is a compound Poisson process with geometrically distributed batch sizes and mean batch size $1/\tau = (C^2 + 1)/2$.

3.2.2 GE-Type Flow Formulae

- Splitting Formulae

For $\ell = 0, 1, \dots, L$

$$\lambda_\ell = \lambda p_\ell, \tag{5}$$

$$C_{a\ell}^2 = (1 - p_\ell) + p_\ell C_a^2, \tag{6}$$

$$C_{b\ell}^2 = (1 - \pi_\ell) + \pi_\ell C_{al}^2. \tag{7}$$

- Merging Formulae

For $\ell = 0, 1, \dots, L - 1$

$$\Lambda_{b\ell} = \Lambda_{\ell+1} \pi_{\ell+1}, \tag{8}$$

$$\Lambda_\ell = \lambda_\ell + \Lambda_{b\ell}, \tag{9}$$

$$\begin{aligned}
 \hat{C}_{a\ell}^2 &= -1 + \left(\frac{\lambda_\ell}{\Lambda_\ell} (C_{a\ell}^2 + 1) \right)^{-1} \\
 &\quad + \frac{\Lambda_{b\ell}}{\Lambda_\ell} (C_{b\ell+1}^2 + 1)^{-1},
 \end{aligned}
 \tag{10}$$

$$\Lambda_L = \lambda_L, \tag{11}$$

$$\hat{C}_{aL}^2 = C_{aL}^2. \tag{12}$$

4 PERFORMANCE ANALYSIS OF GE/GE/ c_ℓ/c_ℓ LOSS SYSTEM

This section applies entropy maximisation to determine the state probability distribution of a typical GE/GE/ c/N queue with $c > 0$ servers and finite capacity $N(\geq c)$ and, subsequently, analyses, as a special but trivial case, a GE/GE/ c_ℓ/c_ℓ loss system ($\ell = 0, 1, \dots, L$). The latter system plays the role of a cost-effective building block in the decomposition process of the proposed QNM.

4.1 The ME Solution of the GE/GE/ c/N Queue

Consider a first-come-first-served (FCFS) GE/GE/ c/N virtual queue with finite capacity $N(\geq c)$ and GE-type interarrival and service time distribution with mean rates and SCVs (λ, C_a^2) and (μ, C_s^2) , respectively.

4.1.1 Prior Information

Suppose, in context of entropy maximisation, the following mean value constraints about the state probabilities $\{P(n), n = 0, 1, \dots, N\}$ of a GE/GE/ c/N queue are known to exist:

- (i) Normalisation,

$$\sum_{n=0}^N P(n) = 1. \tag{13}$$

- (ii) The probabilities (or, server ‘utilisation’) $\{U(k)\}$, i.e.,

$$U(k) = \sum_{n \geq k}^N P(n), k = 1, 2, \dots, c; \tag{14}$$

where $U(k) \in [0, 1]$.

- (iii) The mean number of waiting calls $L(n - c)$, i.e.,

$$L(n - c) = \sum_{n=0}^N h(n)P(n), \tag{15}$$

where $h(n) = n - c$, for $n > c$ or 0, otherwise.

- (iv) The state probability of a full queue, $P(N) = \phi$ (satisfying the flow balance condition) i.e.,

$$\phi = \sum_{n=0}^N f(n)P(n), \tag{16}$$

where $\phi \in [0, 1]$ and $f(n) = 0$, for $n = 0, 1, \dots, N - 1$ or 1 for $n = N$.

Although at this stage the mean value constraints $\{U(k), k = 1, 2, \dots, c\}$, $\{L(n - c)$ and ϕ are not explicitly known in terms of input parameters (such as $\lambda, C_a^2, \mu, C_s^2$ and N), nevertheless they can be incorporated into the ME formalism in order to determine the form of ME solution.

4.1.2 Entropy Maximization

The form of the ME state probability $\{P(n), n = 0, 1, \dots, N\}$ can be completely characterised by maximising the entropy functional

$$H(P) = - \sum_{n=0}^N P(n) \log P(n), \tag{17}$$

subject to prior information expressed by constraints (13)-(16). By employing Lagrange's method of undetermined multipliers, the maximisation of (17), subject to constraints (13)-(16), leads to an exact ME solution, namely

$$P(n) = \frac{1}{Z} \left[\prod_{k=1}^c g(k) \right] x^{h(n)} y^{f(n)}, \quad (n = 1, 2, \dots, N), \quad (18)$$

where $Z = 1/P(0)$ is the normalising constant and $\{g(k), k = 1, 2, \dots, c\}$, x and y are the Lagrangian coefficients corresponding to constraints (14)-(16), respectively. It can be verified by inspection that ME solution (18) reduces to that of the classical M/M/c/N queue. Indeed, the a priori knowledge of the exact solution of the later queue provides the motivation for the choice of the mean value constraints (13)-(16). It is interesting to note that the form of the ME solution (18) can be generalised to an extended ME solution for a more complex queue originally proposed in [Kouvatsos and Xenios, 1989].

4.1.3 The Lagrangian Coefficients

The Lagrangian Coefficients x , $\{g(k), k = 0, 1, \dots, c\}$, y can be determined by making asymptotic invariance connections to the infinite capacity GE/GE/c queue [Kouvatsos, 1994] and are given by

$$g(k) = \begin{cases} \frac{tc\rho}{s(1-t)+t}, & k = 1 \\ \frac{tc\rho}{t\rho(1-s)+s}, & k \in [2, c-1] \\ \frac{s(1-t)+t}{t\rho(1-s)+s} t\rho, & k = c \end{cases} \quad (19)$$

$$x = \frac{t\rho + s(1-t)}{t\rho(1-s) + s}. \quad (20)$$

Finally, the Lagrangian coefficient y can be determined via the flow balance condition of the GE/GE/c/N queue and is given by

$$y = \frac{1}{1 - (1-s)x}, \quad (21)$$

where $\rho = \lambda/\mu$, $t = 2/(C_a^2 + 1)$ and $s = 2/(C_s^2 + 1)$.

4.2 The GE/GE/ c_ℓ/c_ℓ Loss System

The GE/GE/ c_ℓ/c_ℓ ($\ell = 0, 1, \dots, L$) loss system is a special case of the GE/GE/c/N queueing system with $N = c_\ell$. Clearly, the ME solution of the GE-type loss system is trivial since $c_\ell + 1$, the total number of states, is equal to the number of constraints of the type (13)-(16) (n.b., constraint (15) is not applicable i.e., $N = c_\ell$, $L_\ell(n_\ell - c_\ell) = 0 \forall n_\ell \geq c_\ell$).

The marginal ME state and blocking probabilities of a GE/GE/ c_ℓ/c_ℓ loss system, respectively, can be determined as follows:

4.2.1 The Marginal ME Queue Length Distribution

The marginal state probability, $\{P_\ell(n_\ell), n_\ell = 0, 1, \dots, c_\ell\}$, of a GE/GE/ c_ℓ/c_ℓ queue ($\ell = 0, 1, \dots, L$) can be determined by utilising ME solution (18) and are given by

$$P_\ell(n_\ell) = \begin{cases} P_\ell(0)G_\ell(n_\ell), & \text{for } n_\ell = 1, 2, \dots, c_\ell - 1 \\ P_\ell(0)G_\ell(n_\ell)y_\ell, & \text{for } n_\ell = c_\ell \end{cases} \quad (22)$$

where

$$P_\ell(0) = \left(1 + \sum_{n=1}^{c_\ell-1} G_\ell(n_\ell) + G_c y_\ell \right)^{-1}, \quad (23)$$

$$G_\ell(n_\ell) = \prod_{k=1}^{n_\ell} g_\ell(k), \quad n_\ell = 1, 2, \dots, c_\ell. \quad (24)$$

with $g_\ell(k)$, ($\ell = 0, 1, \dots, L$) being determined by (19).

4.2.2 The Blocking Probability

By using GE-type probabilistic arguments, it can be verified that the blocking probability, π_ℓ , is given by

$$\pi_\ell = \sum_{n_\ell=0}^{c_\ell-1} \left(\frac{s_\ell(1-t_\ell)}{s_\ell(1-t_\ell)+t_\ell} \right)^{c_\ell-n_\ell} P_\ell(n_\ell) + P_\ell(c_\ell), \quad (25)$$

$\ell = 0, 1, \dots, L$, where $t_\ell = 2/(C_{a_\ell}^2 + 1)$ and $s_\ell = 2/(C_{s_\ell}^2 + 1)$.

5 QUEUEING NETWORK MODEL VALIDATION

This section presents some typical numerical experiments in order to illustrate the credibility of the ME closed-form expressions of the proposed QNM of the GSM cell with RUP against simulation using the Queueing Network Analysis Package QNAP-2 [Veran and Potier, 1985] at 95% confidence intervals and also assess the optimal re-use partitioning policy of the available bandwidth.

The wireless GSM cell considered in this section comprises from 4 layers ($L = 3$) with coverage values for the three super layers given as $cov_1 = 0.8$, $cov_2 = 0.6$, and $cov_3 = 0.3$, respectively. It is assumed that each layer operates one frequency carrier which give 8 GSM channels for each layer according to the FDMA/TDMA scheme [Mouly and Pautet 1992]. For all figures 4-9, the following input data are assumed: $\mu_\ell = \mu = 0.011/s$ and $C_{s_\ell}^2 = C_s^2 = 5$

($\ell = 0, 1, 2, 3$). Figures 4-8 show the impact of varying the input call rate, λ , with $C_a^2 = 10$. Moreover, Fig. 9 shows the effect of varying the SCV, C_a^2 , with fixed rate $\lambda = 0.15$ call/s. The comparative study focuses on the three important measures of utilisation, mean queue length (number of calls in the system) and call blocking probability.

It can be observed (c.f., Fig. 4-8) that the ME solutions are very comparable in accuracy to those obtained by corresponding simulation results. Moreover, it can be seen (c.f., Fig. 9) that the analytically established call loss probability increases rapidly with increasing external interarrival-time SCVs (or, equivalently, average batch sizes).

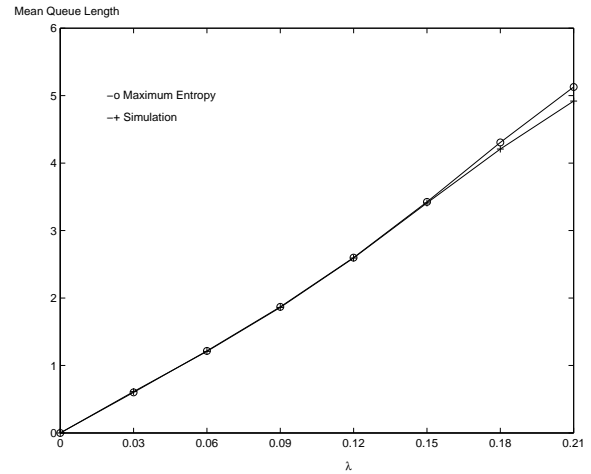

Figure 6: Mean number of calls at layer 1

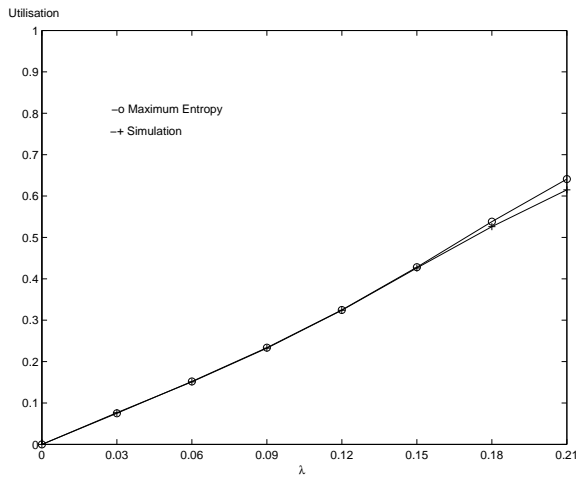

Figure 4: Utilisation of the layer 1

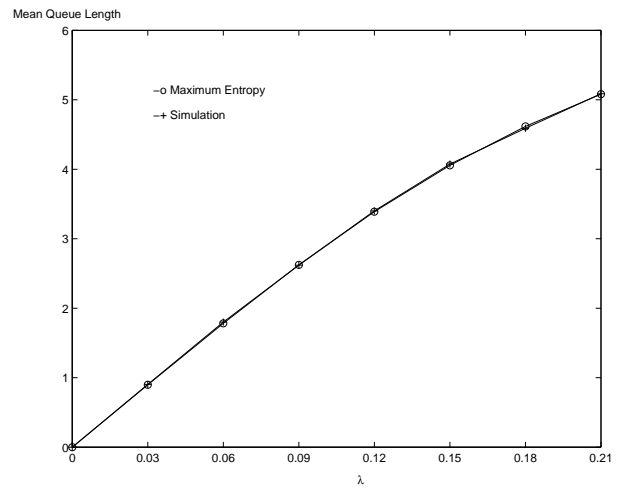

Figure 7: Mean number of calls at layer 3

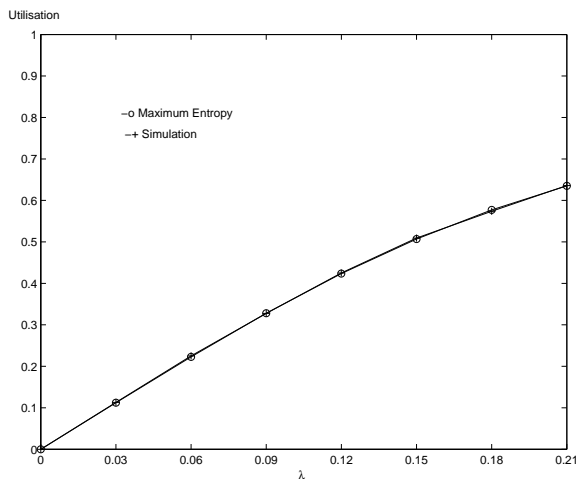

Figure 5: Utilisation of the layer 3

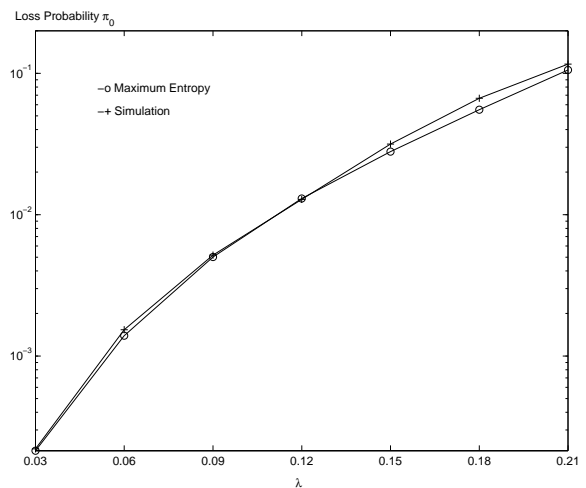

Figure 8: Call Loss Probability

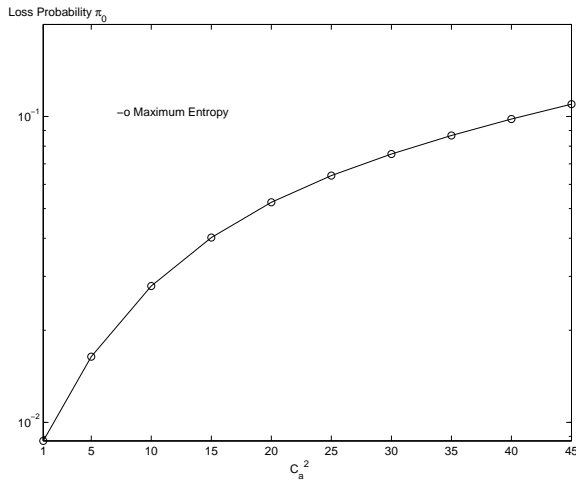

Figure 9: Effect of varying degrees of C_a^2 on Call Loss Probability

6 CAPACITY-ASSIGNMENT OPTIMISATION

This section defines a new performance optimisation index (POI) for studying two capacity-assignment optimisation problems for wireless GSM cells with RUP. The optimisation problem 1 involves the maximisation of the POI with respect to an exhaustive set of coverages $\{\mathbf{cov}\}$, subject to specific values for the input parameters. Moreover, the optimisation problem 2 focuses on the maximisation of POI with respect to an exhaustive set of coverages $\{\mathbf{cov}\}$, subject to specific values of input parameters other than λ satisfying a fixed value for loss probability π_0 .

6.1 Optimisation Problem 1

Given $L, \lambda, C_a^2, \mathbf{c} = (c_0, c_1, \dots, c_L), \mu_\ell, C_{s\ell}^2 (\ell = 0, 1, \dots, L)$

$$\max_{\mathbf{cov}} \{ \mathbf{POI} = \sum_{\ell=0}^L p_\ell (1 - \pi_\ell) \},$$

subject to

$$cov_L < \dots < cov_{\ell+1} < cov_\ell < \dots < cov_0 = 1.$$

- Example 1: $L=1$

Input data $\{ \lambda = 0.1, C_a^2 = 10, \mathbf{c} = (8, 8), \mu_\ell = 0.01, C_{s\ell}^2 = 4 (\ell = 0, 1) \}$

Maximizing POI with respect to \mathbf{cov} indicates that the optimal value of coverage is $cov_1=0.4641$ (see Fig.10).

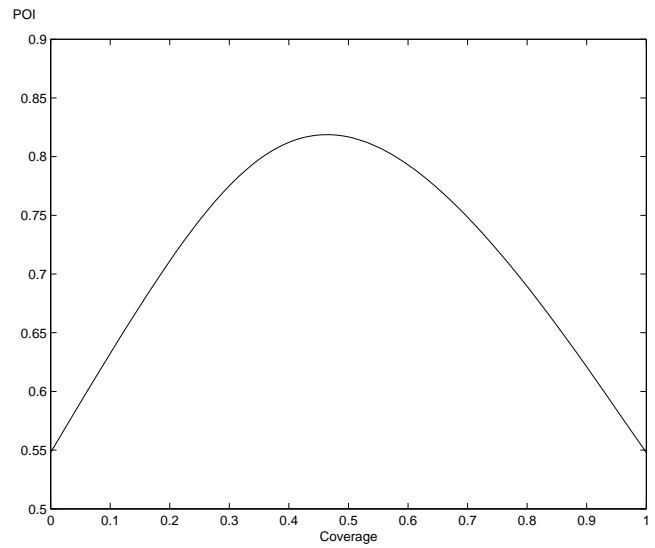

Figure 10: Example of problem 1 for an (8-8) system

- Example 2: $L=2$

Input data $\{ \lambda = 0.1, C_a^2 = 10, \mathbf{c} = (8, 8, 8), \mu_\ell = 0.01, C_{s\ell}^2 = 4 (\ell = 0, 1, 2) \}$

Maximizing POI with respect to \mathbf{cov} reveals that the optimal pair of coverages is $(cov_1, cov_2) = (0.65, 0.33)$ (see Fig. 11).

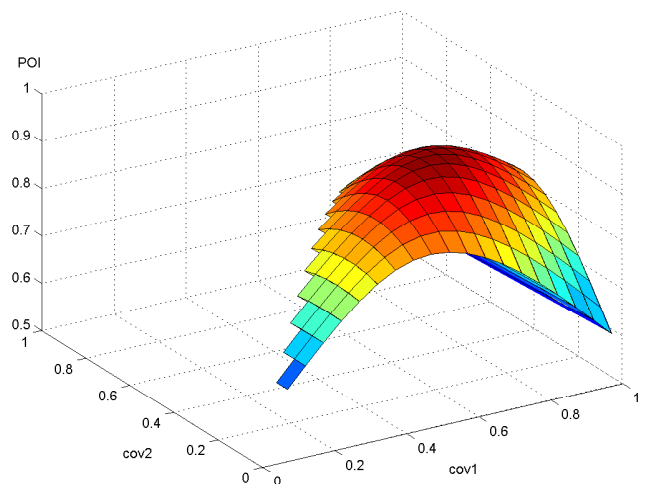

Figure 11: Example of problem 1 for an (8-8-8) system

6.2 Optimisation Problem 2

Given $L, C_a^2, \mathbf{c} = (c_0, c_1, \dots, c_L), \mu_\ell, C_{s\ell}^2 (\ell = 0, 1, \dots, L)$;

$$\max_{\lambda, \mathbf{cov}} \{ \mathbf{POI} = \sum_{\ell=0}^L p_\ell (1 - \pi_\ell) \},$$

subject to the solutions of the non-linear equation

$$\pi_0(\mathbf{cov}, \lambda) = \epsilon, \tag{26}$$

with respect to λ and for a given \mathbf{cov} satisfying $cov_L < \dots < cov_{\ell+1} < cov_\ell < \dots < cov_0 = 1$. Note that the solutions $\{\lambda\}$ correspond to an exhaustive set of coverage values $\{\mathbf{cov}\}$, where π_0 is the call loss probability at the regular layer $\ell = 0$ and ϵ is a small % value (e.g., $\epsilon = 0.02$).

- Example 1: L=1

Input data $\{\epsilon = 0.02, C_a^2 = 10, \mathbf{c} = (8, 8), \mu_\ell = 0.01, C_{s\ell}^2 = 4(\ell = 0, 1)\}$

Maximizing POI with respect to $\{\lambda, \mathbf{cov}\}$ indicates that the optimal value of coverage is $cov_1=0.3787$ (see Fig. 12).

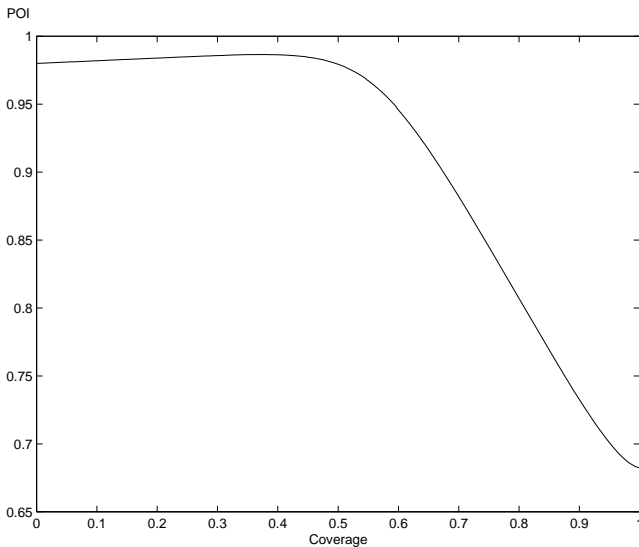

Figure 12: Example of problem 2 for an(8-8) system

- Example 2: L=2

Input data $\{\epsilon = 0.02, C_a^2 = 10, \mathbf{c} = (8, 8, 8), \mu_\ell = 0.01, C_{s\ell}^2 = 4(\ell = 0, 1, 2)\}$

Maximizing POI with respect to $\{\lambda, \mathbf{cov}\}$ reveals that the optimal pair of coverages is $(cov_1, cov_2) = (0.54, 0.27)$ (see Fig.13)

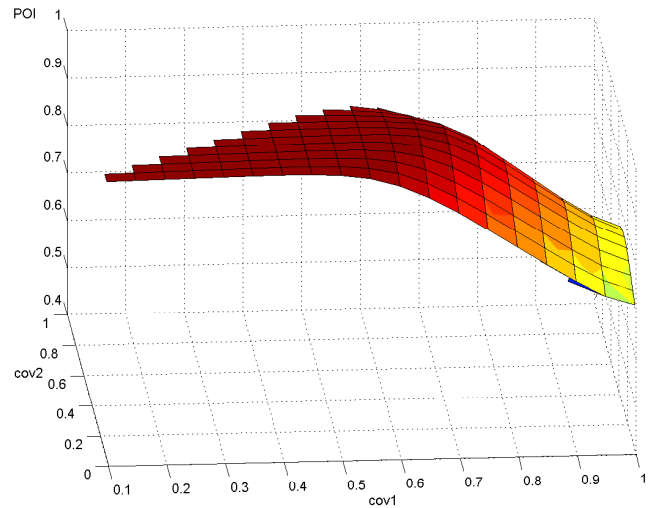

Figure 13: Example of problem 2 for an (8-8-8) system

Finally, assuming without loss of generality, that all frequency layers have the same $C_{s\ell}^2 = C_s^2$, Figs 14, 15 and 16 illustrate the impact of λ and the variability effect of C_a^2 and C_s^2 , respectively, on the POI of the GSM cell with RUP. It can be observed that the performance of the cell deteriorates for larger values of C_a^2 corresponding to smaller values of C_s^2 . This is attributed to the fact that the smaller C_s^2 is the less the average size of the departing bulk and, thus, the larger the number of calls in the system.

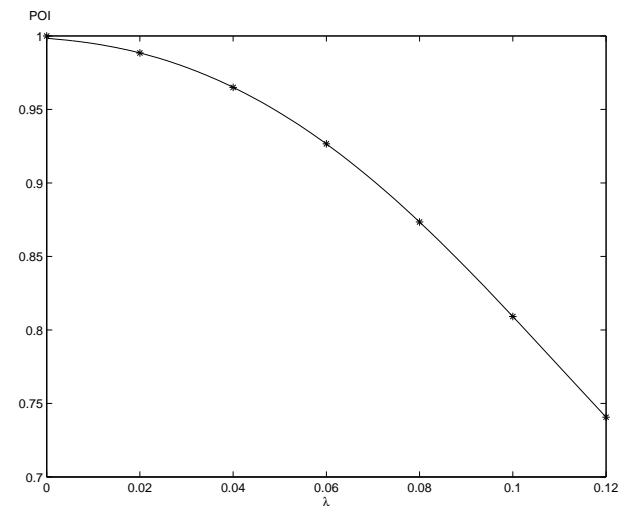

Figure 14: $L = 1, \mathbf{c} = (8, 8), cov_1 = 0.6, C_a^2 = 10, C_{s\ell}^2 = 5, \mu_\ell = 0.01, \ell = 0, 1$

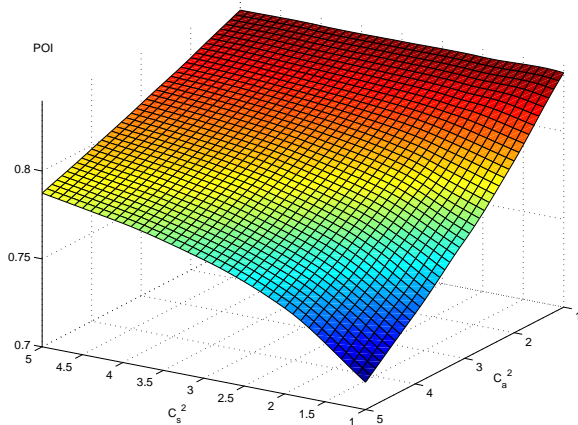

Figure 15: $L = 1, \mathbf{c} = (8, 8), cov_1 = 0.6, \lambda = 0.12, \mu_\ell = 0.01, \ell = 0, 1$

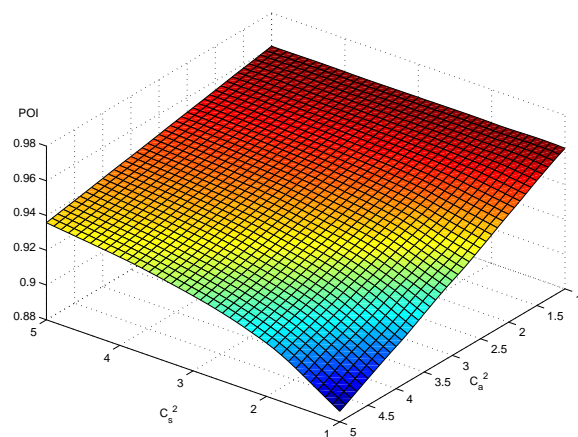

Figure 16: $L = 2, \mathbf{c} = (8, 8, 8), (cov_1, cov_2) = (0.7, 0.4), \lambda = 0.12, \mu_\ell = 0.01, \ell = 0, 1, 2$

7 CONCLUSIONS AND FURTHER WORK

A novel and efficient analytic framework is devised for the performance modelling and evaluation of a wireless GSM cell with RUP policy. A QNM of a wireless GSM cell is proposed consisting of a hierarchical layer configuration which is decomposed into individual GE/GE/c/c loss models each of which is analysed in isolation via the principle of ME. A comparative study is included to validate the relative accuracy of the derived ME closed-form expressions against simulation and also assess the effect of external GSM bursty traffic upon the performance of the cell. It is shown that traffic burstiness has adverse implications on the performance of the mobile

cell. Moreover, a new performance optimisation index (POI) is proposed as the weighted average non-blocking probability of traffic over all frequency layers and, for illustration purposes, it is utilised to formulate and solve two capacity-assignment optimisation problems. Numerical examples are included to assess the best RUP policy of the available bandwidth and determine the optimal values of super layer coverages corresponding to the maximum performance gain.

The new analytic results provide simple and practical means for credible performance modelling and prediction studies involving mobile GSM networks. The work is currently extended towards the performance modelling and analysis of arbitrary networks of GSM/GPRS cells and 3G mobile systems.

References

- Begain K., Bolch G. and Herold H. 2001, "Practical Performance Modeling, Application of MOSEL Language", *Kluwer Academic Publishers*.
- Begain K., Zreikat A.I. and Li Y. 2001, "Optimising Capacity in GSM", *Modelling and Simulation 2001*, E. Kerchhoffs and M. Snorek (eds.), SCS Publications. pp. 841-845.
- Begain K., Pfening A., Rozsa G.I. and Telek M. 2002, "Performance of GSM Networks with Intelligent Underlay-Overlay", *Seventh IEEE Symposium on Computers and Communications (ISCC'02)*, Italy.
- Dahlman E., Gudmundson B., Nilsson M. and Skoeld J. 1998, "UMTS/IMT-2000 Based on Wideband CDMA", *IEEE Communication Magazine*, Vol. 36, no. 9, pp 70-80.
- Frodigh M. 1995, "Reuse Partitioning combined with traffic adaptive channel assignment for highway microcellular radio systems", *Proc. of IEEE GLOBECOM '92*, pp 1414-1418.
- Furukawa H. and Akaiwa Y. 1993, "Self organized reuse partitioning: a dynamic channel allocation method", *Proc. of Vehicular Technology Conference VTC '93*, pp 524-527.
- Halpern S.W. 1983, "Reuse Partitioning in cellular systems", *Proc. of Vehicular Technology Conference VTC '83*, pp 322-327.

Kanai T. 1992, "Autonomous reuse partitioning in cellular systems", *Proc. of Vehicular Technology Conference VTC '92*, pp 782-785.

Kouvatsos D.D. and Xenios N.P. 1989, "MEM for Arbitrary Queueing Networks with Multiple General Servers and Repetitive-Service Blocking", *Performance Evaluation*, Vol. 10, pp 169-195.

Kouvatsos D.D. 1994, "Entropy Maximisation and Queueing Network Models", *Annals of Operation Research*, Vol. 48, pp 63-126.

Mouly M. and Pautet M.-B, "The GSM System for Mobile Communications", **Palaiseau, France**

Nokia 2002, "Nokia Telecommunications Web Site", **www.nokia.com**.

Papavassiliou S., Tassioulas L. and Tandon P. 1994, "Meeting QoS requirements in a cellular network with reuse partitioning", *Proc. of IEEE INFOCOM*, pp 1a.1.1-1a.1.9.

Pattavina A., Quadri S. and Trecordi V. 1999, "Reuse Partitioning in cellular networks with dynamic channel allocation", *Wireless Networks*, 5, pp 299-309.

Veran M. and Potier D. 1985, "QNAP-2: A Portable Environment for Queueing Network Modelling Techniques and Tools for Performance Analysis", (ed. D. Potier), *North Holland*, pp 25-63.

Zander J. and Frodigh M. 1992, "Capacity Allocation and Channel Assignment in cellular radio systems using reuse partitioning", *Electronics Letters* 28, 5, pp 438-440

Biographies



Demetres Kouvatsos received a BSc degree in Mathematics, Athens National University (1970), a MSc degree in Statistics, Victoria University of Manchester (1971) and a PhD degree in Computation, UMIST, University of Manchester (1974). He has a chair in Computer and Communication Systems Modelling and is the Head of the School of Computing and Mathematics, University of Bradford.

Professor Kouvatsos has pioneered new and cost-effective methodologies for the approximate analysis of arbitrary queueing network models (QNMs) for the performance evaluation and engineering of computer and telecommunication systems. He has directed several EPSRC (UK) and industrial research projects and is the author or co-author of many papers as well as the editor of research books and special journal issues in the performance modelling field. His latest technical interests include traffic modelling and characterisation, analytic methodologies for discrete time QNMs and performance modelling and evaluation of high speed switch architectures and the Internet.

He acted as the Chairman of seven International Federation of Information Processing (IFIP) Working Conferences on the Performance Modelling and Evaluation of ATM & IP Networks (1993-98, 2000) and as the Co-Chairman of the 3rd and 4th International Workshops in "Queueing Networks with Finite Capacity" (1995, 2000). He also served as the Technical Track Chairman of the "Analytical and Numerical Modelling Techniques" Conference of ESM '98 and as a member of many Programme Committees of international events in the field. His professional association include memberships with the IFIP Working Group WG 6.3 on the Performance of Computer Networks and the UK Performance Engineering Specialist Group of BCS and a Fellowship with the Royal Statistical Society, UK. He is also an elected member of the EPSRC College and the recipient of the IFIP Silver Core Award in recognition of his academic services to IFIP.



Irfan Awan received his PhD from the Department of Computing, Bradford University, UK (1997). During his PhD studies, he developed cost effective approximate analytical tools for the performance evaluation of complex queueing networks. His research mainly focused on service and space priorities in order to

provide quality of service and to control the congestion in high speed networks. After completing his PhD he joined GIK Institute of Engineering Sciences and Technology, Pakistan as an assistant professor and has been teaching various subjects related to network communications for two years. In 1998 and 1999, he spent summer terms with the Performance Modelling Group, University of Bradford. In 1999 he joined the Department of Computing, University of Bradford as a Lecturer and is a module coordinator for "Concurrent and Distributed Systems" and "Intelligent Network Agents". His recent research lies in developing analytical tools for the performance modelling of mobile and high speed networks.



Khalid Al-Begain received his High Diploma (1986), the Specialization Diploma of Communication Engineering (1988) and his Ph.D. degree in Communication Engineering (1989) from the Technical University of Budapest in Hungary. From 1990, he held the position of a Assistant Professor at the Department of Computer Science of the Mu'tah University/Jordan. In 1996, he became an Associate Professor at the same university. In 1997 he moved to the Department of Computer Science at the University of Erlangen-Nuremberg in Germany as Alexander von Humboldt research fellow and, furthermore, he spent one year as Guest Professor at the Chair of Telecommunications, Dresden University of Technology, Germany. Since Sept. 2000, he has been Senior Lecturer and Director of Postgraduate Research in the Department of Computing of the University of Bradford, UK. He co-authored the book "Practical Performance Modelling" published by Kluwer Academic Publishers and more than 60 journal and conferences papers. He is senior member of the IEEE and many other scientific organisations. He also serves as Guest Editor for the special issue of this journal on Analytical and Stochastic Modelling Techniques and as Conference Chair for the ASMT'03 to be held in Nottingham, UK in June 2003. His research interests are performance modelling and analysis of computer and communication systems, analytical modelling and design of wireless mobile networks.



Sotirios Tantos received in 1999 the BSc degree in Mathematics from the Aristotle University of Thessaloniki, Greece, and in 2001 the MSc Degree in Computing with distinction from the University of Bradford, UK. He is currently a PhD student in the area of Performance Modelling and Engineering at the University of Bradford and a member of the IEEE society.