

bradscholars

Synthetic, Spectroscopic and Computational Studies of Aromatic Compounds. Structure, Fragmentation and Novel Dimerisation of Indoles under Electrospray Conditions, and Innovative Nitrogen to Carbon Rearrangement of Orthogonally Protected Sulphonamides and Related Compounds

Item Type	Thesis
Authors	Saidykhan, Amie
Rights	<p>http://creativecommons.org/licenses/by-nc-nd/3.0/>
The University of Bradford theses are licenced under a http://creativecommons.org/licenses/by-nc-nd/3.0/>Creative Commons Licence.</p>
Download date	2026-04-20 03:36:37
Link to Item	http://hdl.handle.net/10454/14428



University of Bradford eThesis

This thesis is hosted in [Bradford Scholars](#) – The University of Bradford Open Access repository. Visit the repository for full metadata or to contact the repository team



© University of Bradford. This work is licenced for reuse under a [Creative Commons Licence](#).

**SYNTHETIC, SPECTROSCOPIC AND
COMPUTATIONAL STUDIES FOR
AROMATIC COMPOUNDS**

A. SAIDYKHAN

PhD

UNIVERSITY OF BRADFORD

2015

Synthetic, Spectroscopic and Computational Studies of Aromatic Compounds

Structure, Fragmentation and Novel Dimerisation of
Indoles under Electrospray Conditions, and Innovative
Nitrogen to Carbon Rearrangement of Orthogonally
Protected Sulphonamides and Related Compounds

A. SAIDYKHAN B.Sc (Hons), MChem.

Submitted for the degree of Doctor of Philosophy
Division of Chemical and Forensic Sciences

University of Bradford

2015

A. SAIDYKHAN

**SYNTHETIC, SPECTROSCOPIC AND COMPUTATIONAL STUDIES
FOR AROMATIC COMPOUNDS**

ABSTRACT

Keywords: Indoles; Tetrahydrocarbazoles; Mass Spectrometry; Vibrational Spectroscopy; Dimerisation; Electrospray; Fragmentation; Rearrangement; Sulphonamides.

The complementary value of vibrational spectroscopy and mass spectrometry in obtaining structural information on a range of tricyclic indoles with various ring patterns has been investigated, focusing particularly on whether these heterocycles with a functional group containing oxygen in the third ring should be described as ketoindoles or hydroxindolenines. Parallels between certain fragmentations of ionised indoles and electrophilic substitution in solution have been identified.

A mechanistically interesting and analytically useful interesting dimerisation, leading to the formation of $[2M-H]^+$ ions, has been discovered in the positive ion electrospray mass spectra of 3-alkylindoles. This dimerisation, which occurs in the nebuliser of the instrument, offers a potential new route to bisindoles under milder conditions than those employed in classical solution chemistry. Facile formation of C=N bonds by condensation of C=O and H₂N has been shown to provide a means of preparing protonated imines and protonated quinoxalines from mixtures of the requisite (di)carbonyl compounds and (di)amines, thus further illustrating how organic synthesis is possible in the droplets in the nebuliser of the instrument.

Possible metal catalysed coupling reaction routes to bisindoles have been explored. Acyl transfer reactions from nitrogen to carbon have been investigated in 1-acyl-2-methylindoles and orthogonally protected sulphonamides. These processes have been shown to be intermolecular and intramolecular, respectively. The latter rearrangement, which may be prevented when necessary by choosing the nitrophenylsulphonamide protecting group, offers a route to acyl, carboalkoxy and carboaryloxy aromatic compounds, some of which are difficult to prepare.

DEDICATION

For my beloved grand mother and uncle

ACKNOWLEDGEMENTS

I wish to acknowledge my gratitude to the Swedish funding body (CSN) as an undergraduate and in the first year of my postgraduate studies. It is natural for me to thank Mrs Adebayo who first introduced me to chemistry and encouraged me to take up this subject in earnest. I am indebted to Professor Howell G M Edwards and Dr Derek J Maitland, respectively, for showing me how powerful vibrational spectroscopy and nuclear magnetic spectroscopy can be in elucidating the structures of compounds. I wish to record my gratitude to Dr Richard D Bowen and Dr William H C Martin, who emphasised the elegance of this aspect of the subject, illustrated by their own approach to laboratory work and who supervised me in my Stage 3 and Stage 4 undergraduate projects. Their influence gave me the confidence to stretch myself by undertaking more challenging reactions in the laboratory.

A large number of persons at the University of Bradford have helped me in the day-to-day running of this research project. Mr Dennis Farwell and Mr Andrew Healey have provided technical advice and assistance in recording nuclear magnetic resonance, Raman and mass spectra. Other members of the technical staff have been helpful in many ways: Mr Nigel Templeton has assisted me on numerous occasions, as has Mr Alan Hague, Mr Graeme Dean and Mrs Tracey Holmes. Staff in the Stores have dealt in an efficient and friendly manner with my many enquires. I am grateful to Ms Anne T Costigan for training me in the use of Library Facilities and various forms of software which I have found extremely useful. Dr Tariq Mahmood, who was one of my predecessors as a research student in M2 laboratory, has been a pillar of strength, offering me advice on a huge range of activities. I have benefited from interacting with undergraduate project students, some of whom have contributed in a general way to the projects in which I have been involved; thus, thanks are also due to Stephen T Ayrton, Louise Williamson, Zia Bashir, Evelyne Rushingwa, Hadijatou K Touray, Jenessa Ebert and Hashim Ally who did valuable exploratory work on the some of the projects. Thanks is also due to Dr John Kendrick for doing the computational work of this research. Outside the University of Bradford, I am most grateful to Dr Richard T Gallagher of AstraZeneca, whose long-term collaboration with Dr Bowen meant that I have had a wonderful opportunity to interact with an experienced mass spectroscopist in a commercial organisation. He has effectively acted as a third supervisor.

I am grateful to my parents and the rest of my family for their support both financially and emotionally. I am eager to demonstrate by this thesis that I appreciate their support and wish them to understand how much they mean to me. I will also like to thank my friends for their continual interest in me and in my activities.

ABBREVIATIONS

aq	Aqueous
Bn	Benzyl
CI	Chemical ionisation
CID	Collision induced dissociation
Cul	Cuprous iodide
Cy	Cyclohexyl
δ	Chemical shift (NMR)
DMA	Dimethylamine
DMAP	4- <i>N,N</i> -dimethylaminopyridine
DMF	<i>N,N</i> -dimethylformamide
ee	Enantiomeric excess
eV	electron volt
EI	Electron impact
ESI	Electrospray ionisation
Et	Ethyl
OEt	Ethoxyl
FT	Fourier transform (IR and Raman)
hr	Hour
HPLC	High performance liquid chromatography
HRMS	High resolution mass spectroscopy
INC	Ion neutral complex
IR	Infra-red
<i>J</i>	Coupling constant
LC-MS	Liquid chromatography–mass spectrometry
LDA	Lithium diisopropylamine
LiAlH ₄	Lithium aluminium hydride
LiHMDS	Lithium hexamethyldisilazide
MgSO ₄	Magnesium Sulphate
MHz	MegaHertz
min	Minute
mp	Melting point
OMe	Methoxyl
Me	Methyl
NMR	Nuclear magnetic resonance
PBDs	proton bound dimers
py	Pyridine
RT	Room temperature
sat.	Saturated
NaHCO ₃	Sodium bicarbonate
SOCl ₂	Thionyl chloride
TFA	Trifluoroacetic acid
THF	Tetrahydrofuran
TLC	Thin layer chromatography
TMS	Trimethylsilyl
Ts	Tosyl
ν	Stretching frequency (cm ⁻¹)
V	Voltage

TABLE OF CONTENTS

ABSTRACT.....	i
DEDICATION.....	ii
ACKNOWLEDGEMENTS	iii
ABBREVIATIONS	iv
1. INTRODUCTION.....	1
1.1. Background.....	1
1.1.1. Molecular structure of Indole and Indolenine.....	2
1.1.2. Reactivity of Indole	3
1.1.2. Occurrence of Indoles and related Compounds	6
1.3.1. Model Compounds	10
1.4. Summary of Earlier Research.....	12
1.4.1. Mass Spectrometry of Indoles.....	12
1.5. Aim and Hypothesis.....	22
2. SYNTHESIS OF INDOLES	25
2.1. The Fischer Indole Synthesis	26
2.1.1. Overview, Scope and Limitations of the Process	26
2.1.2. The Mechanism of the Fischer Indole Synthesis	27
2.1.3. Regiochemistry of Indolisation.....	29
2.1.4. Experimental aspects of the Fischer Indole Synthesis	30
2.2. Synthesis of Indoles.....	31
2.2.1. Synthesis of Unlabelled Tricyclic Indoles	31
2.1.3. Synthesis of 1-, 2- and 3-oxocyclohexan[<i>b</i>]indoles	40
2.3. Synthesis of Deuterium Labelled Indoles	42
2.3.1. Unfunctionalised Tricyclic Indoles	42
2.3.1. Method 1: Fischer Indole Synthesis.....	42
2.3.2. Method 2: Oxidation of Unfunctionalised Tricyclic Indoles followed by Reduction	47
2.4. Conclusion.....	49
3.0. MASS AND VIBRATIONAL SPECTRA OF TRICYCLIC INDOLES.....	50
3.1. Introduction.....	50
3.2. Mass Spectra of Tricyclic and Tetracyclic Indoles	51
3.2.1. EI spectra of Tricyclic Indoles.....	51
3.3. Vibrational spectra of Tricyclic Indoles.....	67
3.3.1. Infrared and Raman Spectra of <i>n</i> -oxocycloalkan[<i>b</i>]indoles	67
3.3.2. Infrared and Raman of 1-, 2- and 3-oxocyclohexan[<i>b</i>]indoles	78
3.3.3. Infrared and Raman of <i>n</i> -cycloalkan[<i>b</i>]indoles	82

3.4. Conclusion.....	91
4.0. FORMATION OF COVALENTLY BOUND DIMERS FROM INDOLES IN THE POSITIVE ION ELECTROSPRAY MASS SPECTROMETRY	93
4.1. Background	93
4.2. Experimental.....	96
4.3. Results and Discussion	97
.....	98
4.3.1. Structure of the Dimeric Species	99
4.3.2. Scope of the Reaction	102
4.3.3. Origin of $[2M-H]^+$ Signal.....	106
4.3.4. Mechanism of Formation of the Dimer.....	107
4.4. Conclusion.....	114
5.0. ACCELERATED FORMATION OF C=N IN POSITIVE ION ELECTROSPRAY SPECTROMETRY	116
5.1. Background	116
5.2. Experimental.....	116
5.3. Results and Discussion	116
5.3.1. Formation of Imines under Positive ESI Conditions.....	116
5.3.2. Formation of Quinoxalines under positive Electrospray conditions	119
5.6. Conclusion.....	125
6. SYNTHESIS OF 1,1'-BISINDOLES	127
6.1. Background	127
6.2. Synthetic strategy.....	129
6.2.1. Synthesis of 2-bromo substituted Ketone	131
6.2.2. Synthesis of the requisite Azines.....	133
6.2.3. Copper mediated <i>N</i> -Arylation	135
6.3. Conclusion.....	137
7. BASE MEDIATED REARRANGEMENT OF 1-ACYLATED 2-METHYLINDOLES.....	138
7.1. Background	138
7.2. Results.....	140
7.2.1. Preparation <i>N</i> -protected 2-methylindoles	140
7.2.2. Rearrangement.....	141
7.2.3. Attempts to optimise the Base	144
8. NOVEL REARRANGEMENT OF SULPHONAMIDES	148
8.1. Introduction.....	148
8.2. Background	150

8.1.1. The Chan Rearrangement	150
8.1.2. Asymmetric Alkylation of α -Amino Acids	152
8.2. Aim	155
8.3. Results and Discussion	155
8.3.1. The Mechanism of the Rearrangement	161
8.3.2. The Scope of the Reaction	162
8.3.2.3. Formation of Sulphonamides Derivatives from <i>Tert</i> -butyl Aniline	172
8.4. Conclusion.....	176
9. CONCLUSIONS AND SUGGESTIONS FOR FURTHER WORK	179
10. EXPERIMENTAL	184
10.1. General comments	184
10.2. Synthesis.....	186
10.2.1 General procedure for the synthesis of Tricyclic Indoles	186
10.2.2. General procedure for the synthesis of Tetradeuteriocycloalkanones.....	189
10.2.3. DDQ Oxidation: General procedure.....	192
10.2.4. Synthesis of 2-(2-bromophenyl)-1-phenyl-1-ethanone azine, 125	194
10.2.5. 3-Methyl-2-(pyridine-2-sulphonylamino)-butyric acid <i>tert</i> butyl ester, 167	195
10.2.6. <i>N-tert</i> butylcarbamate, 168	196
10.2.7. Rearrangement of <i>N-tert</i> butylcarbamate, 170	197
10.2.8. General Synthesis of <i>N</i> -acylated compounds.....	198
10.2.9. General procedure for the rearrangement	202
10.2.10. General Procedure for Synthesis of Sulphonamides	206
10.2.11. General procedure for 'Boc' protection	209
10.2.12. General synthesis of <i>N</i> -acylated compounds	211
10.2.13. General procedure for the rearrangement reaction	216
10.2.14. General procedure Sulphonamide derived from <i>Tert</i> butyl Aniline	221
10.2.15. General procedure for preparing Carbamates derived from <i>Tert</i> butyl Aniline.....	225
10.2.16. General procedure for synthesis of the Rearranged Product	228
11. References.....	232
12. LIST OF PUBLISHED PAPERS AND CONFERENCE PRESENTATIONS	269

1. INTRODUCTION

1.1. Background

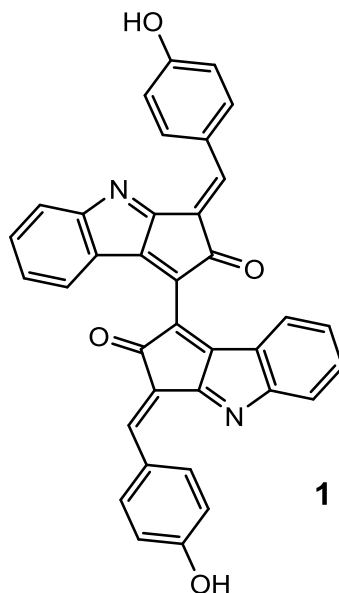

The multidisciplinary research described in this thesis arose from the discovery that the octacyclic compound, scytonemin, **1**, is produced by extremophiles, apparently as a means of providing protection against the harmful effects of ultraviolet radiation in harsh terrestrial environments.^{1, 2} Since scytonemin appears to have enormous potential as a biomarker for extant and extinct life,^{1, 3-11} both on Earth and perhaps elsewhere in the Solar System, the development of spectroscopic protocols for detecting it and related compounds is clearly of fundamental significance in the search for extraterrestrial life. However, scytonemin itself is a large molecule, which would be expected to exhibit complex spectra that might be difficult to obtain and interpret. Consequently, it was logical to initiate this investigation by devising and studying simpler model compounds that contain the key features of the heterocyclic nuclei in scytonemin. Tricyclic species comprising a benzenoid ring fused to a five membered ring containing a nitrogen atom,

with a third rings attached to the heterocyclic ring were obvious candidates for suitable model compounds see Figure (1) below. This preliminary conclusion is reinforced by the fact that the relevant bicyclic compound, indole, **2**, derived by fusing a benzene ring to a five membered ring nitrogen heterocycle is one of the most important compounds in the natural world. Indoles are widely distributed in the form of alkaloids, including strychnine,¹² **3**, the first indole alkaloid to be identified and to have its structure elucidated.¹³ Other important examples of the occurrence of the indole nucleus in living systems include the amino acid tryptophan, **4**, and 5-hydroxytryptamine (**5**, a monoamine alkaloid that is believed to play an important role as a neurotransmitter in the brain).¹⁴

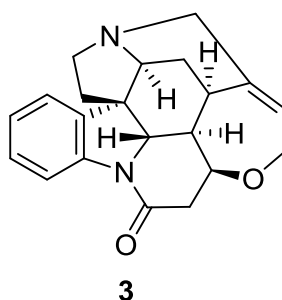

1.1.1. Molecular structure of Indole and Indolenine

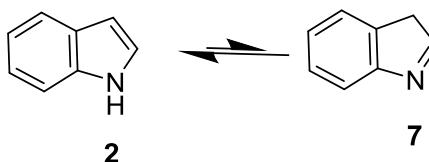

Indole was first isolated in 1866 from the reduction using zinc dust of oxindole which was in turn obtained as one of the two products from the reduction of isatin, **6**.^{15, 16} The structure that has long been accepted for indole consists of a benzene ring fused to a pyrrole ring, with the two rings

sharing a carbon-carbon linkage that is usually depicted as a double bond. It is an aromatic system, with 5 pairs of π -electrons; 4 pairs from the double bonds and 1 pair of electrons from the nitrogen lone pair. Indole has one interesting and important tautomer, indolenine, **7**, in which there is a C=N bond in the heterocyclic ring, which is not aromatic (in contrast to indole itself). The greater aromatic character of indole, in which both rings are aromatic, is reflected in its greater stability compared to indolenine, and the position of the tautomeric equilibrium (which strongly favours indole). As a result, indoles are widespread in nature, whereas indolenines are much less common (it is, therefore, interesting that the two heterocyclic entities in scytonemin have the C=N double bond in the heterocyclic ring).

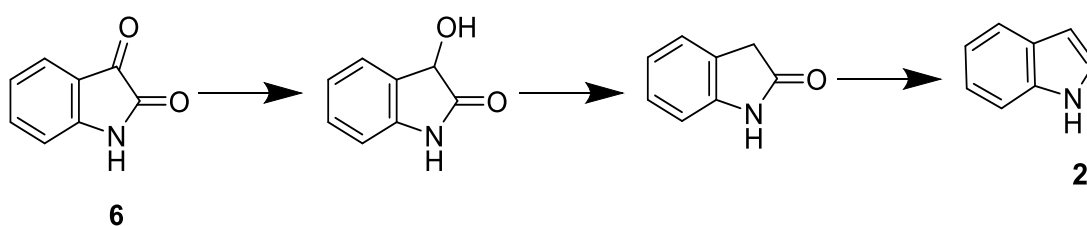

Scheme (1)

1.1.2 Reactivity of Indole

The characteristic reaction of aromatic compounds is electrophilic substitution,^{17 18, 19} which may be described in mechanistic terms as a two-step process, involving an intermediate arenium ion, in which the first step is usually rate-determining.¹⁷ In bicyclic systems such as Indole, the electrophile may become attached to an atom in either ring.²⁰ The relative electron density in each ring, and at each atom in the more electron rich ring, normally controls the position at which the electrophile first becomes

attached, thereby determining the nature of the substituted product. The electron density at the carbon atoms in the parent monocyclic heterocycle, pyrrole, **8**, is greater than that in benzene; in addition, the resonance energy of pyrrole is much less than that of benzene. These two factors influence the relative reactivity of benzene and pyrrole in electrophilic substitution; pyrrole reacts perhaps as much as 10^8 - 10^{10} times faster than benzene with a given electrophile. Therefore, indole undergoes electrophilic substitution in the heterocyclic ring, rather than in the carbocyclic ring, which may be considered to be relatively unreactive. Hence, halogenation,²¹ Friedel-Crafts acylation and alkylation,^{22, 23} and other electrophilic substitutions of indole and its derivatives almost always occur in the heterocyclic ring.²⁴

Although the same factors, including the effect of the lone pair of electrons on nitrogen in activating the heterocyclic ring, may be considered to operate in indole as in the pyrrole, these two heterocycles do not undergo electrophilic substitution of at the same position in the five membered ring. The electrophile normally becomes attached to the 2-position in pyrrole, whereas attack at the 3-position of indole occurs instead.²⁵ This contrast, which is at first sight surprising, can be explained in two distinct ways.

Firstly, analysis of the stability of the intermediate arenium ion reveals that attachment of the electrophile to the 3-position does not disturb the aromaticity of the carbocyclic ring, Scheme (**2**), but rather merely disrupts that of the heterocyclic ring, in which the resonance energy is in any case less than that of the carbocyclic ring. This effect overrides the situation for pyrrole, in which electrophilic attack at the 2-position forms an arenium ion in

which there is an extra canonical form that is not available if the reaction occurred at the 3-position, Scheme (3).

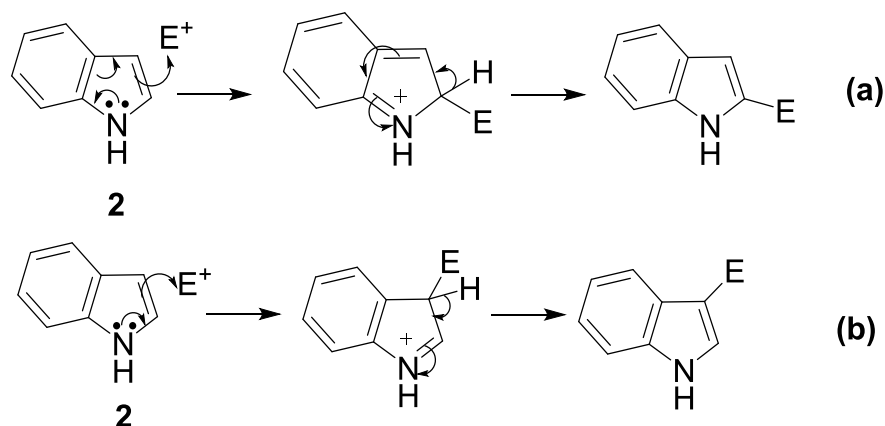

Scheme (2): Mechanism proposed for the electrophilic substitution of indole; **a)** attack at the 2-position; **b)** attack at the 3-position.

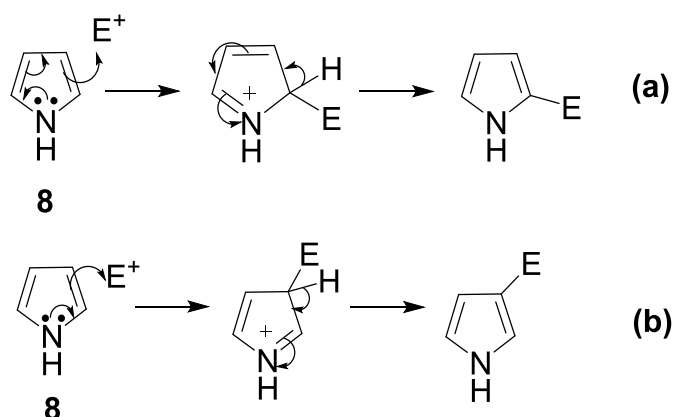

Scheme (3): Proposed mechanism for the electrophilic substitution of pyrrole; **a)** attack at the 3-position; **b)** attack at the 2-position.

An alternative explanation, which is more profound in so far as it addresses the initial interaction between the aromatic compound and the electrophile, is to consider the electron density in the highest occupied molecular orbital (HOMO) in the set of π -orbitals. In the case of pyrrole, the coefficient on the 2- and the 3-positions is 0.600 and 0.371, respectively. On the other hand, in indole, the corresponding coefficients are 0.219 and

0.595,²⁶ respectively. A larger numerical value corresponds to a greater electron density, which increases the probability of the electrophile becoming attached to the relevant position.²⁶

1.1.2. Occurrence of Indoles and related Compounds

The bicyclic indole nucleus provides the skeleton for numerous biologically active molecules such as indole alkaloids,²⁷⁻³³ plant-growth regulators³⁴⁻³⁶ and a wide range of pharmaceutical compounds.³⁷⁻⁴¹ The occurrence and utility of some illustrative examples in these disciplines is briefly reviewed in this section.

1.1.2.1. Indole Acetic Acid (IAA)

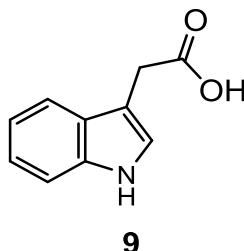

Indole acetic acid, **9**, which was discovered in 1933,³⁵ is the most important auxin (plant growth hormone) that is widely distributed in monocots, dicots, vascular plants (gymnosperms and ferns).^{15, 34} The related indole derivatives, indoleacetaldehyde and indoleacetonitrile, also are plant growth hormones. Indole acetic acid consists of an indole nucleus with a simple monofunctional side chain attached to the 3-position. It influences almost all the aspects of plant growth, including the development of the embryo, the inhibition of bud growth, the maturation of flowers into fruits, and

the induction of cell division.⁴² The action of indole acetic acid is inhibited by many synthetic compounds generally called anti auxins.

1.1.2.2. Tryptophan and Serotonin

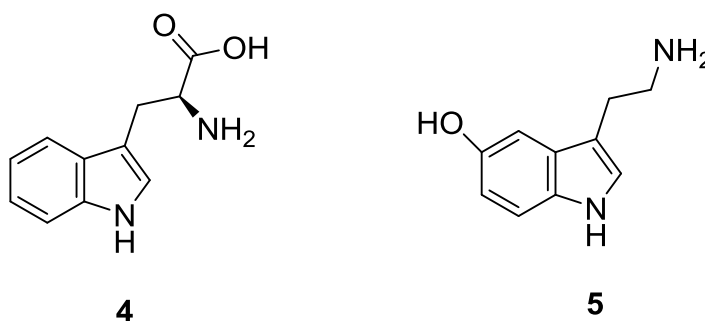

As with indole acetic acid, Tryptophan, **4** and 5-hydroxytryptamine, **5**, both contain the indole nucleus with a side chain at the 3-position. These compounds are vital to life: tryptophan is an essential amino acid⁴³ and 5-hydroxytryptamine commonly known as serotonin is a neurotransmitter involved in the transmission of nerve impulses.⁴⁴ Tryptophan is obtained from plant and animal sources⁴⁵ such as cheese, turkey, banana, nuts and other protein rich foods.⁴⁶ It is a protein building block and it the precursor of niacin^{47 48}(vitamin B₃), melatonin⁴⁹⁻⁵³ and 5-hydroxytryptamine.^{45, 54-59}

In the brain, 5-hydroxytryptamine is biosynthesised in two chemical steps from tryptophan;⁶⁰ hydroxylation at the 5-position of tryptophan by the enzyme tryptophan 5-hydroxylase^{55, 61} give 5-hydroxytryptophan, **10**,⁵⁶ which then decarboxylated to yield a molecule of 5-hydroxytryptamine, **5**, which is commonly known as serotonin, Scheme (4). Apart from the brain, serotonin can be found mainly in blood platelets and in the bowel Serotonin plays an important part in regulating mood,^{58, 62-65} sleep and it is a powerful vasoconstrictor^{59, 66, 67} in the blood serum and is the precursor in synthesis of melatonin (a hormone that helps control sleep).⁶⁸

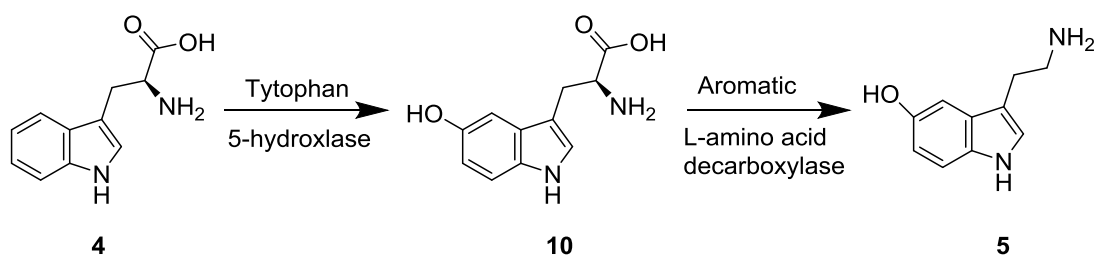

Scheme (4): Biosynthesis of serotonin

1.1.2.3. Indole Alkaloids

Indole alkaloids comprise one of the largest and most important classes of naturally occurring nitrogenous compounds. As mentioned in the introduction, strychnine is a seminal example; it was once widely applied as a poison; in addition, it was once administered to humans in trace doses on the basis that anything that tasted so awful was bound to be beneficial.^{13, 69} Fortunately, modern medicine has long since discarded such misguided notions.

Many indole alkaloids do not contain an intact indole nucleus. However, they are obviously derived from indole by elaboration of the skeleton, often by attachment of substituents or rings to the 3-position and/or the 2-position (as is the case in strychnine itself). Many of these compounds have highly complex structures; typically with several rings (strychnine itself has six rings, seven chiral centres and at least five functional groups).

1.1.2.4. Scytonemin

Scytonemin,⁷⁰ **1**, is a yellow-brown solid⁷¹ located in the extracellular polysaccharide sheath⁷¹⁻⁷⁴ found exclusively in cyanobacteria^{71, 73, 75} (blue-

green algae). Therefore, Scytonemin can act as a biomarker only for cyanobacteria.^{70, 73, 76} The trivial name “sytonema skeleton” reflects the fact that there are 8 rings in its skeleton.^{74, 77} Its structure comprises two symmetrical monomer subunits, each consisting of an indolic and 4-hydroxybenzylidene component.⁷⁷ Since scytonemin possesses a basic nitrogen atom (in fact, it has two), it may be considered to be an alkaloid.

Scytonemin appears to play an important role as an ultraviolet (UV) protectant^{1, 75, 78, 79} especially in lower organisms exposed to high solar radiation, playing a similar role to melanin in higher animals (including humans) and phenylpropanoids in plants.^{73, 74} This pigment is synthesised upon exposure to UV A light to protect the organisms from the damaging effect of the harmful UV radiation. It has been reported that the presence of scytonemin reduces by up to 90% the proportion of incident UV radiation that reaches the cell. Scytonemin shows strong absorbance in the UV with the absorbance maxima at 385,⁷⁸ 300, 278 and 252 nm.^{71, 77} The effectiveness of this indole alkaloid as a UV protectant is mainly due to its ability to absorb in the UV A (315–400) region as well as UV B (280–315).⁷¹ Even though no direct link has so far been established between the scytonemin produced and rate of photosynthesis, the occurrence of this pigment in 300 species⁷⁰ ranging from cyanobacterial lichens (*Collema*) to terrestrial cyanobacterium *Chlorogloeopsis* sp.⁷⁷ indicates that it is essential for their survival. Cyanobacteria existed on Earth for several billion years, from well before the oxygen (and its allotrope, ozone, which is the key component of the ozone layer, which itself provides protection against certain forms of UV radiation) was present in the atmosphere. Consequently, the ability of early forms of life

to synthesise molecules such as scytonemin might have protected them against high UV radiation,⁸⁰ thus facilitating their survival and reproduction.

1.3.1. Model Compounds

1.3.1.1. Selection of Model Compounds

The process of deciding which simpler compounds would be the best models for scytonemin can be divided into three conceptual parts. Firstly, the molecular structure comprises two identical tetracyclic entities; this symmetry can be exploited by considering only one of the two subunits. Secondly, the benzylidene (ArCH=) side chain may be considered to be of secondary importance on the basis that the tricyclic heterocyclic part contains the crucial structural features. It should be noted, however, that the hydroxybenzylidene units are undoubtedly important in at least two respects: they significantly increase the extent of conjugation in the subunits; in addition, the slightly acidic nature of the phenolic hydroxyl groups may impart an advantageous solubility in alkaline environments. Thirdly, the presence of a carbonyl group in the third ring of the tricyclic subunit may or may not be required; both generic systems appear to be worth investigation. In summary, these considerations lead to the idea of investigating tricyclic indoles with varying ring patterns and the corresponding ketoindoles.

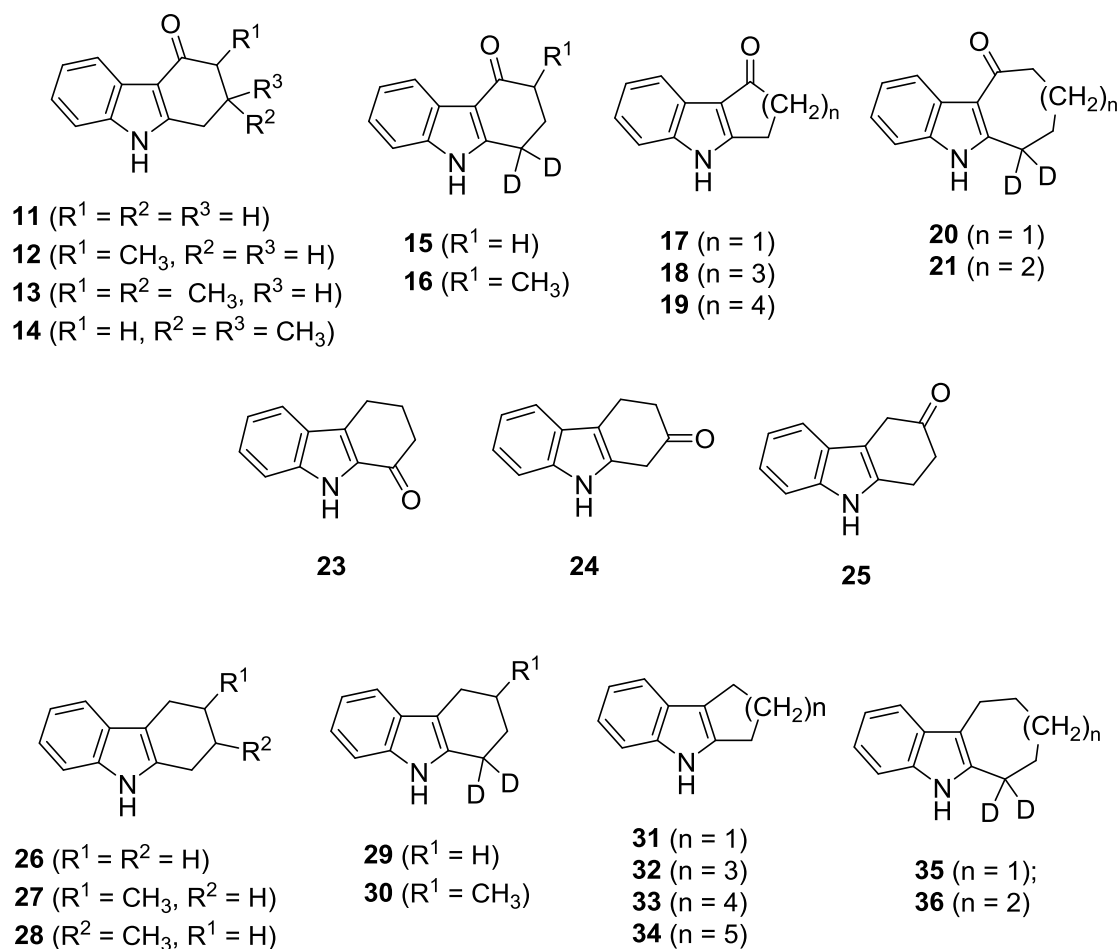

Figure (1): Model compounds

1.3.1.2. Nomenclature of Model Compounds

It is useful to use abbreviations to define the ring pattern (and, in some cases, other features) of the structure of the model compounds. For simpler bicyclic indoles, which became worthy of further investigation once certain interesting dimerisation reactions were discovered in their electrospray mass spectra, the conventional numbering system is used. Thus, in 1-methylindole, **37**, 2-methylindole, **38** and 3-methylindole, **39**, the number simply indicates the position of the methyl substituent in the indole, Figure (2).

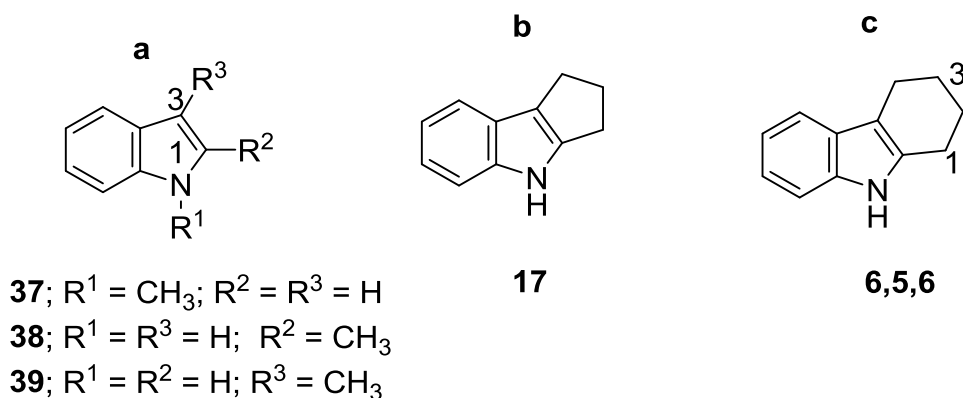

Figure (2): Structures showing the naming and numbering system; a) acyclic indoles; b) 6,5,5; c) 6,5,6.

A set of numbers (“6,5,n” and “6,5,n,m”) indicates the sizes of the fused rings in the indoles; the “6,5” part refers to the carbocyclic and heterocyclic rings, which must have six and five atoms, respectively, in any indole. Thus, for instance, the “6,5,5” system, **17**, refers to tricyclic indoles comprising an indole fused to a carbocyclic 5-membered third ring. In the case of the important “6,5,6” tricycles, which are tetrahydrocarbazoles, the numbering system is shown in Scheme (3). Many of these “6,5,6” tricycles are readily prepared, with and without a carbonyl group in the third ring, and have informative spectroscopic properties.

1.4. Summary of Earlier Research

1.4.1. Mass Spectrometry of Indoles

As is the case with many other classes of organic compounds, the use of mass spectrometry in elucidating the structure of indoles was established during the 1960s, when mass spectrometers were commercially available, thus permitting many pioneering studies to be made. Thus, the value of mass

spectrometry in analysing indole alkaloids is well-illustrated by the determination of the nature of sarpagine, **40**.⁸¹ The insight obtained by this seminal study allows the presence of a sarpagine base unit³⁰ to be recognised, typically by exploiting the “shift rule”, which can be extremely valuable when dealing with a new derivative that has common structural features with those of a parent compound which has previously been investigated. Unlike other important *N*-heterocycles, such as pyrroles, which have attracted extensive attention, relatively few studies of the mass spectra of indoles have been reported, especially in tricyclic systems. Only two significant papers on the fragmentation patterns of tricyclic indoles under Electron Ionisation (EI, formerly referred to as “Electron Impact”) appear to have been published.^{82, 83}

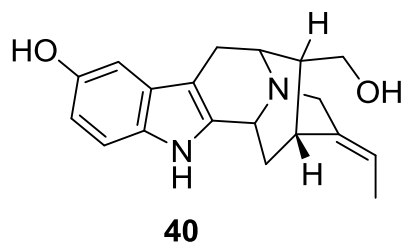

1.4.1.2. Mass Spectra of *n*-cycloalkan[*b*]indoles

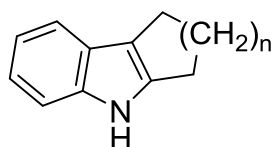

31 (*n* = 1); **26** (*n* = 2); **32** (*n* = 3); **33** (*n* = 4); **34** (*n* = 5)

One of the two published mass spectrometric studies on unsubstituted tricyclic indoles, the principal fragment ion at *m/z* 157 in the EI mass spectrum of tetrahydrocarbazole, **26**, was found to correspond to loss of

ethylene⁸⁴ from the ionised molecule. This primary fragment ion was interpreted a retro Diels-Alder (RDA, process), resulting in the fission of the bond(s) connecting C(2) and C(3), with the formation of a very stable ion, **route a** Scheme (5).⁸²

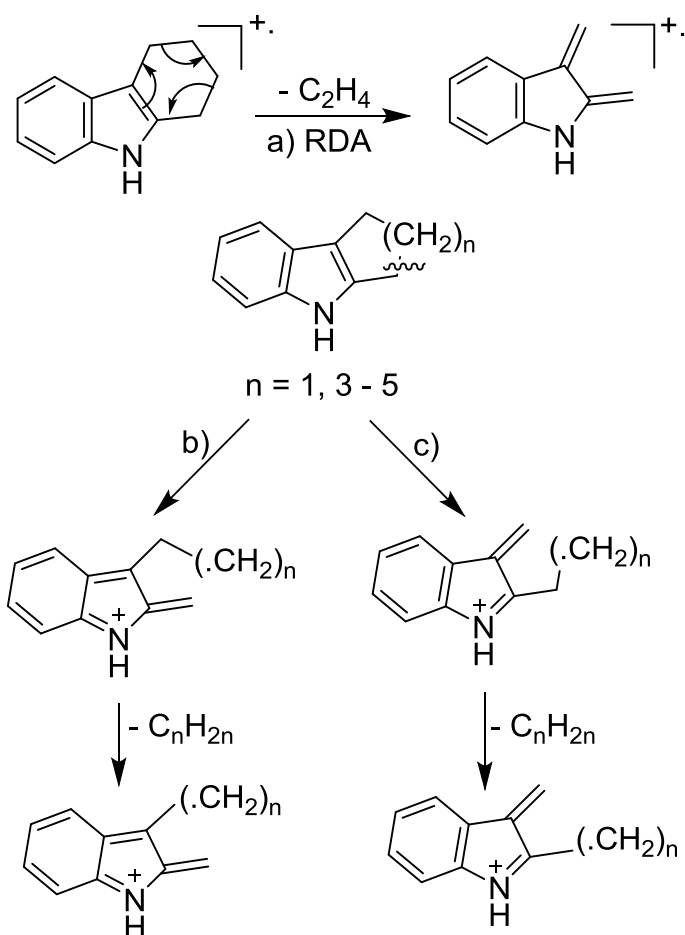

Scheme (5): Proposed mechanism for the fragmentation of **26, 31-14**.^{84, 85}

Deuterium labelling experiments were consistent with this interpretation, but it would be more accurate to refer to the process as a cycloreversion. This study was extended to encompass cycloalkan[*b*]indoles with a 5-, 7-, 8- and 9-membered⁸³ third ring; the tendency of the molecular ion derived from these “6,5,5”, **31**, “6,5,7”, **32**, “6,5,8”, **33**, and “6,5,8”, **34**, to eliminate a neutral species having the constitution C_nH_{2n} suggests strongly that this

fragmentation need not always occur with concerted cleavage of the two bonds, as is formally the case in a cycloreversion.

The base peak (that is, the most intense signal, to which the intensity of other signals in the mass spectrum are conventionally normalised) in the EI spectra of all of these tricyclic indoles, with the exception of tetrahydrocarbazole, corresponds to the molecular ion signal (M^+). This result is expected as intense M^+ peaks often appear in the spectra of aromatic compounds⁸⁶ because their extensive conjugation and cyclic nature means that dissociation is energetically less favourable than would be the case for saturated acyclic radical-cations, which frequently undergo extensive fragmentation.^{87, 88}

In contrast to the spectra of its homologues with smaller and larger third rings, the base peak in the spectrum of tetrahydrocarbazole is $[M-C_2H_4]^+$, corresponding to loss of ethylene, as has been previously reported⁸². This fragmentation may be more favourable starting from the ionised tricyclic indole **26** because it may proceed by a simple cycloreversion, whereas a two-step process, perhaps involving a relatively unstable intermediate cation, must be involved in the corresponding mechanism for eliminating ethylene from the higher homologues. It is also interesting that these higher homologues lose a larger C_nH_{2n} neutral species ($n = 3$ and 4 , respectively, from the radical-cations formed from the “6,5,7”, “6,5,8” and “6,5,9” heterocycles), as well as smaller amounts of C_2H_4 . These dissociations may be understood in terms of a unified mechanism Scheme (5), but it is not necessarily the case that an alkene is eliminated in every instance.

If these fragmentations proceed by complete cleavage of a bond connecting one of the two carbons atoms to the rest of indole entity, whilst the other remains intact, two possibilities may be considered. Route (**b**) gives a delocalised cation in which the aromatic nature of both the remaining rings is disrupted; this possibility resembles in some ways electrophilic substitution of indole by attachment of the electrophile to the 2-position of the ring, which is less favourable than the corresponding reaction in which the electrophile is attached to the 3-position. However, the alternative, route (**c**), corresponds conceptually to electrophilic substitution at the 3-position, in which the resultant cation can be delocalised without disturbing the aromatic character or the carbocyclic ring. By analogy with conventional solution chemistry, this second route would be expected to be favoured. A more detailed analysis, as presented later in Chapter 3, supports this view.

Table (1): Previously reported fragmentation patterns of *n*-cycloalkan[*b*]indoles.^{84, 85}

26		31		32		33		34		Assignment
m/z	RI	m/z	RI	m/z	RI	m/z	RI	m/z	RI	
171	55	157	100	185	100	199	100	213	100	M ⁺
170	23	156	100	184	67	198	25	212	16	[M-H] ⁺
143	100	129	14	157	37	171	32	185	24	[M-C ₂ H ₄] ⁺
				143	45	157	20	171	22	[M-C ₃ H ₆] ⁺
				129	14	143	78	157	25	[M-C ₄ H ₈] ⁺
						129	13	143	45	[M-C ₅ H ₁₀] ⁺
								129	18	[M-C ₆ H ₁₂] ⁺

In the case of the “6,5’5” system, **31**, elimination of an alkene from the third ring of ionised tricyclic indoles is not possible because there are insufficient carbon atoms in this ring to permit the formation of a stable product ion. Under these circumstances, loss of a hydrogen atom often occurs, as has been observed in this case. This interpretation was confirmed by deuterium labelling: [1,1-²H₂]-1,2,3,4-tetrahydropent[*b*]indole and [3,3-²H₂]-1,2,3,4-tetrahydropent[*b*]indole both showed intense signals for the loss of a hydrogen and a deuterium atom, thus establishing that [M-H]⁺ originates by expulsion of a hydrogen (or deuterium, in the case of the labelled species) atom from the third ring of these tricyclic indoles.

1.4.1.3. Mass Spectra of n-oxo-cycloalkan[*b*]indoles

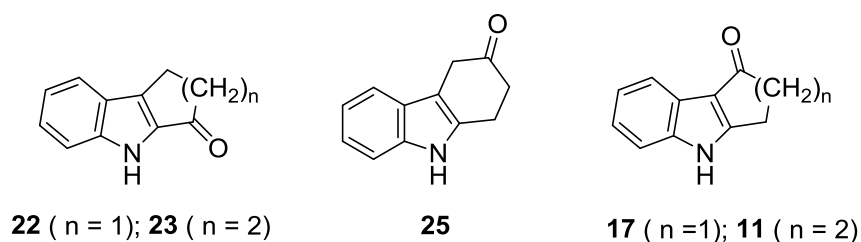

Tricyclic indoles with a carbonyl group in the third ring are obviously worthy of investigation because of their resemblance to the tricyclic core of scytonemin. As is generally the case for aromatic compounds, and as has been summarised above for the corresponding unfunctionalised tricyclic indoles, strong M⁺ signals have been reported in the mass spectra of these ketoindoles. Indeed, in many cases, the molecular ions produce the base peak. The two main fragmentations of the radical-cations derived from these ketoindoles with the carbonyl group in the 1- or 4-position are [M-28]⁺ and [M-56]⁺.⁸³ These processes are primary and secondary fragmentations,

respectively, producing fragment ions that are formed in one and two steps from the ionised molecule. The primary fragment ion could be either $[M-CO]^+$ or $[M-C_2H_4]^+$; similarly, the secondary fragment ion could be either $[M-CO-C_2H_4]^+$ or $[M-C_2H_4-CO]^+$ (assuming, as is very likely, that the species arises by consecutive loss of two different molecules, in either possible order). Accurate mass measurements at high resolution confirmed that the elemental composition of the primary fragment ion of **17** at m/z 143 was $C_{10}H_9N$. It was concluded, therefore, that CO is lost preferentially in the primary fragmentation, which may be followed by elimination of C_2H_4 . When other homologous species were subjected to mass spectrometry during the course of the research reported in Chapter **3** of this thesis, further evidence to support this view was acquired from the fragmentation of ionised tricyclic ketoindoles with one or two methyl groups in the third ring.

When the carbonyl group is in the 3-position, **25**, loss of CO followed by C_2H_4 still occurs from the ionised molecule. However, a new pathway, elimination of a neutral species with a mass of 42 amu, competes. This new fragmentation, which has been interpreted as loss of ketene ($CH_2=C=O$) via RDA, allows tetrahydrocarbazoles with a carbonyl group in the 3-position to be distinguished from their isomers with a carbonyl group in the 1 or 4 position. The new work reported in Chapter **3** confirms the generality of these conclusions, as well as extending them to include the case of tetrahydrocarbazoles with a carbonyl group in the 2 position and/or one or two methyl group(s) in the third ring.

1.4.1.4. Vibrational and Mass Spectroscopy

Any spectroscopic protocol for detecting and characterising model tricyclic indoles would be enhanced if it includes at least two different methods. In this connection, vibrational spectroscopy has many advantages that complement those of mass spectrometry (which is exceedingly sensitive, highly versatile and rapid).⁸⁹⁻⁹³ Vibrational spectroscopy is neither destructive nor invasive; Raman spectroscopy offers another advantage in so far as it arises from scattering of electromagnetic radiation from the surface of the analyte, thereby circumventing any requirement for sample preparation or transmission of the radiation through the body of the sample. In addition, vibrational spectroscopy is especially well suited to detecting important functional groups (especially N-H, C=N, C=O and C=C bonds).⁹⁴ Infrared (IR) spectroscopy is normally employed by organic chemists because it is well-suited for establishing the presence of functional groups that contain a high degree of electrical polarity; this feature of IR spectroscopy reflects the fact that vibrations that cause a change in the permanent electric dipole moment of the molecule under investigation couple efficiently with the incident radiation.⁹⁵ Since O-H and C=O bond fall into this category, IR is often employed in studying keto-enol tautomerism.⁹⁶ On the other hand, in Raman spectroscopy, efficient coupling of the incident radiation occurs when the molecular vibration causes a change in the dimensions of the polarisability ellipsoid of the molecule.^{97, 98} In general, vibrations that are strongly active in IR spectroscopy are less active in Raman spectroscopy; C=O, O-H and N-H vibrations usually fall into this category. Conversely, vibrations that are less

active in IR spectroscopy are sometimes strongly active in Raman spectroscopy (C=C vibrations are an important case in point).

If a molecule possesses a centre of symmetry (which necessarily means that it cannot have a permanent electric dipole moment), the contrast between IR and Raman spectroscopy assumes a “black and white” nature, with no shade of grey: any vibration of such a molecule that is active in the IR will be inactive in the Raman, and vice versa. This rule of mutual exclusion can be a most useful guide in comparing IR and Raman spectra of centrosymmetric molecules.⁹⁹

These considerations reveal that the vibrational spectroscopy (which is non-destructive and non-invasive)^{100, 101} is highly complementary to mass spectrometry (which is destructive, but exceptionally sensitive and easily combined with chromatographic methodology to analyse mixtures)⁸⁹⁻⁹¹. Moreover, the two main types of vibrational spectroscopy are complementary to each other, thus further enhancing the power of a spectroscopic protocol based on a combination either or both with mass spectrometry.

In early work on the preparation of tricyclic ketoindoles with a “6,5'6” ring pattern, **11**, obtained from cyclohexan-1,3-diones, it was proposed on the basis of the colour of the relevant phenylhydrazone derivative and other considerations that the carbonyl group was in the 4-position (rather than the 2-position).¹⁰² This study was performed before modern spectroscopic methods were routinely utilised by organic chemists for structure elucidation. When this early work was repeated at the outset of the current investigation, the IR spectrum of the supposed ketoindole showed neither of the expected bands at about 3330 cm^{-1} (the strongly active N-H stretch that occurs in the

spectrum of most indoles) or 1700 cm^{-1} (the strongly active C=O stretch that appears in the spectrum of practically every carbonyl compound). These preliminary observations suggested that the vibrational spectra of these heterocycles could be more interesting than might have been anticipated. Indeed, the possibility that the compounds were actually hydroxyindolenines had to be seriously considered.

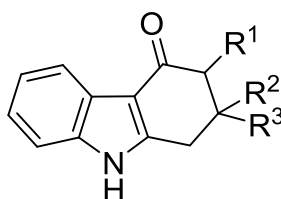

11 $R^1 = R^2 = R_3 = \text{CH}_3$; **12** $R^1 = \text{CH}_3$, $R^2 = R^3 = \text{H}$;
13 $R^1 = R^2 = \text{H}$, $R^3 = \text{CH}_3$; **14** $R^1 = \text{H}$; $R^2 = R^3 = \text{CH}_3$

A search of the requisite literature in the Cambridge crystallographic database revealed that molecular structure of 1,2-dihydrocarbazol-4(3H)-one, **11**, in the crystalline state consists of strongly associated molecular aggregates with intermolecular nitrogen-hydrogen-oxygen bridges between the NH of the indole and the carbonyl groups in the anti-form.^{103, 104} This finding is consistent with the conclusions reached many years ago on the basis of evidence that might now be considered rather speculative.¹⁰² Nevertheless, a more detailed analysis of various spectroscopic data, as presented in Chapter **3** of this thesis, indicates that these ketoindoles are not typical of compounds containing an indole N-H and a C=O functional group, particularly in the solid state. Considerable care is needed in interpreting their IR spectra, which could easily confuse an unwary interpreter.

1.5. Aim and Hypothesis

The initial objective of the research presented in this thesis was to examine the potential of tricyclic indoles as model compounds for establishing a spectroscopic protocol for detecting the presence of potential biomarkers for extant and extinct life. It was envisaged that a combination of mass spectrometry and vibrational spectroscopy, both of which can be done with miniaturised instrumentation capable of being deployed remotely in extreme environments on Earth and elsewhere, would form the basis of the analytical techniques in this approach.

In order to maximise the power of such an approach, it was necessary to study in more detail the mass and vibrational spectra of the chosen model compounds. Several ionisation methods, particularly electrospray (ESI), which is readily combined with chromatographic methods to permit the direct analysis of mixtures, have been devised and applied since the earlier studies of the EI mass spectra of tricyclic indoles were reported.^{82, 83} Consequently, one aspect of the mass spectrometric part of the proposed investigation was to extend the range of ionisation methods that have been applied in studying heterocycles of this general structure. In addition, the fragmentation of the relevant M^+ radical-cations (formed under EI conditions) and MH^+ ions (generated by ESI) should be investigated in more detail, ideally by studying the behaviour of deuterium labelled analogues. The required labelled tricyclic indoles could be prepared by a variety of routes, including subjecting cycloalkanones to exchange of the protium (H) atoms on the α -carbon atoms with D_2O (deuterium, D, oxide, alias “heavy water”, which is the cheapest source of deuterium). The resultant deuteriated ketones could then be

elaborated by the Fischer indole synthesis to produce tricyclic model compounds with a CD₂ group. Another option would be to reduce with LiAlD₄ the *n*-oxocycloalkan[*b*]indole to give deuterium labelled tricyclic indoles. These labelled species would also serve as internal calibrants (“spikes”) in further investigations designed to establish the detection limits for the unlabelled compounds alone or in admixture with other materials. Determining the threshold above which it would be possible to detect and characterise the model compounds would obviously be important in devising a robust spectroscopic protocol.

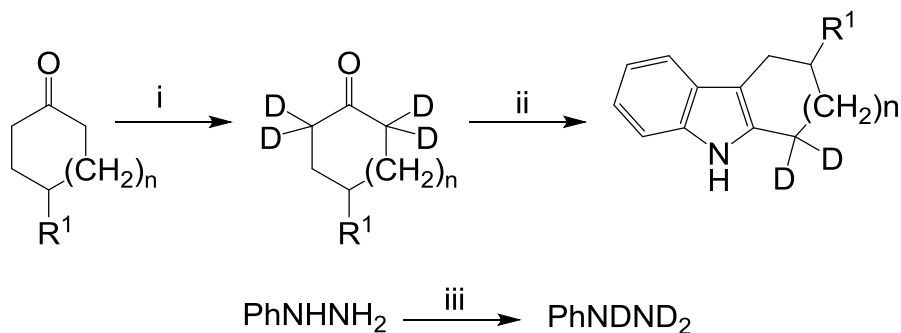

Scheme (6) *Reagents and conditions*: i) D₂O, NaOD, PhCH₂N(C₂H₅)₃⁺Cl⁻; repeat twice; ii) PhNDND₂, CD₃CO₂D, Δ; iii) D₂O, repeat twice

The secondary objective was to study in greater depth the vibrational spectroscopy of suitable tricyclic indoles with a carbonyl functional group in the 4-position, in order to ascertain whether these heterocycles really are ketoindoles. As indicated above, a cursory inspection of the IR spectrum of “4-oxotetrahydrocarbazole” suggests that this compound may actually be the corresponding indolenine, at least in the solid state. A range of tricyclic indoles with various ring patterns (not only “6,5,6”, but “6,5,7”, “6,5,8” and, if possible, “6,5,5”, which bears the strongest resemblance to the

tricyclic core of scytonemin) with and without a carbonyl group in the third ring will be prepared for investigation by mass spectrometry. It would be logical to study their vibrational spectra in detail whilst seeking to devise the spectroscopic protocol for detecting these species. Furthermore, establishing whether these species exist predominantly or exclusively as the “carbonyl” (ketoindole) or “enol” (hydroxyindolenine) tautomer would be an integral part of this aspect of the investigation. It would also be of intrinsic interest because indolenines are normally much less stable than indoles.

These and related considerations indicated that the starting point for the project should be to prepare and investigate a range of tricyclic indoles by a combination of mass spectrometry and vibrational spectroscopy.

2. SYNTHESIS OF INDOLES

Since the discovery of indole, a wide variety of classical techniques have been developed.¹⁰⁵⁻¹⁰⁹ The suitability of a specific method is dictated by several factors including functional group tolerance and availability of the starting materials. Reissert,^{110, 111} Madelung,¹⁰⁷ Bartoli,^{109, 112} Gassman,¹¹³ Heck coupling,¹⁰⁸ Mori Ban^{114, 115} and Fischer indole methods^{116, 117} are examples of methods for synthesising indoles.

The Reissert indole method involved the base-catalysed condensation of *o*-nitrotoulene, **41**, with diethyl oxalate **42** in the presence of NaOEt, Scheme (7).¹¹⁸ This is followed by hydrolysis of the ester functional group to give the corresponding acid, **43**, and the reduction of the nitro moiety with zinc in acetic acid to give the amino functionality, *o*-aminophenylpyruvic acid, **44**. This reduction step can be effected by a variety of reagents including Zn/AcOH, Zn/AcOH/Co(NO₂)₂, Zn-Hg/HCl, Fe/HCl, Fe/HOAc or Na₂S₂O₄.¹¹¹ This is followed by nucleophilic attack of the amino group on the electrophilic carbonyl group to furnish the cyclized intermediate, **45**. The final step involves the decarboxylation to give the desired indole, **2**.

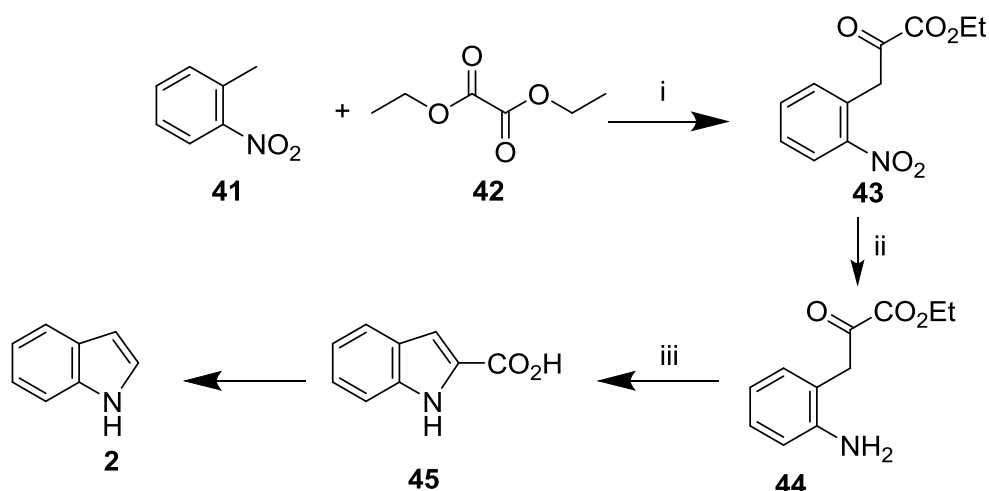

Scheme (7): Reissert indole synthesis

2.1. The Fischer Indole Synthesis

2.1.1 Overview, Scope and Limitations of the Process

Amongst the wide range of methods available, the Fischer method was employed to synthesise the model compounds. This method involves the preliminary condensation of a carbonyl compound (usually a ketone, but occasionally an aldehyde) with an arylhydrazine to form an arylhydrazone, which is then rearranged to give the desired indole in a step that is often described as “indolisation”. The overall process may, therefore, be regarded as occurring in two stages, namely formation of the arylhydrazone, followed by indolisation to form the bicyclic indole nucleus, Scheme (8).

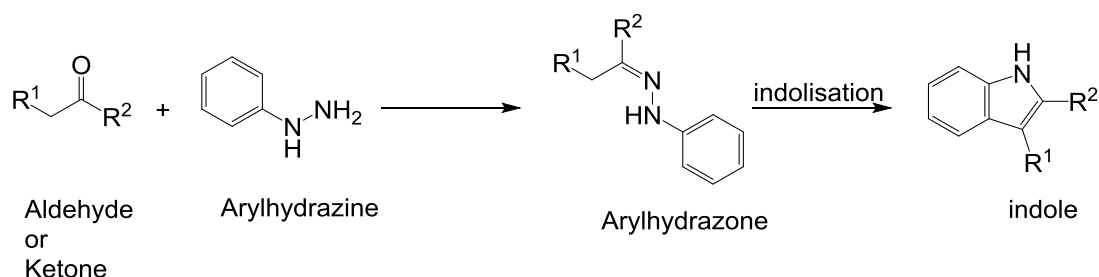

Scheme (8): Fischer indole synthesis

Although the Fischer indole synthesis is very general in scope, it does have some limitations: the most important restriction is that the carbonyl compound must be able to enolise. Moreover, if the intermediate arylhydrazone is not symmetrical, either because the parent ketone has two different alkyl groups attached to the carbonyl carbon atom or because the arylhydrazine has a substituent in the 2 or 3 position, but does not have the same substituent in the corresponding 6 or 5 position, more than one indole (or indolenine, if a non-aromatic product is formed) may be produced. Fortunately, even in such cases where an unsymmetrical arylhydrazone can

give two or more products, it is often possible to secure preferential formation of just one indole. In order to appreciate the significance of these potential complications, it is necessary to review briefly the mechanism of the Fischer indole synthesis.

2.1.2. The Mechanism of the Fischer Indole Synthesis

The first part of the synthesis is the formation of the arylhydrazone. This condensation occurs by a series of elementary steps, including nucleophilic addition of the lone pair on nitrogen to the carbonyl carbon atom of the ketone, proton transfers and elimination of either water or hydroxide anion. Scheme (9) illustrates the reaction of cyclohexanone, **46**, and phenylhydrazine, **47**, to give the corresponding phenylhydrazone, **48**.

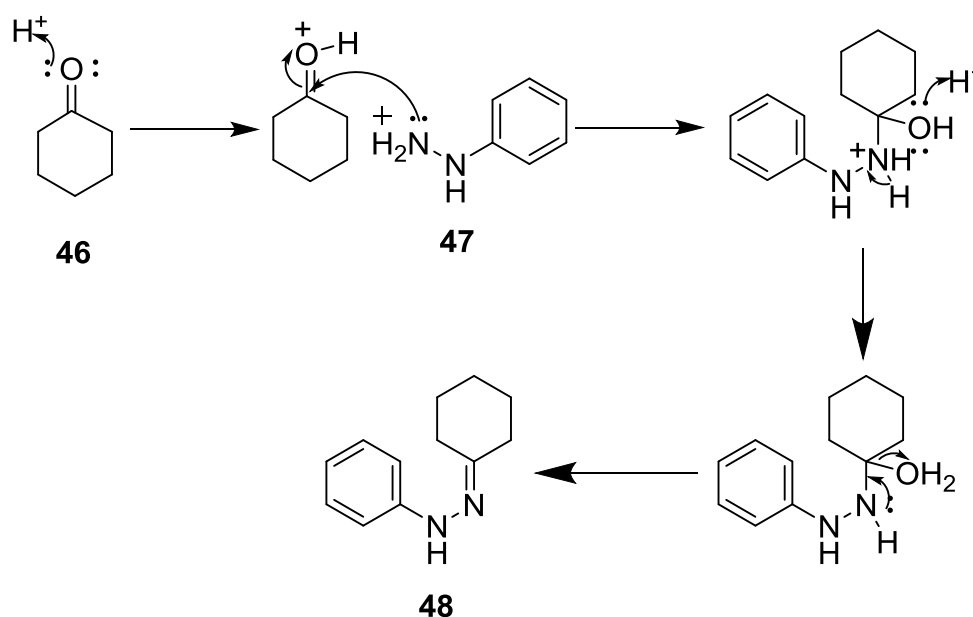

Scheme (9): Formation of the intermediate arylhydrazone.

The second part of the Fischer indole synthesis, the indolisation of the arylhydrazone, is clearly much more complicated. Since the overall

consequences of the overall process include the formation of a new ring and the loss of one of the two nitrogen atoms, early workers devoted considerable attention to elucidating a satisfactory mechanism.¹¹⁹⁻¹²¹ Various pathways were proposed. At least some of these pioneering investigations took place when the concept of organic reaction mechanism was in its infancy. After extensive study, a mechanism that is consistent with the experimental findings and which is now generally accepted was proposed in 1918.^{122, 123} This mechanism involves three distinct steps in the indolisation of the aryldiazone: firstly, tautomerisation to the less stable isomeric ene-aryldiazone; secondly, formation of a new C-C bond via a pericyclic process that may be described as a [3,3]-sigmatropic rearrangement; and, thirdly, loss of ammonia to form an indole nucleus.^{16, 43, 123-125} An illustrative example of these steps is shown in Scheme (10) for the synthesis of tetrahydrocarbazole from the aryldiazone derived from phenylhydrazine and cyclohexanone. Certain aspects of some of these steps are explained in greater detail when discussing the indolisation of the monophenylhydrazones formed from cyclohexan-1,3-diones.

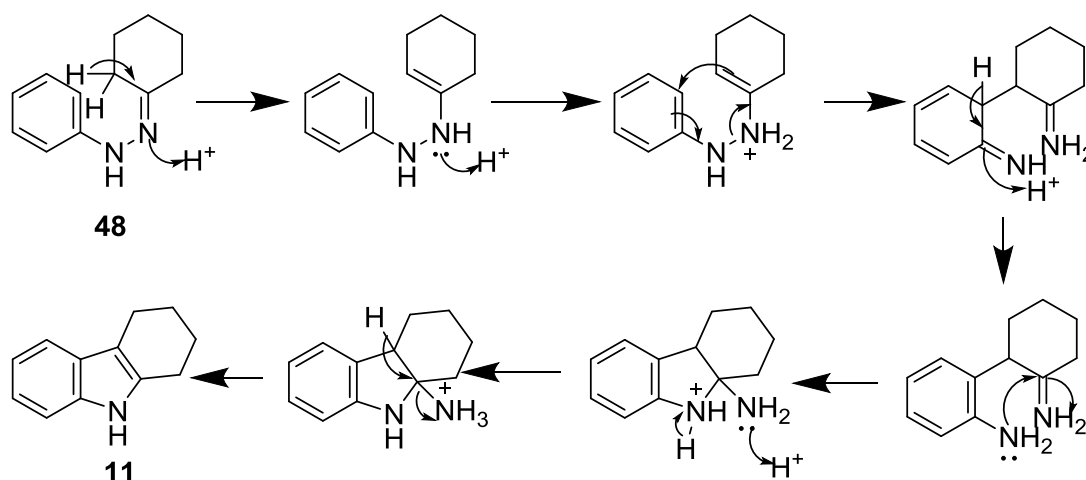

Scheme (10): Indolisation of the cyclohexanonephenylhydrazone.

2.1.3. Regiochemistry of Indolisation

As noted in section 2.1.1., one potential limitation of the Fischer indole synthesis is that the indolisation of arylhydrazones derived from many unsymmetrical ketones may result in the formation of two or more isomeric indoles and/or indolenines.^{43, 126, 127} For example, the cyclisation of the phenylhydrazone of 2-substituted cyclohexanones, **49**, was found to give a mixture of indolenine, **52** and indole, **53**, Scheme (11).¹²⁶ Preliminary studies showed that the direction of indolisation and the ratio of the product are greatly affected by the reaction conditions (i.e. the solvents and the catalysts);¹²⁶⁻¹²⁸ under weakly acidic conditions, such as with glacial acetic acid as the solvent without the addition of stronger acids, the more substituted ene-arylhydrazines, **50**, predominated. Conversely, under strongly acidic conditions, such as with added sulphuric acid, the less substituted ene-arylhydrazines, **51**, were formed. This contrasting behaviour may be attributed to the relative stabilities of the two possible ene-arylhydrazone intermediates.

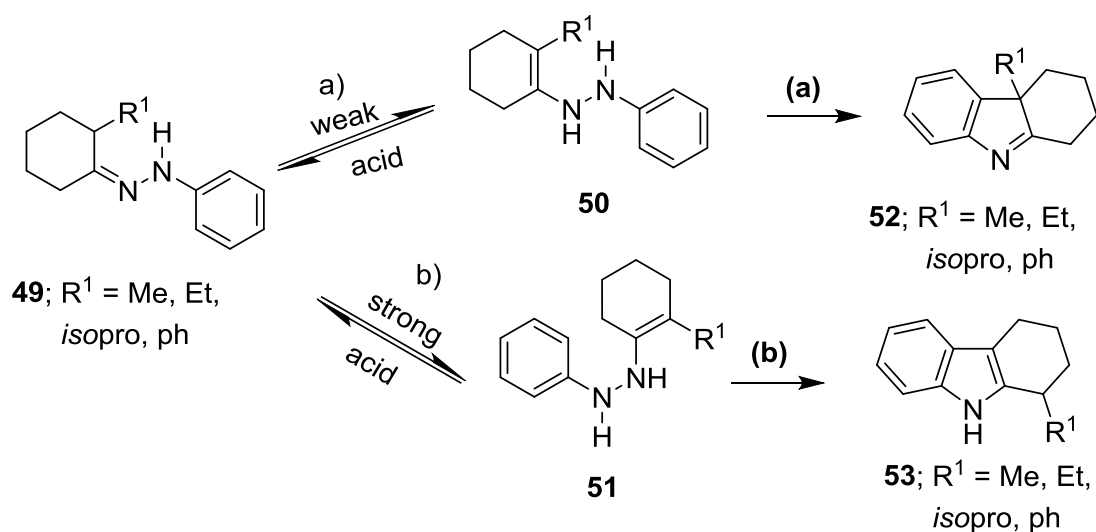

Scheme (11): Indolisation of 2-alkylcyclohexanone monophenylhydrazones; a) indolisation with a weak acid; b) indolisation with a strong acid.

2.1.4 Experimental aspects of the Fischer Indole Synthesis

In a typical procedure, the arylhydrazone is obtained by treating the requisite ketone (or aldehyde) with an equimolar quantity of the appropriate arylhydrazine. The key indolisation sequence may then be effected by moderate heat under thermal conditions, normally with acid catalysis.^{16, 124, 125} Many different catalysts may be used, including mineral acids (sulphuric acid or hydrogen chloride), organic acids (trifluoroacetic acid and various sulphonic acids) and Lewis acids. A particularly convenient method involves the use of an acidic organic solvent, such as formic or acetic acid (or a homologue if a higher temperature than the boiling point of acetic acid is needed). In many instances, isolation of the intermediate arylhydrazone is unnecessary; the reaction can be conducted as a “one-pot” procedure starting from equimolar quantities of the ketone or aldehyde and the arylhydrazine, so that indolisation of the arylhydrazone occurs *in situ*. This advantageous method was discovered as long ago as 1883 by Emil Fischer himself while treating pyruvic acid 1-methylphenylhydrazone, **54**, with alcoholic hydrogen chloride which gave 1-methyl indole-2-carboxylic acid, **55**, Scheme (12).^{16, 43}

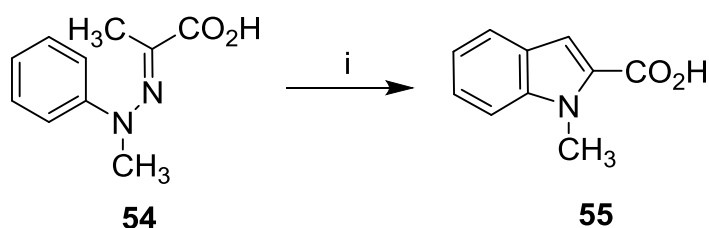

Scheme (12) *Reagents and conditions*: i) alcoholic hydrogen chloride, 5 %.

In the context of the work reported in thesis, the formation of tetrahydrocarbazole was readily achieved by this “one pot” method, simply by dropwise addition during a period of 30 min one equivalent of

phenylhydrazine to a refluxing solution of cyclohexanone in acetic acid. The mixture was then refluxed for a further hour, and poured while still hot into a beaker and allowed to solidify; after isolating and washing the crude product by filtration, recrystallisation gave pure tetrahydrocarbazole in high yield. This example is, of course, particularly straightforward because of the symmetry of both starting materials, which means that only one indole may be produced. It was effectively employed in the preparation of many of the tricyclic indoles, with and without a substituent in the third ring, that were required in this work. In other cases, however, thought must be given to the possibility that more than one product may be formed.

2.2. Synthesis of Indoles

The following sections summarise how the indoles required in this research were prepared. Further details are shown in the experimental section (9.2.1.–9.2.4.). All these heterocyclic compounds were characterised by spectroscopic methods (^1H NMR, ^{13}C NMR, IR and mass spectrometry). High-resolution mass spectrometry was applied to establish their molecular formulae.

2.2.1 Synthesis of Unlabelled Tricyclic Indoles

2.2.1.1. Unsubstituted Tricyclic Indoles and Tricyclic Indoles with one or more alkyl groups in the third ring

These indoles were synthesised without difficulty by condensation of phenylhydrazine, **47**, and the appropriate cycloalkanone, **46**, **56-58**, in a “one pot” procedure in refluxing acetic acid. The published procedure¹²⁹ was significantly improved by performing the reaction under a nitrogen

atmosphere, which greatly reduced the colour of the crude product, thereby removing the need for the use of decolourising charcoal in the final recrystallisation. Illustrative examples are summarised in Scheme (13).

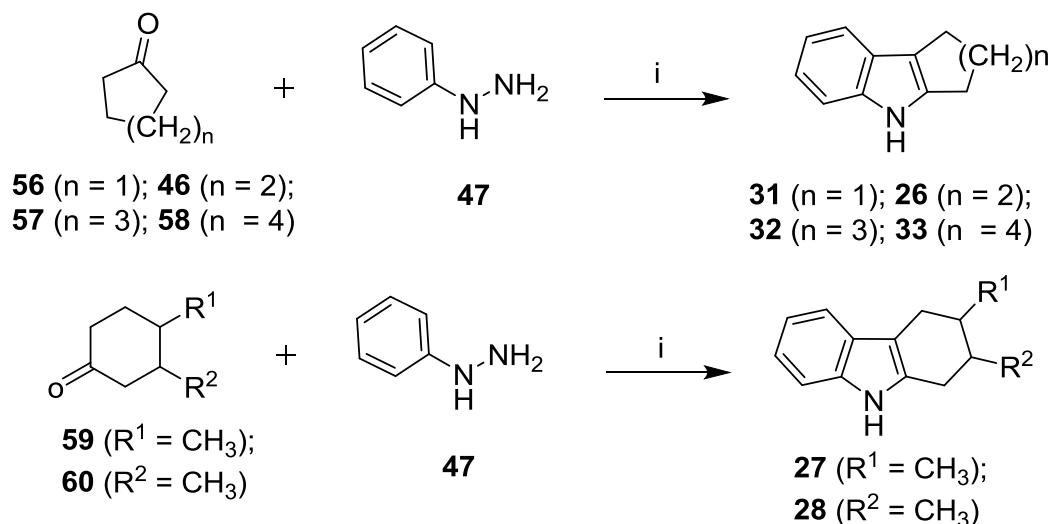

Scheme (13) *Reagents and conditions*: AcOH, 120 °C, N₂, 60-120 mins, 36-54 %.

2.2.1.2. Synthesis of n-oxocycloalkan[b]indoles

The tricyclic indoles with a carbonyl group in the third ring were prepared by two different routes; firstly, by condensation of phenylhydrazine with cyclohexanediones (the Fischer indole synthesis, with isolation of the intermediate monophenylhydrazone);¹⁰² and, secondly, by oxidation of the corresponding tricyclic species without a carbonyl group.

2.2.2.1. Method 1: Fischer Indole Method

Compounds **11**, **13** and **14**, were synthesised from phenylhydrazine and the requisite 1,3-cyclohexanedione, followed by the acid-catalysed indolisation of the intermediate phenylhydrazone, Scheme (14) and (16),

respectively. Some aspects of this process deserve more detailed consideration.

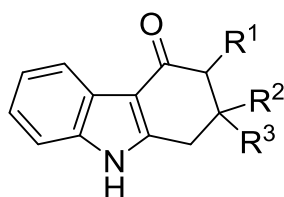

11 ($R^1 = R^2 = R^3 = \text{CH}_3$); **12** ($R^2 = R^3 = \text{H}, R^1 = \text{CH}_3$);
13 ($R^1 = R^2 = \text{H}, R^3 = \text{CH}_3$); **14** ($R^1 = \text{H}, R^2 = R^3 = \text{CH}_3$)

Condensation of 1,3-cyclohexanediones with Phenylhydrazine

The first step of the synthetic pathway involved condensing an equimolar mixture of the appropriate 1,3-cyclohexanedione, **61-63**, with phenylhydrazine, **47**, in dilute acetic acid solution to give a good yield the corresponding monophenylhydrazone, **64-66**,¹⁰² Scheme (14).

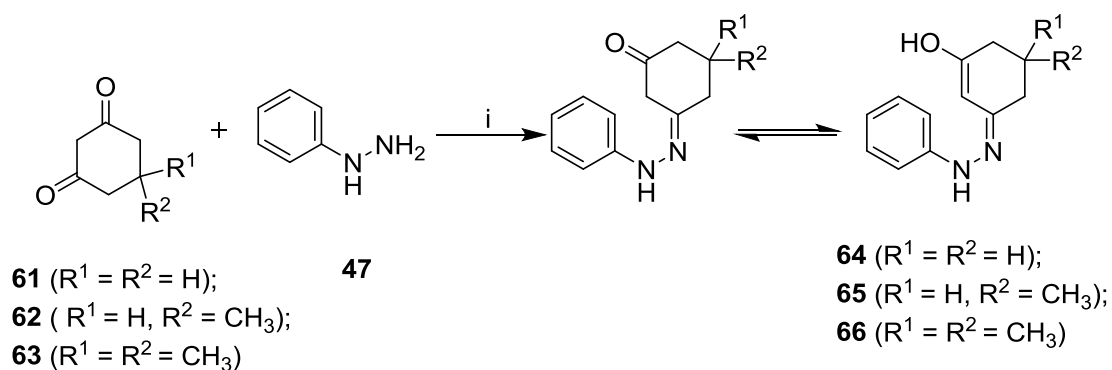

Scheme (14) *Reagents and conditions*: i) AcOH, H₂O, 100 °C, 5 mins, 60–73 %.

The isolation of these monophenylhydrazones, rather than the diphenylhydrazones produced by attack of two different molecules of phenylhydrazine on each of the two carbonyl groups, reflected their structure and stability, as well as the stoichiometry of the reactants. Extensive conjugation of the C=C π -bond of the enol tautomer of the

monophenylhydrazone with the C=N π -bond and with the aromatic ring if the nitrogen atom attached to the aromatic ring is sp^2 hybridised, strongly stabilises this product. One mechanism for the formation of the monophenylhydrazone is shown in Scheme (15). An alternative would be for the phenylhydrazine to attack the carbonyl group of the enol tautomer of the cyclohexan-1,3-dione, thus forming the enol tautomer of the monophenylhydrazone directly, perhaps with additional stabilisation of some of the intermediates by conjugation of the (developing) C=N π -bond with the C=C π -bond in the enol tautomer.

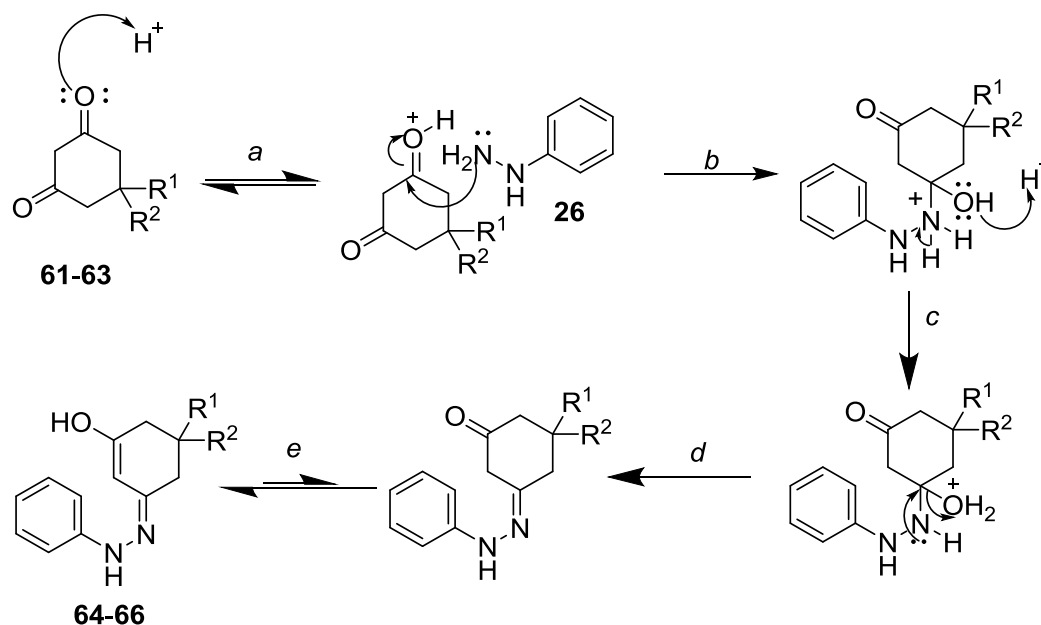

Scheme (15): Proposed mechanism for the formation monophenylhydrazones.

The following elementary steps are involved in the mechanism depicted in Scheme (15). Initial protonation (step **a**) of the carbonyl oxygen atom by the solvent (acetic acid), which also acts as a catalyst, makes the ketone more electrophilic, thereby accelerating the nucleophilic addition of phenylhydrazine (step **b**). There are at least two reasons why the lone pair of electrons on the β -nitrogen is more nucleophilic than that of the α -nitrogen

atom; firstly, because it is less hindered; and, secondly, because the lone pair of electrons on the sp^2 hybridised α -nitrogen atom is delocalised with the aromatic ring, thereby making it less available to donate to a proton or to act as a nucleophile. This nucleophilic addition leads to a tetrahedral intermediate. Proton transfer (almost certainly via the protic solvent, acetic acid, rather than directly between the two heteroatoms attached to the same carbon atom) from the positively charged nitrogen atom to the oxygen atom creates a very good leaving group (water, step **c**). Elimination of water is favoured by the participation of the lone pair of electrons on the β -nitrogen atom with concomitant formation of the new C=N π -bond (step **d**). This addition-elimination reaction is followed by deprotonation of the second nitrogen atom to give the keto tautomer of the desired monophenylhydrazone, (step **e**), which may isomerise to the corresponding enol tautomer. Exactly parallel steps starting from the enol tautomer of the cyclohexan-1,3-dione would give the enol tautomer of the monophenylhydrazole directly, without the final tautomerisation. However, the original nucleophilic addition would be expected to be slower than that on the diketone because the electrophilicity of the carbonyl component would be reduced by conjugation of the C=C and C=O π -bonds of the enol tautomer.

Cyclisation of Monophenylhydrazone to form the Indole Nucleus

The indolisation of the intermediate monophenylhydrazone was first demonstrated in 1923 in the synthesis of **11** by boiling cyclohexane-1,2-dione monophenylhydrazone in HCl and AcOH.¹³⁰ However, in the synthesis of the ketoindoles in this project, a later variant that gave better yields was

adopted: treatment of the monophenylhydrazones of cyclohexanediones, **64-66**, with dilute sulphuric acid (typically 40%) at 100 °C, Scheme (16). The proposed mechanism for this indolisation process is summarised in Scheme (17).

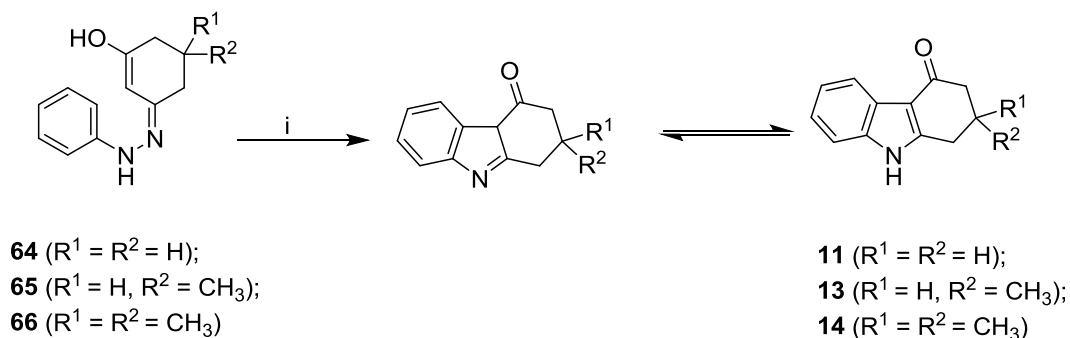

Scheme (16): Reagents and conditions: $H_2SO_4, H_2O, 100\text{ }^\circ C, 90-120\text{ min}, 35-73\%$.

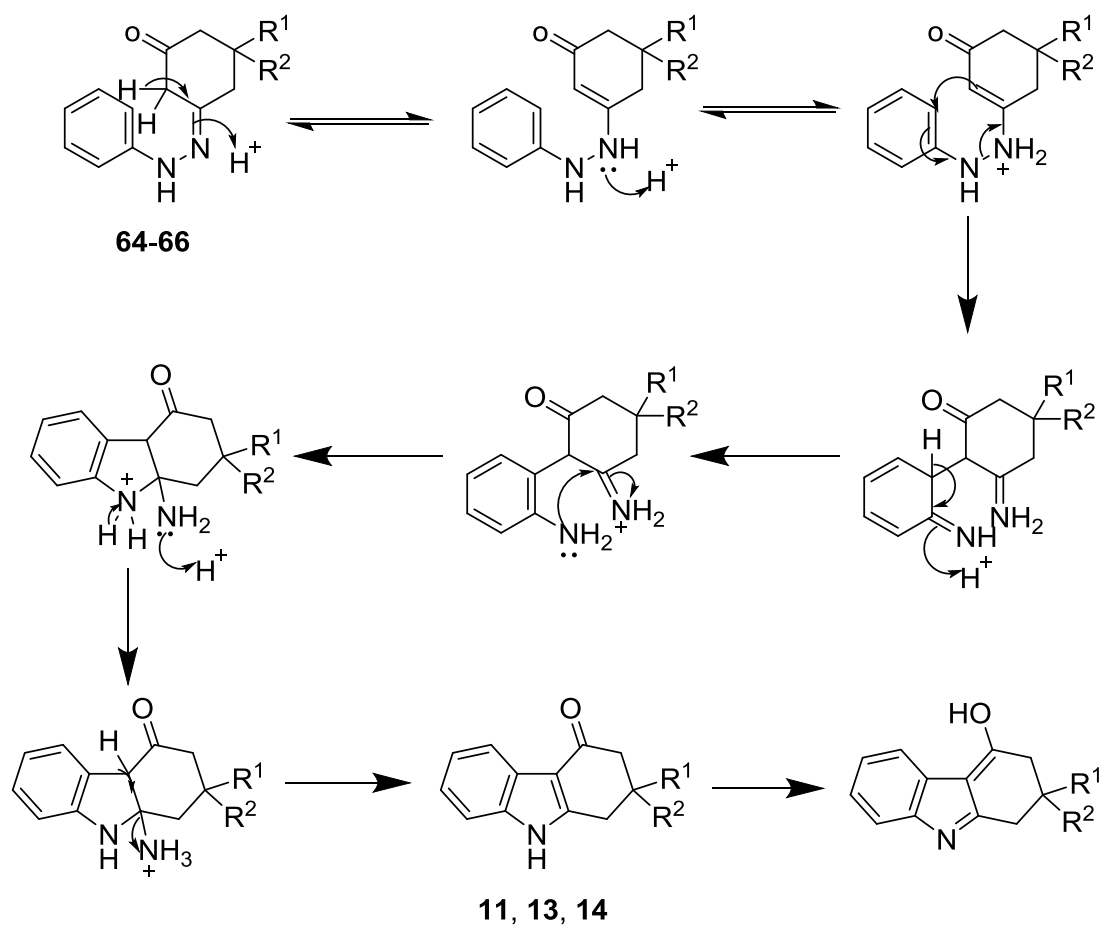

Scheme (17): Proposed mechanism for the indolisation of monophenylhydrazones.

A tautomeric shift of an acidic α -proton to the nitrogen atom gives the ene-phenylhydrazine, (step **f**); this ene-phenylhydrazine which contains a basic sp^3 nitrogen atom, may undergo protonation on this basic nitrogen atom (step **g**), as in the case of the related *o*-benzidine rearrangement. The resultant ene-phenylhydrazine may then undergo the [3,3]-sigmatropic rearrangement, which is the key step (**h**) in the indolisation process. This pericyclic process, which may be facilitated by the positive charge on the nitrogen atom, results in cleavage of the weak N–N σ -bond and the formation of a stronger C–C σ -bond. Re-aromatisation of the six membered carbocyclic ring by loss of a proton from the carbon atom to which the new π C–C bond was formed, with protonation of the nitrogen atom of the intermediate imine, produces an aromatic amine, (step **k**). This step corresponds to tautomerism of the imine functional group to the more stable enamine (which is stabilised because the double bond completes the aromatic sextet). Although hydrolysis of the protonated imine containing the original β -nitrogen atom could give the corresponding carbonyl compound, this step is much less favourable than nucleophilic attack of the lone pair of electrons on the other nitrogen atom (step **l**). This step completes the formation of the central five-membered ring. Further proton transfers between the nitrogen atoms (again, almost certainly via the protic solvent, rather than directly between these heteroatoms, step **m**) results in the formation of an intermediate from which ammonia may be expelled with aromatisation of the heterocyclic ring (step **n**). This last step is depicted in Scheme (17) as occurring by loss of a proton from the carbon atom that is attached to the carbonyl group of the product; however, it is perfectly possible, if not likely, that the lone pair of electrons on

the nitrogen atom in the indole nucleus assists in the elimination of ammonia, with aromatisation of the heterocyclic ring occurring in a subsequent step.⁴³

Ring closure of **64**, **65** and **66** can give two products rising from the two different ene-phenylhydrazines that could be formed from the tautomerisation of the phenylhydrazone, Scheme (18). However, the formation of the ene-phenylhydrazone (via **Route 1**) is favoured;^{16, 104} the most acidic proton located between the two electron withdrawing groups (C=O and C=N), is lost in the enolisation. In addition, enolisation by **Route 1** is more favourable because it results in the formation of conjugated ene-phenylhydrazone, whereas the corresponding species formed by **Route 2** does not have the stabilising conjugation of the C=C and C=N π -bonds.

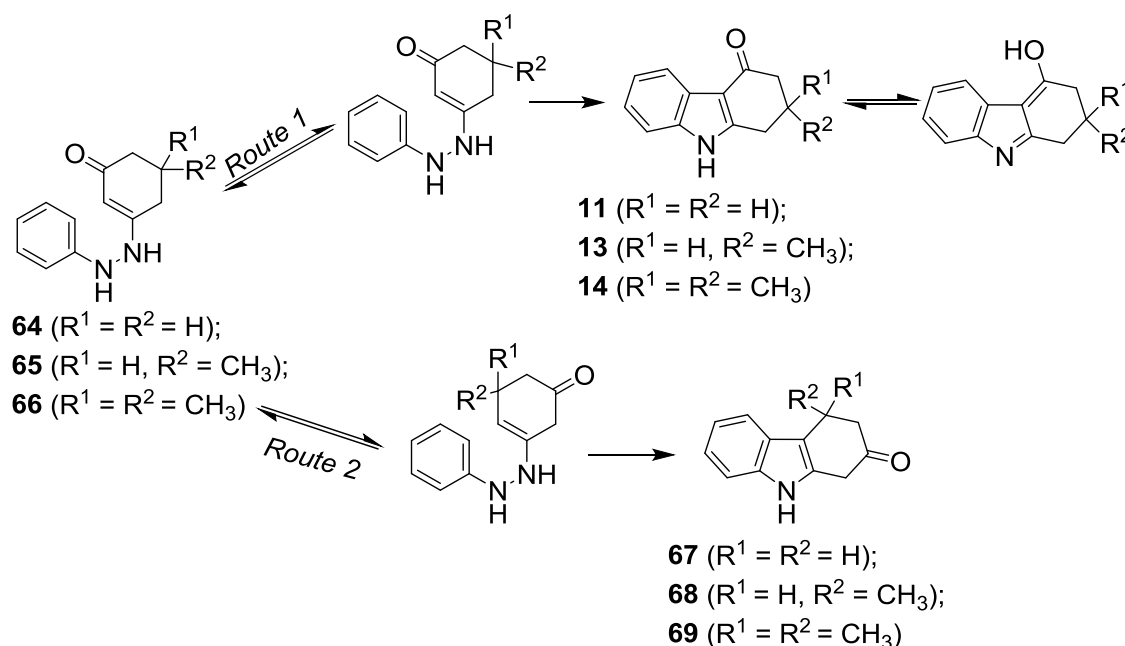

Scheme (18): Phenylhydrazone to ene-phenylhydrazone tautomerism resulting in the possibility of forming isomeric products.

After successfully converting the monophenylhydrazones formed from the cyclohexan-1,3-diones into their corresponding indoles, attempts were made to extend this methodology to synthesising tricyclic indoles with five- and seven-membered third rings, **17** and **18**, Scheme (19). Unfortunately, several efforts to prepare the monophenylhydrazone of cyclopentan-1,3-dione, **70**, by reacting cyclopentan-1,3-dione, **71**, with phenylhydrazine Scheme (20), gave only intractable red tarry material. Furthermore, it was known that 1,3-cycloheptandione is not commercially available and its synthesis requires challenging and potentially hazardous work.^{131, 132} Consequently, another method for the synthesis of these *n*-oxocycloalkan[*b*]indoles was required. Fortunately, the required ketoindoles were accessible by alternative routes involving oxidation of tricyclic indoles that had been prepared by the Fischer indole method.

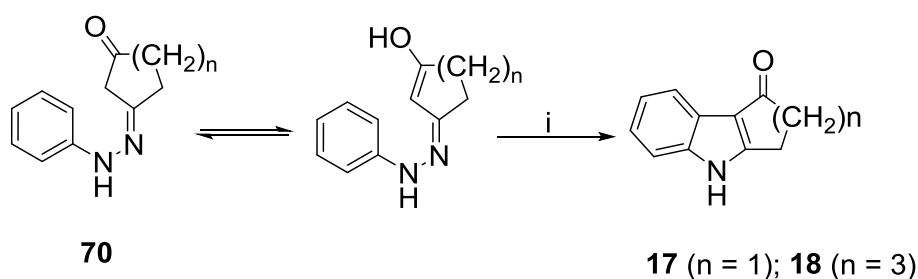

Scheme (19) *Reagents and conditions*: i) H_2SO_4 , H_2O , $100\text{ }^\circ\text{C}$, 90-120 mins.

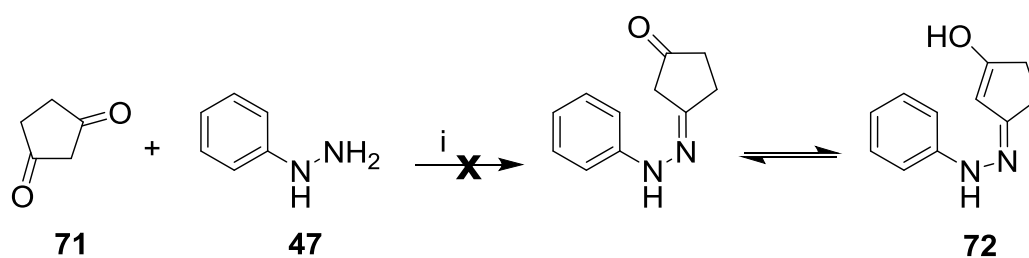

Scheme (20) *Reagents and conditions*: i) AcOH , H_2O , 30 mins.

2.2.2.2. Method 2: Oxidation of Unfunctionalised Tricyclic Indoles

The successful synthesis of the desired ketoindoles, **17**, **18** and **19**, is outlined in Scheme (21) and is based on the selective oxidation of indoles using 2,3-dichloro-5,6-dicyanoquinone (DDQ). This method has been reported for the synthesis of a series of other acyclic and tricyclic indoles, including indoles derived from cyclopentanone to cyclooctanone, in good yield.¹³³ In addition, 3-methyl-1,2,3,9-tetrahydro-4*H*-carbazol-4-one, **12**, which could not be directly prepared via the Fischer indole synthesis, was obtained in moderate yield via this oxidative procedure, Scheme (21).

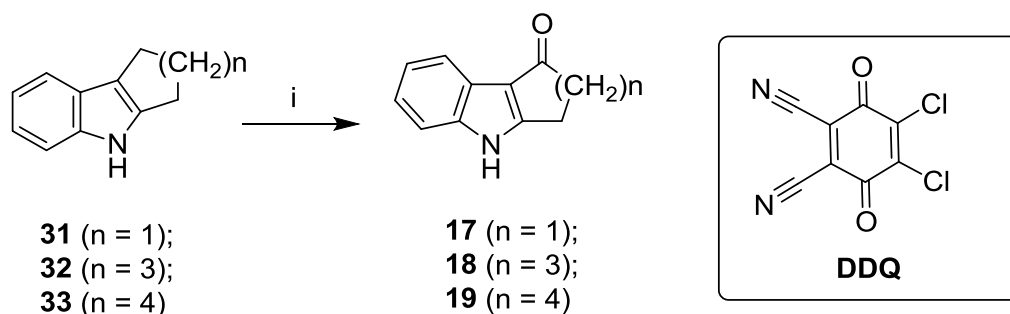

Scheme (21) *Reagents and conditions*: i) THF, 0 °C, DDQ, THF, RT, 1 hr, 36-61%.

2.1.3. Synthesis of 1-, 2- and 3-oxocyclohexan[b]indoles

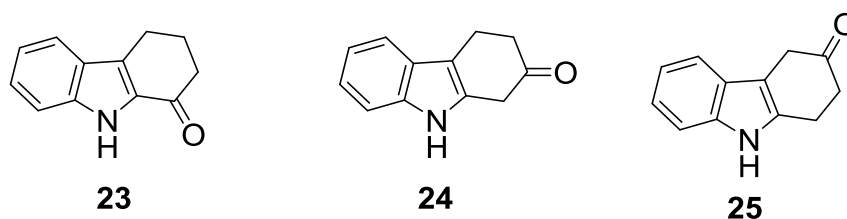

These tricyclic indoles were prepared by condensing the requisite parent cycloalkanone with phenylhydrazine (either directly in “one pot” or by isolating and indolising the intermediate phenylhydrazone), Scheme (22). Controlled oxidation of the unfunctionalised tricyclic indole, **26**, with diiodine

pentoxide (I_2O_5)¹³⁴ provided a convenient means of preparing ketoindoles with a carbonyl group in the 1-position, **23**, (route **A**). In routes (**B** and **C**), acid catalysed deprotonation of the ketal protecting groups, afforded compounds **24** and **25**, respectively, Scheme (**22**). Although this synthetic approach does not entail oxidation of intermediate unfunctionalised tricyclic indoles, it is included here because of the generic similarity of these isomeric ketoindoles with a carbonyl group in various positions in the third ring.

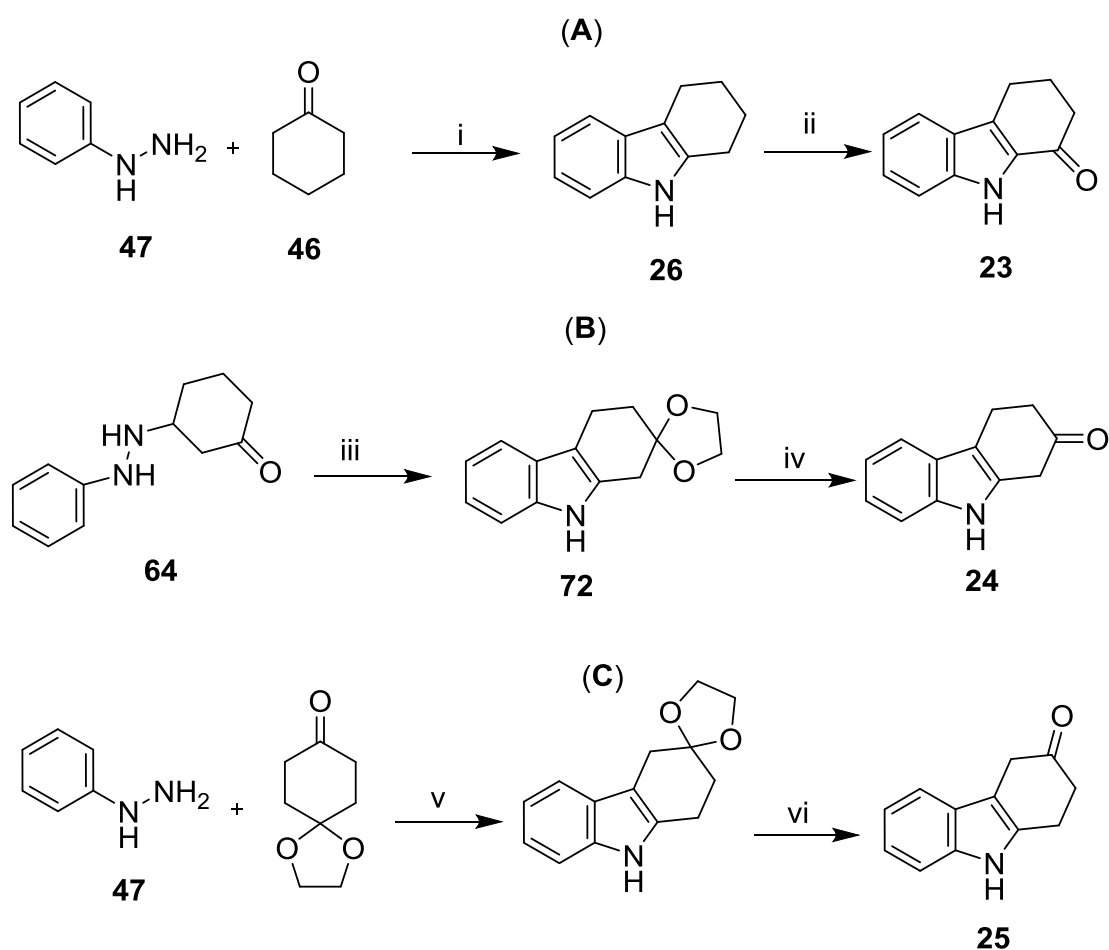

Scheme (**22**) *Reaction conditions:* i) CH_3CO_2H , reflux, N_2 , 60 mins; ii) I_2O_5 , THF, H_2O , RT; 51%; iii) $C_6H_5CH_3$, $HOCH_2CH_2OH$, $p-CH_3C_6H_4SO_3H$, reflux; iv) CH_3OH , H_2SO_4 (10%), RT, 45%; v) C_2H_5OH , $HOCH_2CH_2OH$, 190 °C; vi) THF, HCl (15%), rt, 62%.

2.3. Synthesis of Deuterium Labelled Indoles

In order to obtain more insight into the fragmentation of M^+ and MH^+ ions formed in the mass spectrometer from selected tricyclic indoles, their deuterium labelled analogues, **29**, **30**, **35** and **36**, were synthesised.

2.3.1 Unfunctionalised Tricyclic Indoles

2.3.1. Method 1: Fischer Indole Synthesis

Retrosynthetic analysis of the unfunctionalised tricyclic indoles via the retro-Fischer indole synthesis reveals phenylhydrazine and the corresponding tetradeuteriocycloalkanones, **29**, **30**, **35** and **36**, Scheme (23), as starting materials. Further analysis of the required tetradeuteriocycloalkanones by functional group interconversion (FGI, of C-D to C-H bonds) reveals the parent cycloalkanones, which would be expected to undergo exchange of the protium (H) atoms on the α -carbon atoms for deuterium (D) atoms when subjected to base-catalysed exchange with sodium deuterioxide in deuterium oxide (NaOD/D₂O).¹³⁵ It should be noted that two of the four deuterium atoms in the labelled cycloalkanone are lost during the forward reaction sequence because one of the α -carbon atoms and the original carbonyl carbon atom become the quaternary carbon atoms that form the C=C bond where the second and third ring are fused in the tricyclic indole. This apparent inefficiency of introducing deuterium atoms that are then removed is offset by the ease of the exchange process and the low cost of deuterium oxide.

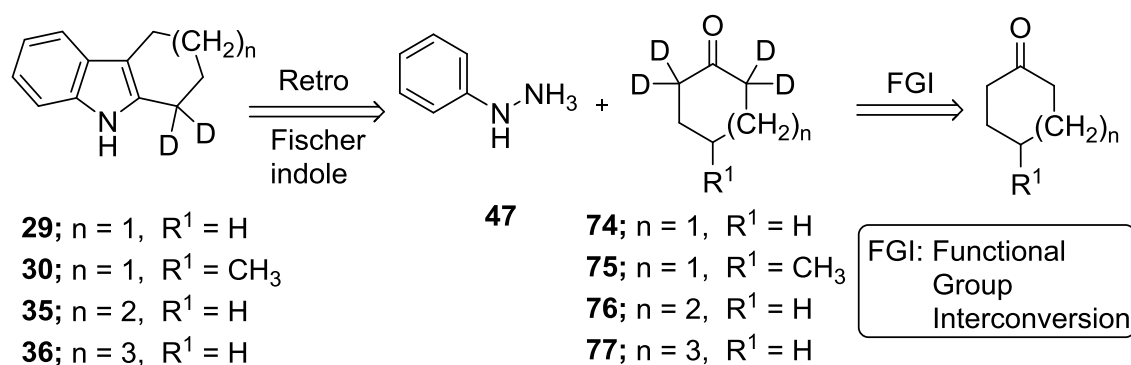

Scheme (23): Retrosynthetic analysis of **52–55**.

Three successive exchanges of cyclohexanone with sodium deuterioxide in deuterium oxide in the presence of a phase transfer catalyst gave tetradeuteriocyclohexanone, **74**, with a very high level of deuterium incorporation (at least 97 %), as indicated by 1H NMR, Scheme (24).

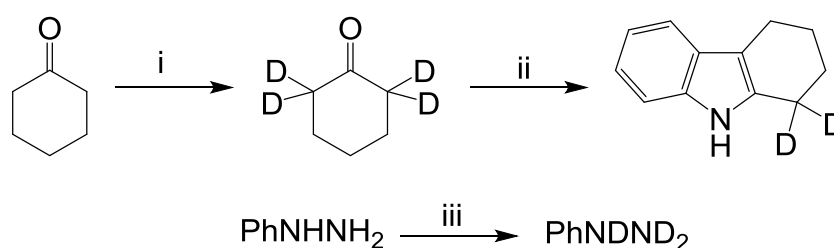

Scheme (24) *Reagents and conditions*: i) D_2O , NaOD, $PhCH_2N(C_2H_5)_3^+Cl^-$; repeat twice; ii) $PhNDND_2$, CD_3CO_2D , Δ ; iii) D_2O , repeat twice.

However, when **74** was reacted with phenylhydrazine in a one pot Fischer indole method in the presence of CH_3CO_2H as solvent and catalyst, 1H NMR analysis of the product revealed that the labelled tetrahydrocarbazole, **29**, had been formed with only a relatively low level (40%) of deuterium incorporation. In order to obtain the labelled product with a higher level of deuterium incorporation (ideally greater than 95%), it was necessary to ascertain how the loss of D occurred. After considering the reaction mechanism, it appeared that there are two obvious types of protium

(H) atoms attached to a heteroatom that could easily have exchanged with the deuterium (D) atoms in the tetradeuteriocyclohexanone, **74**, during the synthesis of the tetrahydrocarbazole: firstly, the three protium atoms on the nitrogen atoms in the phenylhydrazine; and, secondly, the acidic proton on the oxygen atom of the unlabelled acetic acid solvent. It is also possible, but less likely, that certain protium atoms attached to carbon atoms could participate in the “back exchange” process(es) that erode the positional integrity of the CD₂ group that becomes incorporated in the third ring. At least four possibilities exist: firstly, the four protium atoms in the carbocyclic aromatic ring in the tricyclic indole (provided that exchange of these ring protons can occur during or after the formation of the product); secondly, a pair of protium atoms in the CH₂ group in position 4 of the third ring (the methylene group in position 1 of the third ring is derived from one of the two CD₂ groups in the tetradeuteriocyclohexanone); thirdly, the three protium atoms of the methyl group of the unlabelled acetic acid (CH₃CO₂H) solvent; and, fourthly, one of the protium atoms in an ortho position in the phenylhydrazine is eventually lost in the aromatisation step in the indolisation [see step **k** in Scheme (**17**)]. Any of these carbon-bound protons could, in principle, contribute to the undesirable “back exchange” process(es).

In general, hydrogen atoms attached to a heteroatom, especially oxygen and nitrogen, participate much more rapidly in exchange processes than those attached to carbon atoms, especially in protic solvents and under acidic conditions. These considerations suggest that the origin of the protium atoms that erode the positional integrity of the CD₂ group in the labelled tetrahydrocarbazole is likely to be the four atoms that are attached to the

oxygen and nitrogen atoms, respectively, of the acetic acid and phenylhydrazine.

There are convincing reasons for discounting the possibility that the protium atoms of the aromatic ring of the indole nucleus do participate in the exchange processes, especially the fact that there is no change in the relative integration of the signals for these aromatic protons and those of the two methylene groups of the third ring that resonate at highest field. Similar remarks apply to the protons of the tetradeuteriocyclohexanone that eventually become part of the methylene group in position 4 of the tetrahydrocarbazole. It is, however, perfectly possible that reversible enolisation of the unlabelled acetic acid [to form $\text{CH}_2=\text{C}(\text{OH})_2$] under acidic conditions might contribute to the "back exchange" of the deuterium atoms in the CD_2 groups of the tetradeuteriocyclohexanone, particularly since the acetic acid is present in excess as the solvent. Nevertheless, it is intuitively more likely that the major causes of the low level of incorporation of deuterium in the labelled tetrahydrocarbazole are the more acidic protons attached to oxygen and nitrogen in the reactants and solvent. It must also be remembered that this reaction was done on a 12 mM scale. Consequently, the relative proportions of protium and deuterium atoms on the various sites in the reagents and the solvent can be estimated, at least approximately. There should be up to 50 mM of protium atoms on the nitrogen atoms and one of the ortho positions of the phenylhydrazine (four per molecule of reagent), 50 mM of deuterium atoms on the α -positions of the labelled cyclohexanone (four per molecule of starting material) and roughly 75 mM of protium atoms on the oxygen atoms of the acetic acid solvent (one per

molecule of solvent, but it is present in great excess). If these protium and deuterium atoms were to become randomly distributed in the exchange processes (so that any two of them were to end up in the methylene group of the non-aromatic ring), level of deuterium incorporation would be approximately 30% (that is, $100 \times 50/175$). This figure is quite close to the observed value. The deviation from the experimental value could reflect either incomplete exchange (which would mean that the erosion of the positional integrity of the CD_2 group was less extensive than the theoretical maximum) or ineffective participation by some protium atoms (most probably that in the ortho position of the phenylhydrazine (which would reduce the number of participating protium atoms, thus lowering the maximum possible erosion of the positional integrity). On the assumption that this analysis is reasonably accurate, one of the main potential sources of “exchangeable” protium atoms was eliminated by and substituting CD_3CO_2D for CH_3CO_2H as solvent. This modification raised the level of deuterium incorporation to approximately 65%.

The next step was to remove the other source of readily exchangeable protium atoms by shaking the phenylhydrazine with D_2O to introduce NDs instead of NHs. A high level of incorporation (exceeding 92%) of deuterium (to form trideuteriophenylhydrazine, $C_6H_5NDND_2$, **47-D₃**) was achieved by repeating the shaking three times with fresh portions of D_2O . When tetradeuteriocyclohexanone was condensed with trideuteriophenylhydrazine in tetradeuterioacetic acid (CD_3CO_2D) as the solvent, the desired labelled tetrahydrocarbazole was obtained with a deuterium incorporation that exceeded 92%. Similar results were secured when other

tetradeutriocycloalkanones, **29**, **30**, **35** and **36**, were treated with $C_6H_5NDND_2$ in the presence of CD_3CO_2D as the solvent. This method eventually permitted the preparation in moderate to good yield of the desired tricyclic indoles, **29**, **30**, **35** and **36**, with a CD_2 group in the 1-position of the third ring, Scheme (25).

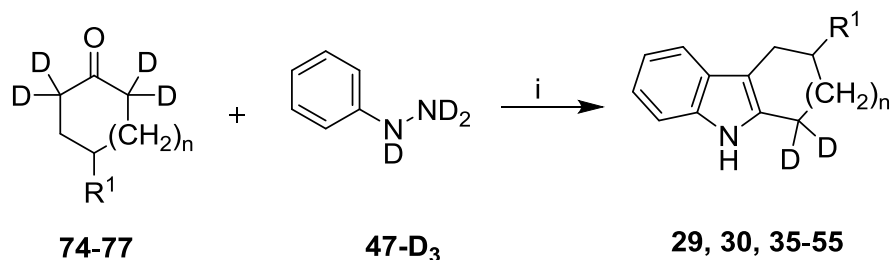

Scheme (25) *Reagents and conditions*: i) CD_3CO_2D , 120 °C, N_2 , 30-120 min, 42-63%.

2.3.2. Method 2: Oxidation of Unfunctionalised Tricyclic Indoles followed by Reduction

An alternative retrosynthetic analysis of labelled tricyclic indoles entails functional group addition (FGA) to reveal a ketoindole, which itself may be further analysed by functional group removal (FGR) to the corresponding unlabelled indole, Scheme (26).

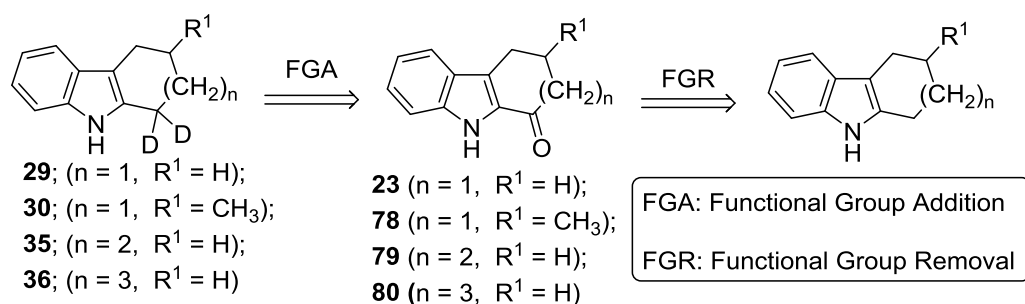

Scheme (26): Retrosynthetic analysis of labelled tricyclic indoles via functional group addition and removal.

Although this analytical sequence may seem illogical in so far as a carbonyl group is introduced only to be removed, the facile reduction of certain ketoindoles by lithium aluminium hydride (LiAlH_4) to the corresponding unfunctionalised indoles made the forward route to the analogous labelled indoles very attractive for three reasons. Firstly, the starting materials, the unfunctionalised tricyclic indoles, had already been prepared, usually by the Fischer indole synthesis; secondly, the forward sequence involves only two further steps, the oxidation and the subsequent reduction with LiAlD_4 ; and, thirdly, it appeared that the two deuterium atoms could be introduced in the chosen position with high selectivity and in good yield, without any complications arising from the exchange processes that complicated the Fischer indole synthesis starting from tetradeuteriocycloalkanones.

In practice, the first step in the forward sequence, the oxidation of the *n*-cycloalkan[*b*]indoles with DDQ to form the *n*-oxocycloalkan[*b*]indoles worked well. Unfortunately, however, the subsequent reduction with LiAlD_4 reduction did not always furnish the desired product, even after the intermediate ketoindole had been purified by chromatography.

On the other hand, one positive outcome of the analysis shown in Scheme (26) was the realisation that the deuterium labelled *n*-oxocyclohexan[*b*]indoles, **15**, **16**, **20** and **21**, could be prepared by oxidation of their labelled unfunctionalised counterparts, **29**, **30**, **35** and **36**, which had already been prepared. Oxidation of the unfunctionalised labelled indoles with DDQ in tetrahydrofuran (THF) at 0 °C under an inert nitrogen atmosphere gave the desired labelled ketoindoles, Scheme (27). Integration

of the requisite signals in their ^1H NMR spectra revealed that the incorporation of deuterium in the relevant CD_2 group of compounds, **29**, **30**, **35** and **36**, was essentially the same (in excess of 92%) as that in the unfunctionalised species.

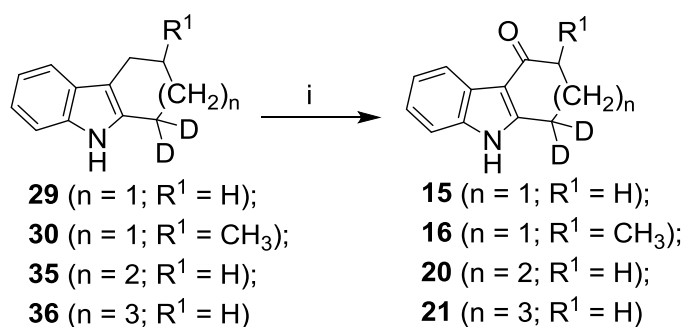

Scheme (27) Reaction conditions; i) THF, $0\text{ }^\circ\text{C}$ then DDQ, THF, RT, 1 hr, 36-61%.

2.4. Conclusion

In summary, a total of 24 model compounds were synthesised by Fischer indole methodology; 10 unfunctionalised tricyclic indoles and 14 tricyclic indoles with a carbonyl group in different position of the third ring. The tricyclic indoles with a carbonyl group included all four isomers of the 6,5,6 with a carbonyl group in each of the positions of the third rings. The compounds were prepared in order to investigate whether the position of the carbonyl group could be determined by a combination of mass spectrometry and vibrational spectroscopy see Chapter 3. In addition, four unfunctionalised deuterium labelled indoles were synthesised to be used as internal standards to establish the detection thresholds of indoles and related compounds in a mixture, Chapter 4.

3.0. MASS AND VIBRATIONAL SPECTRA OF TRICYCLIC INDOLES

3.1. Introduction

The pervious chapter described the synthesis of the model compounds using the Fischer indole method. The next step is to use a combination of mass and vibrational spectroscopy (IR and Raman) for detecting and determining the presence of carbonyl and/or methyl group(s) in these model tricyclic indoles.

The complementary nature of these spectroscopic methods [vibrational spectroscopy [(which is non-destructive and, in the case of Raman spectroscopy, a surface technique) and mass spectrometry (which is versatile and extremely sensitive)] are great choices. For instance, the presence and position methyl group in 1,4-diarylbutadienes has been determined by a combination of mass and Raman spectroscopy.

For the *n*-cycloalkan[*b*]indoles, particular attention is focused on the use of infrared spectroscopy to determine whether these compounds may best be described as ketoindoles or hydroxyindolenines. Computational modelling has been applied to shed further light on this interesting question. In the electron impact spectrum of these indoles, the fragment ions will be used to distinguish between the tricyclic indoles with various ring patterns and variations in the position of the carbonyl group in the non aromatic third ring. Eight deuterium labelled analogues will be investigated, in the hope of making more detailed assignments of the vibrational spectra and/or the fragmentation patterns in the mass spectra of these heterocycles.

3.2. Mass Spectra of Tricyclic and Tetracyclic Indoles

3.2.1. EI spectra of Tricyclic Indoles

The fragmentation patterns of some ionised *n*-oxocycloalkan[*b*]indoles (Section 3.2.1.1 and 3.2.1.2) and *n*-cycloalkan[*b*]indoles (Section 3.2.1.3) are summarised in this section. The size of the fused rings in polycyclic systems are denoted by numbers; thus, “6,5,6” denotes a system such as a tetrahydrocarbazole in which the indole is fused to a six membered third ring. All these compounds showed intense molecular ion (M^+) signals, as is the case with most polycyclic aromatic compounds. The relative molecular mass (RMM) and molecular formula (MF) were easily determined from these M^+ signals.

3.2.1.1. EI Mass spectra of *n*-oxocycloalkan[*b*]indoles

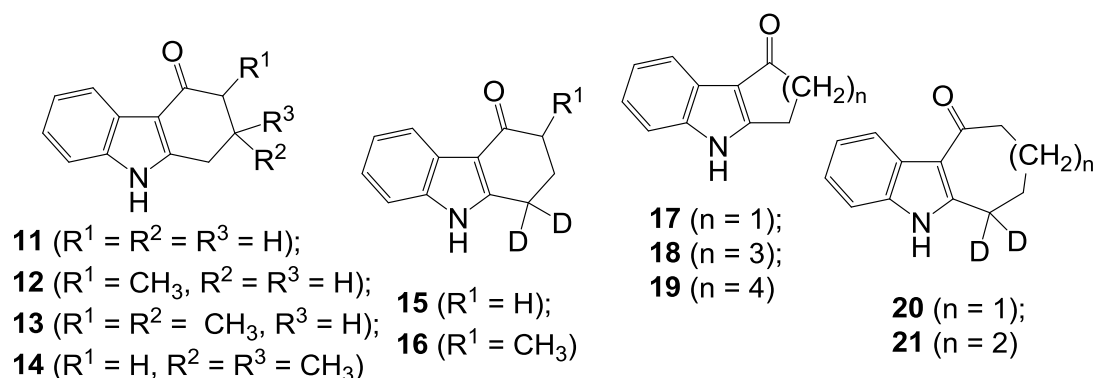

A total of eleven oxo-cycloalkan[*b*]indoles were studied, four of which have been previously investigated under EI conditions, and their fragmentation established.^{82, 83} As expected, these spectra show strong M^+ signals with a relative intensity (RI) over 80%. In the case of tricyclic indoles where the third ring is smaller (“6,5,5”; **17**) or bigger (“6,5,7”, **18**) than in the “6,5,6” series, the M^+ signals is the base peak, Tables (2) and (3).

Table (2): Important signals in the EI spectra of **11-14**

Compound								Assignment
11		12		13		14		
m/z	RI ^a	m/z	RI ^a	m/z	RI ^a	m/z	RI ^a	
185	92	199	85	199	88	213	98	M ⁺
184	3	198	3	198	1	212	1	[M-H] ⁺
-	-	184	9	184	4	198	3	[M-CH ₃] ⁺
157	100	-	-	-	-	-	-	[M-C ₂ H ₄] ⁺
-	-	157	100	157	100	-	-	[M-C ₃ H ₆] ⁺
-	-	-	-	-	-	157	100	[M-C ₄ H ₈] ⁺
129	75	-	-	-	-	-	-	[M-C ₂ H ₄ -CO] ⁺
-	-	129	65	129	71	-	-	[M-C ₃ H ₆ -CO] ⁺
102	16	-	-	-	-	-	-	[M-C ₂ H ₄ -CO-HNC] ⁺
-	-	-	-	-	-	129	65	[M-C ₄ H ₈ -CO] ⁺
-	-	102	15	102	18	-	-	[M-C ₃ H ₆ -CO-HNC] ⁺
-	-	-	-	-	-	102	16	[M-C ₄ H ₈ -CO-HNC] ⁺

^a RI: relative intensity, measured by peak height and normalised to a value of 100 units for the most intense signal.

In each case, the EI spectrum is very clean, being dominated by M⁺, [M-C_nH_{2n}]⁺ and/or [M-C_nH_{2n+1}]⁺ peaks. The spectra of tricyclic indoles with a five or six membered third ring contain strong [M-C_nH_{2n}]⁺ signals; in contrast, the homologues with a 6,5,7 and 6,5,8 ring pattern show [M-C_nH_{2n+1}]⁺ peak(s). These diagnostic differences permit indoles with a 6,5,7 ring pattern, **18**, to be distinguished from their 6,5,6 isomers with a methyl group in the third ring (**12** and **13**).

In contrast to the spectra of **17**, **18** and **19**, the base peak in the spectra of **11-14** appears at m/z 157. The spectrum of **11** shows peaks at m/z 157 (RI = 100) and 129 (RI = 74); these peaks could be interpreted either as $[M-CO]^+$ or $[M-C_2H_4]^+$ and $[M-CO-C_2H_4]^+$ or $[M-C_2H_4-CO]^+$, respectively. However, the introduction of a methyl group on either carbon 2 or 3 in the third ring (as in the case of **12** and **13**, respectively) does not induce a shift from m/z 157 to 171, as would be the case if this ion was correctly assigned to be $[M-CO]^+$, but instead leads to loss of the larger alkene, C_3H_6 . Furthermore, the spectrum of **14** (a “6,5,6” species, with two methyl groups on carbon 2 in the third ring) shows a peak at m/z 157, corresponding to loss of C_4H_8 . The fragmentation of these ionised methyl analogues of “6,5,6”, **12-14**, clearly shows that the correct interpretation of the signals at m/z 157 and 129 is $[M-C_2H_4]^+$ and $[M-C_2H_4-CO]^+$, respectively. The loss of ethylene in the spectrum of **11** may be explained as a cycloreversion (sometimes loosely described as a “Retro Diels Alder” (RDA) reaction) producing the stable product ion (**p**), Scheme (28).

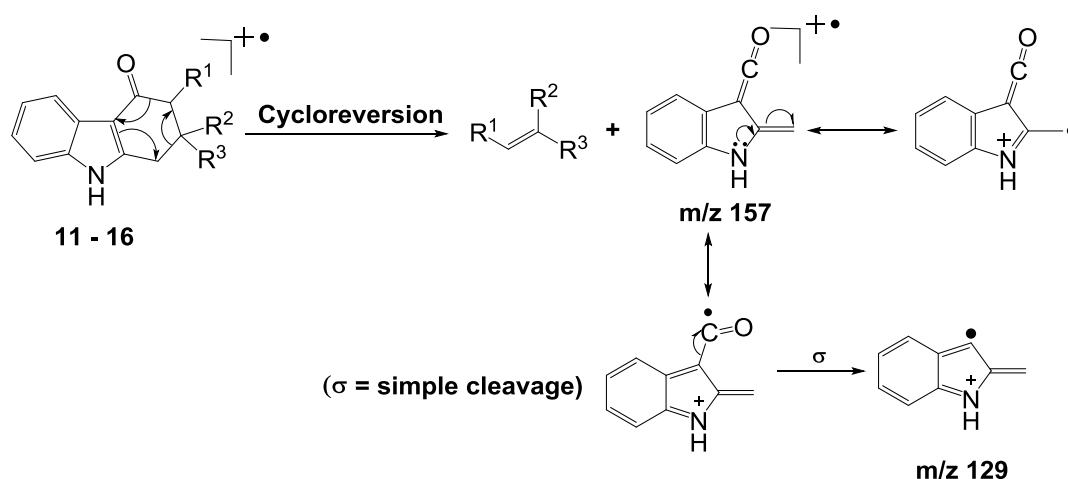

Scheme (28): Proposed mechanism for fragmentation of ionised 6,5,6 *n*-oxocyclohexan[*b*]indoles, **11-14**.

This interpretation is broadly in agreement with earlier work.^{82, 83} The spectra of **12** and **13** show a peak at $[M-42]^+$; similarly, the spectrum of **14** shows a signal at $[M-56]^+$; as in the case in the fragmentation of 11^+ , the ions corresponding to these peaks may be represented as (**p**), Scheme (28) and Figure (3). Hence these compounds with R^1 , R^2 or $R^3 = CH_3$ provide new and additional support for the cycloreversion. These characteristic fragmentations of ionised homologues of **11** allow the presence of one or two methyl group(s) in the third ring to be detected because extra methyl group(s) result(s) in the loss of a larger alkene than C_2H_4 . After the loss of an alkene, a secondary fragmentation by loss of carbon monoxide (CO) may take place by simple cleavage to give a bicyclic distonic ion (**q**) at m/z 129. Another fragmentation which is seen in the spectra of **12-14** is loss of a neutral species with 15 mass units from M^+ , resulting in a peak at m/z 184 and m/z 198 in the respective spectra of **12** and **13**, and **14**. This signal could be interpreted as loss of (R^1) \cdot or (R^2) \cdot from 12^+ and 13^+ via simple cleavage where R^1 and R^2 are both methyl groups. In the spectrum of **14**, $[M-CH_3]^+$ could correspond to simple cleavage with loss of either R^2 or R^3 . The loss of an alkene by the cycloreversion is also supported by the behaviour of deuterium labelled counterparts of 11^+ and 15^+ . The primary fragment ions in the spectra of **15** and **16** at m/z 159 in both cases could be interpreted as $[M-C_2H_4]^+$ and $[M-C_3H_6]^+$, respectively. These ions can also be formulated by ion (**p**) as their unlabelled counterparts in Scheme (28) above. In the spectrum of **15**, the loss of C_2H_4 (to give m/z 159; RI 92) (rather than $C_2H_2D_2$ (to give m/z 158; RI 15) and C_2H_3D (to give m/z 157; RI 7) with reasonably high selectivity is consistent with the predominant loss of C_2H_4 from 11^+ ,

without prior rearrangement that might erode the positional integrity of the CD₂ group and lead to incorporation of deuterium in the eliminated ethylene.

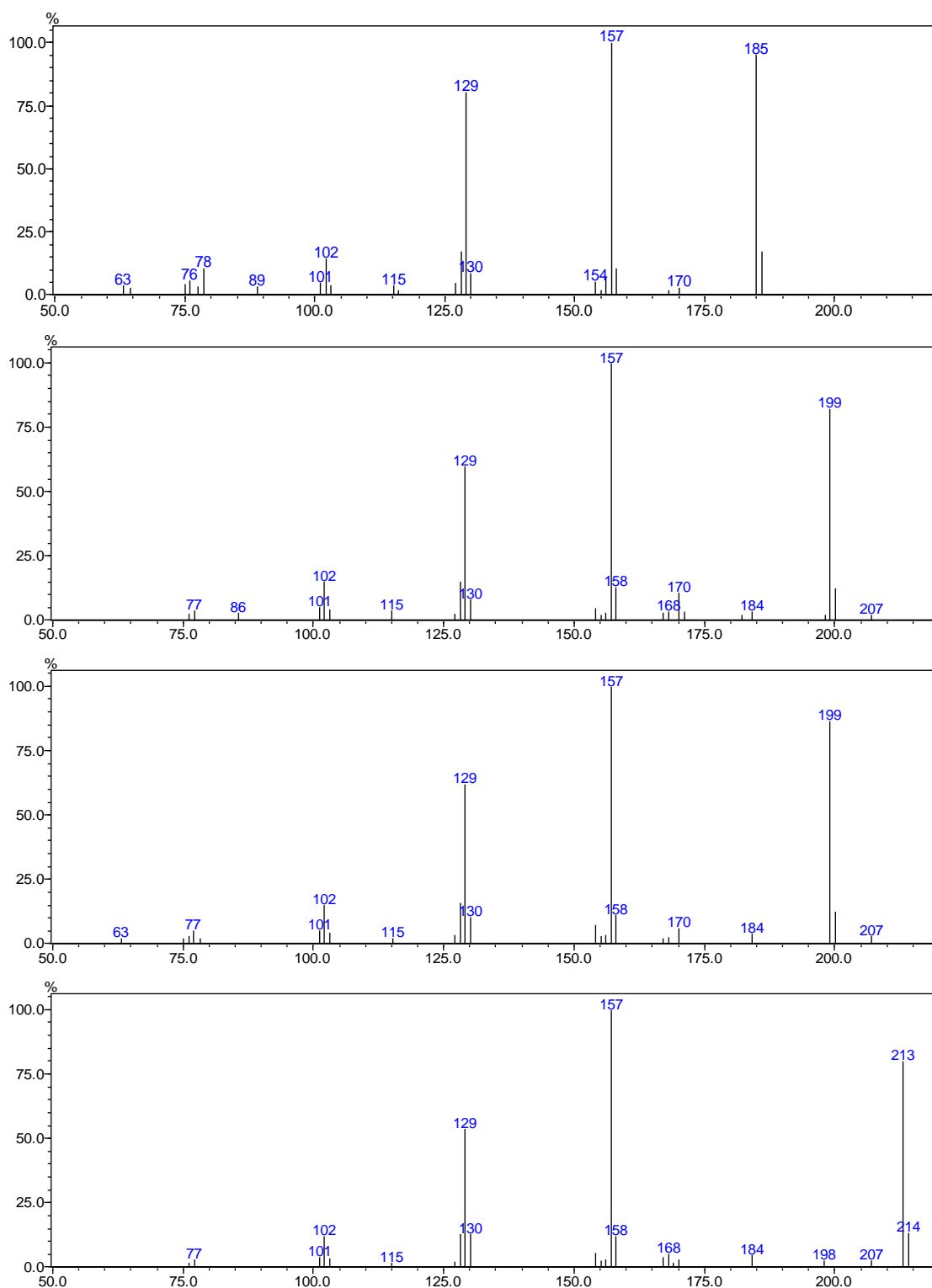
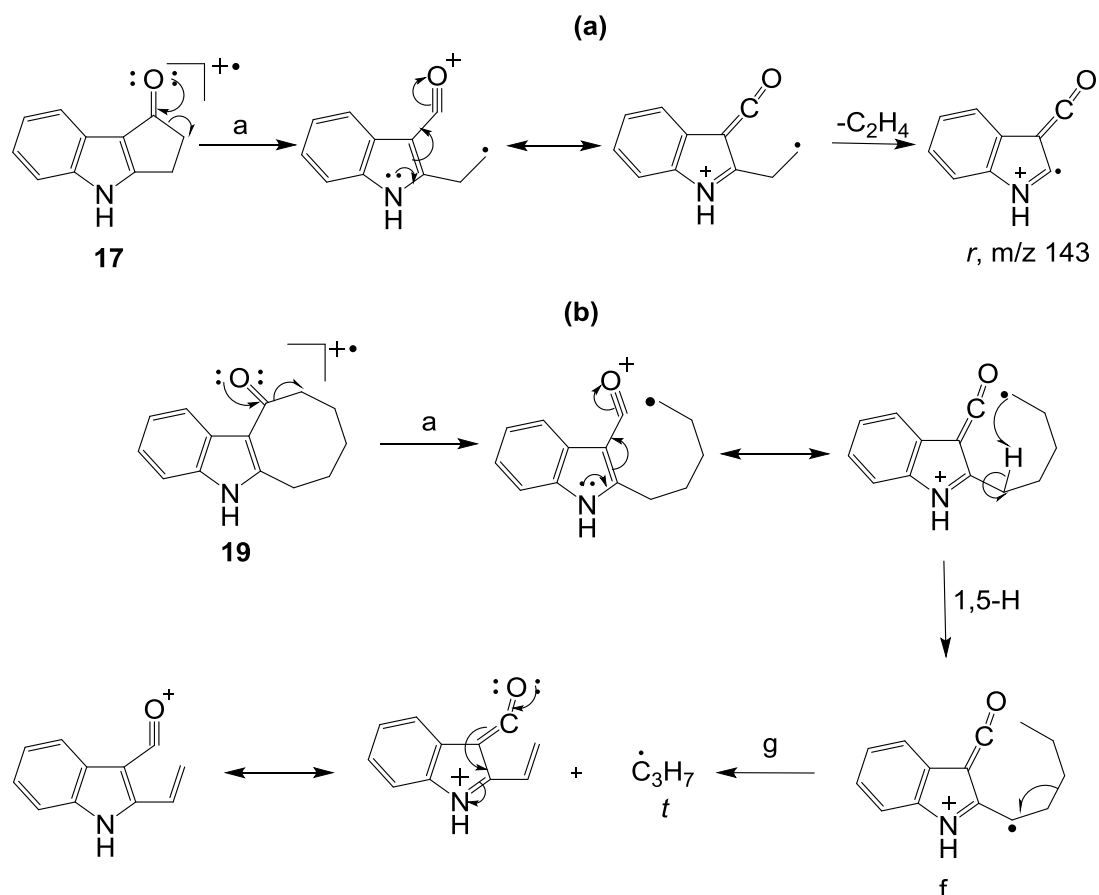

Figure (3): Electron ionisation mass spectra of oxocycloalkan[b]indoles with a 6,5,6 ring pattern (11, 12, 13 and 14, top to bottom)

However, a limited amount of exchange, presumably by reversible 1,2-H/D shifts, does precede ethylene loss. Nevertheless, these labelling experiments provide additional confirmation that the C₂H₄ lost from **11**⁺ originates from the methylene groups containing C(2) and C(3). This conclusion is in agreement with earlier work.^{82, 83} In comparison with the spectra of their unlabelled counterparts, the major peaks in the spectra of **15** and **16** are shifted up by 2 m/z units, which is due to the incorporation of deuterium from the relevant CD₂ group.

The secondary fragment ions in the spectra of **15** and **16** can be interpreted as [M-C₂H₄-CO]⁺ and [M-C₃H₆-CO]⁺ respectively. As expected, given the relatively fast rate of the cycloreversion compared to hydrogen exchange in these ionised tricyclic indoles, this fragmentation pattern is similar to that found in the spectra of their unlabelled counterparts, **11** and **12**.

In contrast to the situation in the “6,5,6” series, when the third ring is seven or eight membered, alkyl radical loss becomes important; the spectra of **18** and **19** are dominated by [M-29]⁺ (RI 75) and [M-43]⁺ (RI 100), respectively. These ions can be explained in terms of a 1,4 and 1,5 H-shift to the radical site in the distonic ion formed by cleavage of the third ring. These H-shifts may result in the loss of C₂H₅· and C₃H₇· from **18**⁺ and **19**⁺ respectively, to form a highly delocalised product ion (**t**), Scheme (29) and Figure (4).



Scheme (29): Proposed mechanism for fragmentation of ionised oxocycloalkan[b]indoles with 6,5,5, 6,5,7 and 6,5,8 ring pattern; a) 6,5,5; b) 6,5,8.

The analogous process is not possible for the distonic ions formed from the ionised indoles with a 6,5,6 ring pattern because the required 1,3-H shift is geometrically and energetically unfavourable. Similarly, this mechanism cannot operate for the ionised indoles with a 6,5,5 ring pattern because loss of C_2H_4 leads to an ion with no residual hydrocarbon chain. Although these $[M-C_nH_{2n+1}]^+$ signals complicate the spectra of the indoles with larger third rings, these tricyclic heterocycles are easily distinguished from their isomers with a 6,5,6 pattern. In addition, the spectrum of **19** showed a peak at m/z 184 (RI 13) which could be interpreted as $[M-C_2H_5]^+$. However, loss of a larger alkyl radical (C_3H_7) is more favourable as shown by the ratio ($\sim 1:10$) of the intensity of the peaks at m/z 184 and m/z 170.

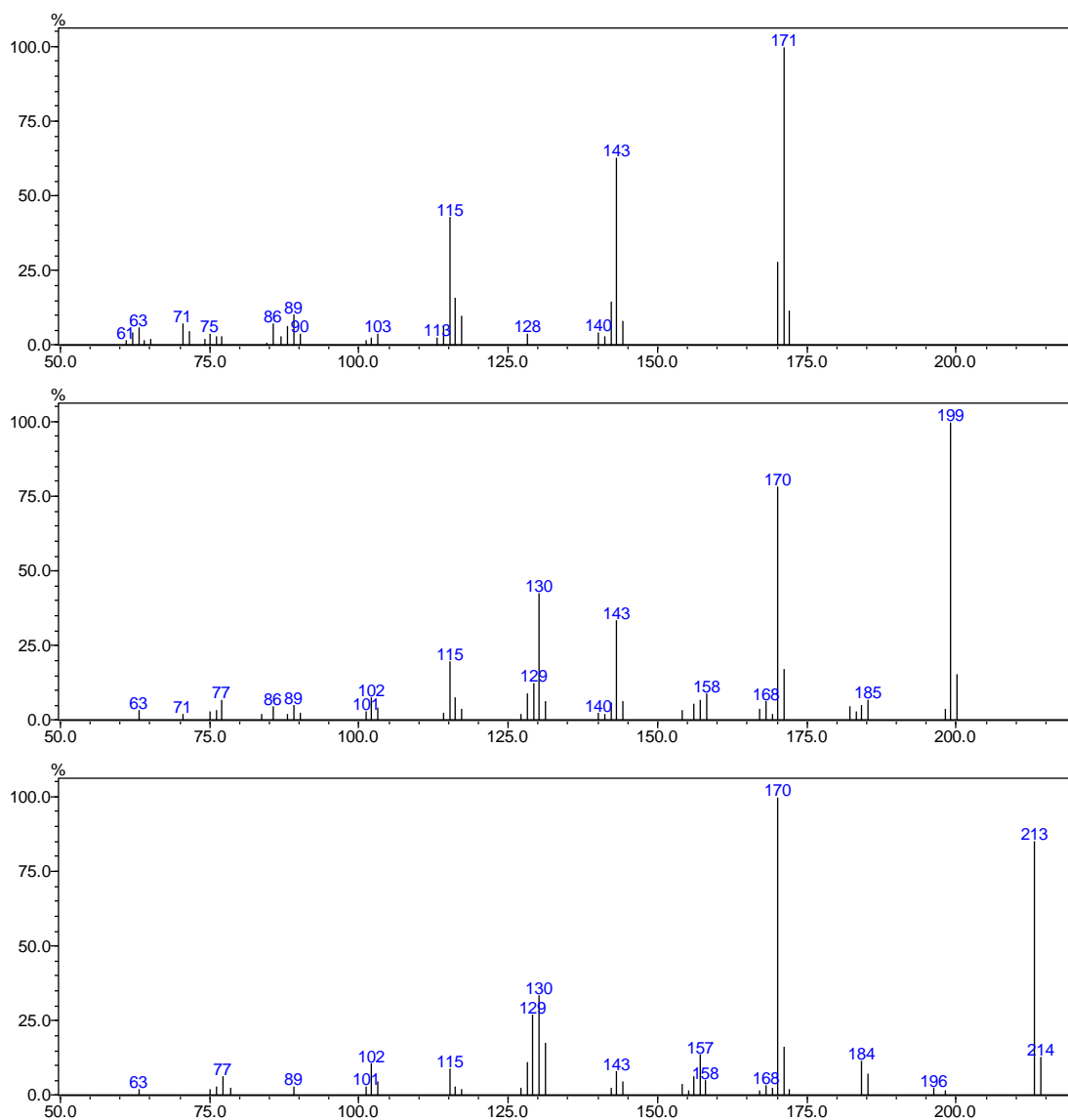

Figure (4): Electron ionisation mass spectra of oxocycloalkan[*b*]indoles with 6,5,5, 6,5,7 and 6,5,8 ring pattern (**17**, **18** and **19**, top to bottom)

Another characteristic feature of the spectra of **17-19** is the peak at m/z 143 which can be formulated as reflecting the formation of (*r*), Scheme (29). These peaks could be interpreted as $[M-C_2H_4]^+$, $[M-C_4H_8]^+$ and $[M-C_5H_{10}]^+$ in the respective spectra of **17-19**; this signal corresponds to fission of two C-C bonds in the original third ring. As with the ionised 6,5,6 tricyclic indoles, **11**, **12**, **15** and **16** the loss of the relevant alkene is followed by a secondary fragmentation by loss of CO, almost certainly by simple cleavage.

Table (3): Important signals in the EI spectra of **17-19**

Compound						Assignments
17		18		19		
m/z	RI ^a	m/z	RI ^a	m/z	RI ^a	
171	100	199	100	213	84	M ⁺
170	29	198	5	212	3	[M-H] ⁺
-	-	184	7	-	-	[M-CH ₃] ⁺
143	65	-	-	-	-	[M-C ₂ H ₄] ⁺
-	-	170	75	184	13	[M-C ₂ H ₅] ⁺
-	-	-	-	170	100	[M-C ₃ H ₇] ⁺
-	-	143	36	-	-	[M-C ₄ H ₈] ⁺
115	43	-	-	-	-	[M-C ₂ H ₄ -CO] ⁺
-	-	-	-	143	9	[M-C ₅ H ₁₀] ⁺
88	6	-	-	-	-	[M-C ₂ H ₄ -CO-HNC] ⁺
-	-	115	20	-	-	[M-C ₄ H ₈ -CO] ⁺
-	-	-	-	115	10	[M-C ₅ H ₁₀ -CO] ⁺
-	-	88	3	-	-	[M-C ₄ H ₈ -CO-HNC] ⁺
-	-	-	-	88	1	[M-C ₅ H ₁₀ -CO-HNC] ⁺

^a RI: relative intensity, measured by peak height and normalised to a value of 100 units for the most intense signal.

Loss of a hydrogen atom (to form [M-H]⁺ at m/z 170, 198 and 212, respectively, from **17⁺**, **18⁺** and **19⁺**) occurs to some extent, especially in the 6,5,5 system (RI 29%). This relatively unusual fragmentation is more noticeable for **17⁺**, in which few other dissociations are geometrically feasible. Once the third ring is larger, however, other processes dominate, including loss of an alkyl radical, as discussed above. A tertiary

fragmentation which is common in the spectra of all these ionised compounds, **11–21** is elimination of HCN after the successive loss of C_nH_{2n} and CO. Loss of HCN is common for ionised nitrogen heterocycles.^{136, 137}

Finally, in this connection, ionised **20** and **21** (the deuterium labelled counterparts of **18** and **19**, respectively) also show a preference for the loss of C_3H_6 (to give m/z 159; RI 93) and C_4H_8 (to form m/z 159; RI 16) rather than $C_3H_4D_2$ (to form m/z 157; RI 3) and $C_4H_6D_2$ (to give m/z 157; RI 9) respectively.

3.2.1.2. Fragmentation of ionised 1-, 2- and 3-oxocyclohexan[b]indoles

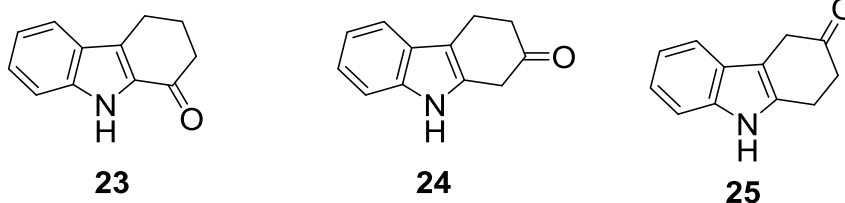

Each of these three isomeric ketoindoles has a characteristically distinctive spectrum, which differs from that of **11**; a common feature, however, is that the M^+ signal is the base peak in each case. The M^+ ion formed from **24** and **25** loses CO, followed by expulsion of C_2H_4 , to give peaks at m/z 157 and 129, respectively, Table (4) and Figure (5). The second most abundant ion in the spectrum of **24**, $[M-42]^+$ (RI 97) may be attributed to loss of ketene ($CH_2=C=O$) from M^+ via a cycloreversion. Similarly, the spectrum of **25** also contains a peak at m/z 143 (RI 22) which could also be interpreted as loss of ketene. However this process is less pronounced for **25**⁺ than for **24**⁺. One explanation for this contrast is that loss of CH_2CO via a two-step mechanism would disturb the aromaticity of the benzenoid ring starting from **25**⁺, whereas the aromaticity of only the heterocyclic ring is

disrupted in the corresponding mechanism starting from **24**⁺, Scheme (30). Regardless of the precise mechanism, these distinctive fragmentations permit **24** and **25** to be distinguished from one other and isomers with a carbonyl group in the 1 or 4 position.

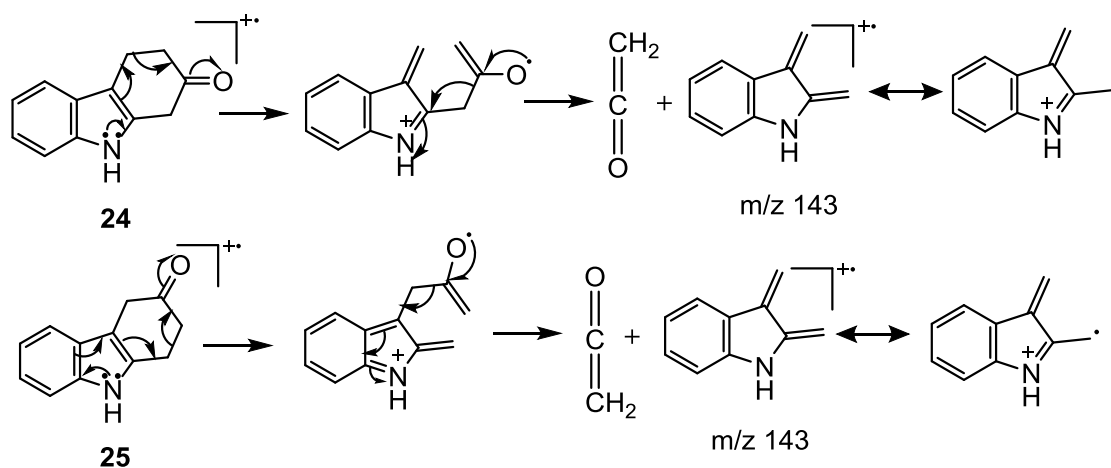

Scheme (30): Proposed mechanism for the loss of ketene from **25**⁺ and **34**⁺

The spectrum of **23** is quite similar to that of **11**. The peaks at m/z 157 and 129 in the spectrum of **23** may be interpreted as $[\text{M}-\text{C}_2\text{H}_4]^+$ and $[\text{M}-\text{C}_2\text{H}_4-\text{CO}]^+$, respectively, as is the case in the spectrum of **11**. However, the $[\text{M}-\text{C}_2\text{H}_4]^+$ signal is stronger in the spectrum of **11**. This contrast can be explained if the cycloreversion is stepwise, Scheme (31).

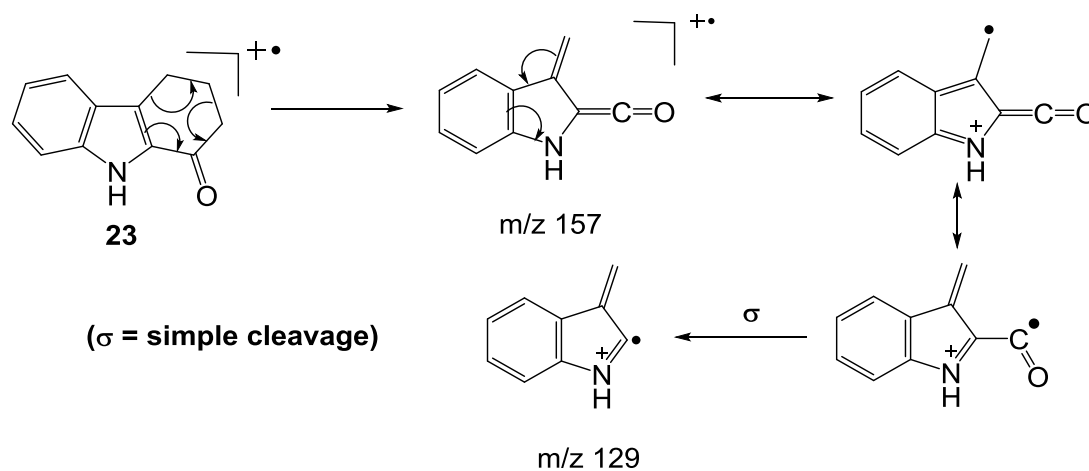

Scheme (31): Proposed mechanism for loss of CO from ionized **23**.

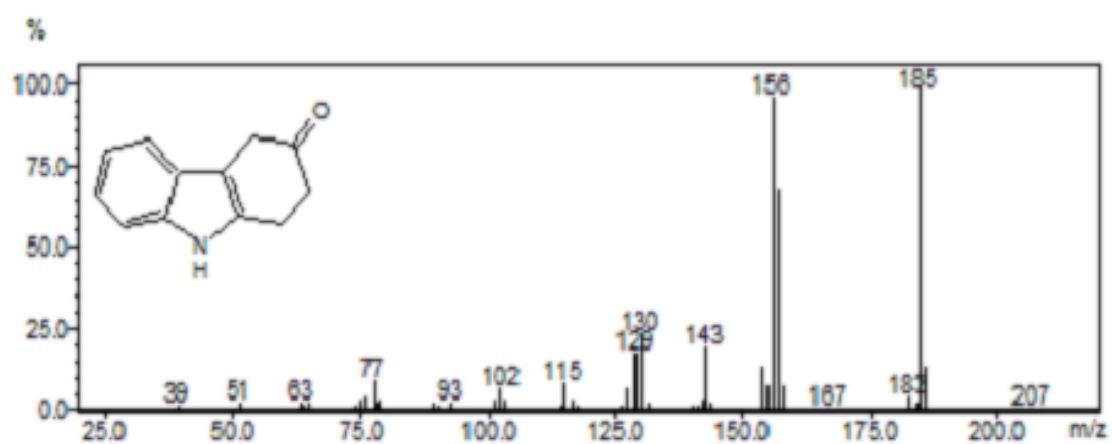
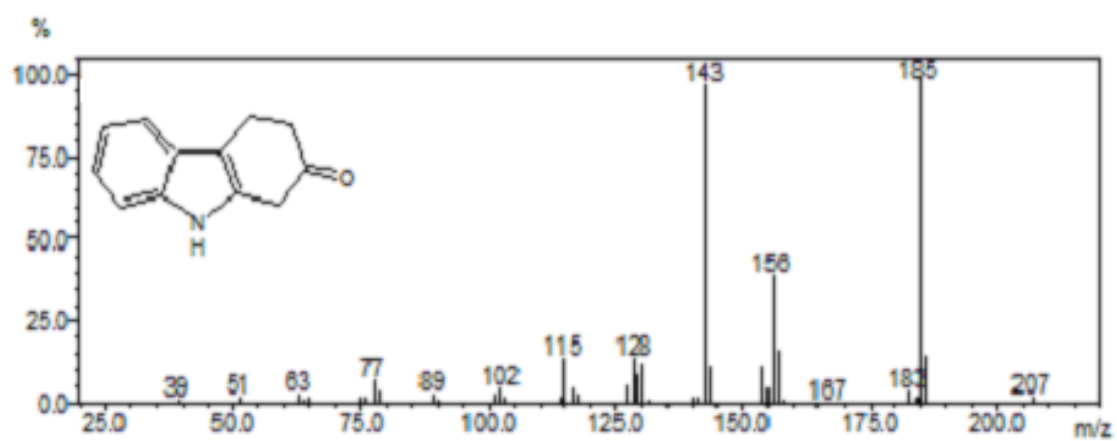
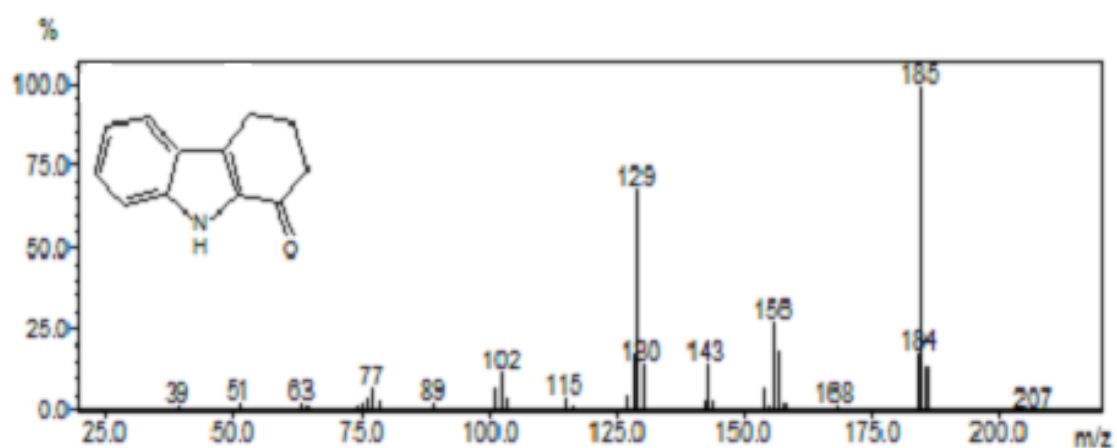

Figure (5): Electron ionisation mass spectra of (top to bottom) **23-25**.

Table (4): Important signals in the EI spectra of **23-25**

Compounds						Assignments
23		24		25		
m/z	RI ^a	m/z	RI ^a	m/z	RI ^a	
185	100	185	100	185	100	M ⁺
184	2	184	17	184	18	[M-H] ⁺
157	16					[M-C ₂ H ₄] ⁺
-	-	157	17	157	68	[M-CO] ⁺
-	-	143	97	143	22	[M-CH ₂ CO] ⁺
129	70	-	-			[M-C ₂ H ₄ -CO] ⁺
		129	12	129	19	[M-CO-C ₂ H ₄] ⁺
102	13					[M-C ₂ H ₄ -CO-HNC] ⁺
		102	3	107	7	[M-CO-C ₂ H ₄ -HNC] ⁺

^a RI: relative intensity, measured by peak height and normalised to a value of 100 units for the most intense signal.

3.2.1.3. Fragmentation of Ionised *n*-cycloalkan[*b*]indoles

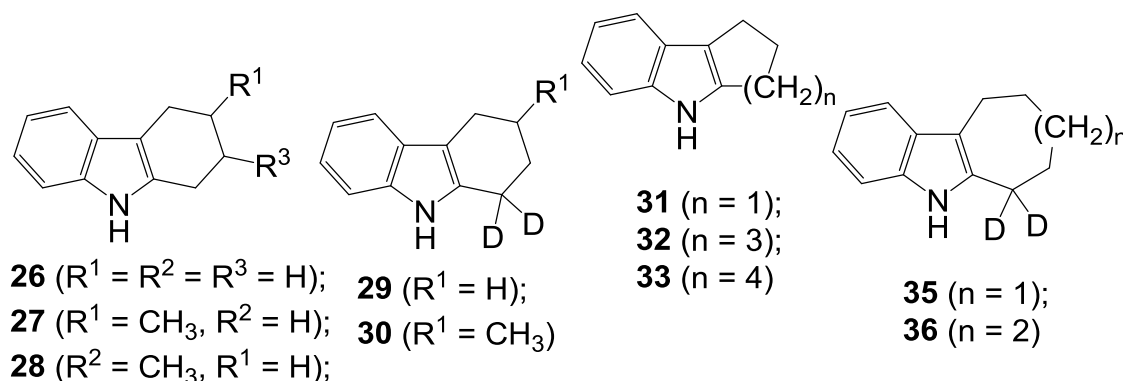

The mass spectra of a set of 10 tricyclic indoles, **26-36**, with various ring patterns have been studied. Each of these compounds shows an intense M⁺ signal in its mass spectrum (RI ≥ 50%, with M⁺ giving rise to the base peak in the spectrum of **31-33**). The most intense peak in the spectra of **26-28** is at m/z 143. In general, these unfunctionalised ionised tricyclic indoles fragment in similar ways to their functionalised counterparts (**11⁺-21⁺**) with a carbonyl group in the third ring.

One significant difference between the spectra of the functionalised and unfunctionalised tricyclic indoles is the presence in the spectra of **26-33**, **35-36** of peaks corresponding to $[M-1]^+$ ions which were either not seen or else were of minor importance in the spectra of the **11-14** and **17-19**, Tables (5) and (6). As indicated in the brief statement concerning this peak in the spectrum of the 6,5,5 ketoindole, where it is of moderate intensity, the corresponding ion may be attributed to loss of hydrogen atom from the third ring to give a stable delocalised cation shown as ion (**u**), Scheme (32).

The base peak in the spectra of **26-28**, occurring at m/z 143, may be attributed to loss of alkene by a cycloreversion. In the spectrum of **26**, this results in the loss of C_2H_4 , whereas **27⁺** and **28⁺** lose C_3H_6 to give the homologous ion (**v**), Scheme (32).

Table (5): EI mass spectra of *n*-cycloalkan[*b*]indoles, **26-28**

26		27		28		Assignment
m/z	RI ^a	m/z	RI ^a	m/z	RI ^a	
171	64	185	52	185	62	M^+
170	19	184	6	184	13	$[M-H]^+$
143	100	-	-	-	-	$[M-C_2H_4]^+$
-	-	143	100	143	100	$[M-C_3H_6]^+$

^a RI: relative intensity, measured by peak height and normalised to a value of 100 units for the most intense signal

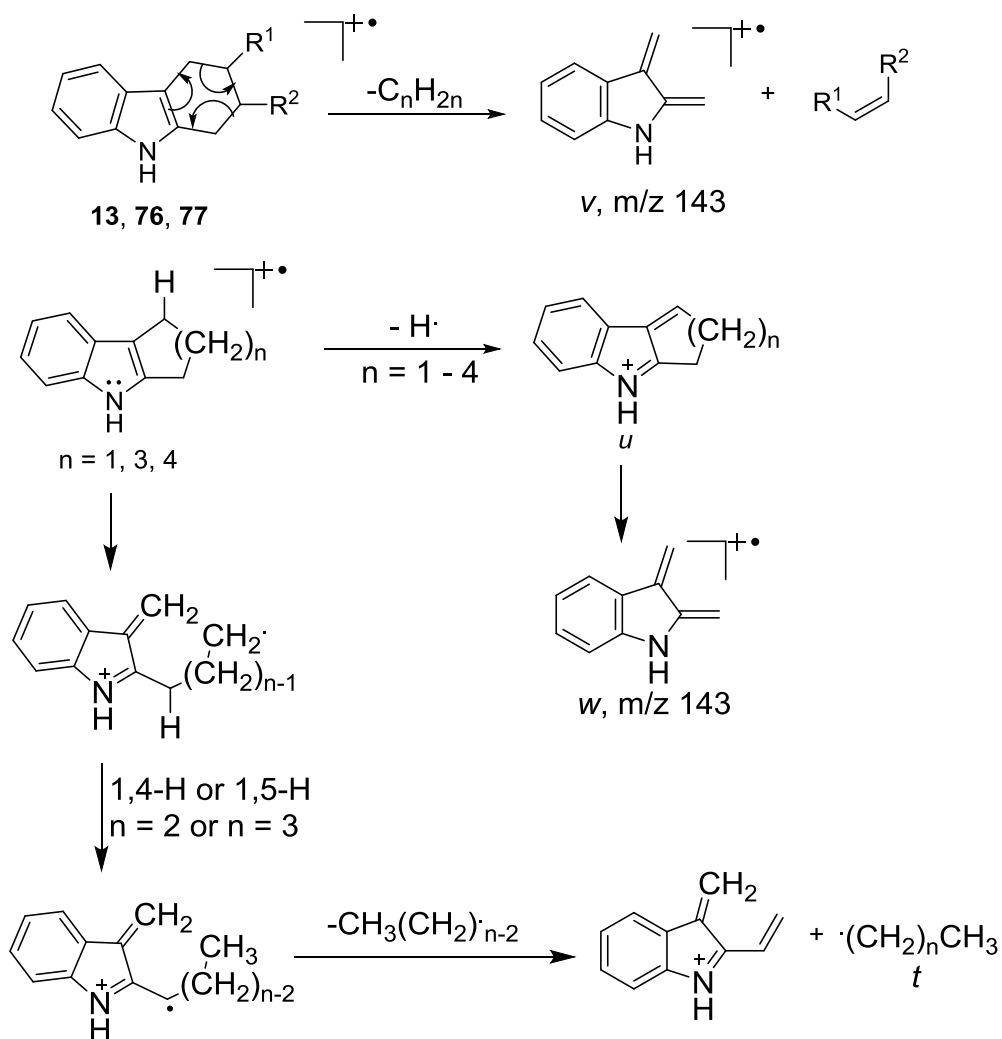

Scheme (32): Proposed mechanism for fragmentation of ionised *n*-cycloalkan[*b*]indoles, **26-33**, **35-36**.

The spectra of **31-33** exhibit peaks corresponding to $[M-28]^+$, $[M-42]^+$ and $[M-56]^+$, respectively; these signals correspond to an ion of m/z 143 that can be depicted as (*w*). In the case of **31**, C_2H_4 is lost, whereas C_3H_6 and C_4H_8 , respectively, are eliminated from **32**⁺ and **33**⁺. In addition, the spectra of the “6,5,7” and “6,5,8” tricycles contain major peaks corresponding to the loss of an alkyl radical ($\cdot C_2H_5$ and/or $\cdot C_3H_7$). These important peaks can be interpreted by mechanisms involving fission of the third ring in the ionised indole, followed by a 1,4 and 1,5 H-shift in the resultant alkyl chain, with eventual loss of an alkyl radical from this incomplete hydrocarbon chain to

give ion (**x**), Scheme (**32**), at m/z 156. A parallel process, with eventual retention of an extra carbon atom in the fragment ion, accounts for the formation of a similar ion at m/z 170 by loss of a smaller alkyl radical, Table (**6**).

Table (**6**): EI mass spectra of *n*-cycloalkan[*b*]indoles, **31–33**

31		32		33		Assignment
m/z	RI ^a	m/z	RI ^a	m/z	RI ^a	
157	100	185	100	199	100	M ⁺
156	97	184	61	198	23	[M-H] ⁺
129	23	-	-	-	-	[M-C ₂ H ₄] ⁺
-	-	156	73	170	46	[M-C ₂ H ₅] ⁺
	-	143	33	-	-	[M-C ₃ H ₆] ⁺
-	-	-	-	156	72	[M-C ₃ H ₇] ⁺
-	-	-	-	143	62	[M-C ₄ H ₈] ⁺

^a RI: relative intensity, measured by peak height and normalised to a value of 100 units for the most intense signal

As is the case with the ionised 4-oxocyclohexan[*b*]indoles, the analogous 1,3-H-shift is not possible for the ring-opened isomers of the ionised tetrahydrocarbazoles, **26–28**, because it would entail undesirable geometric constraints which are energetically unfavourable. Thus the spectra of these 6,5,6 heterocycles do not show appreciable signals corresponding to loss of an alkyl radical.

3.3. Vibrational spectra of Tricyclic Indoles

3.3.1. Infrared and Raman Spectra of *n*-oxocycloalkan[*b*]indoles

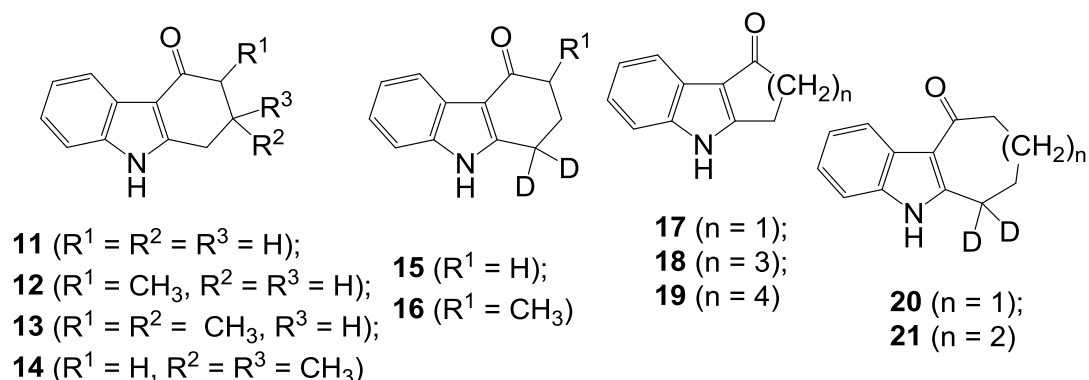

C=O, N-H, O-H and C=N vibrations

It has been well-known for many years that compounds containing a carbonyl functional group show a characteristic and strong C=O absorption in their IR spectra in the range $1850\text{--}1550\text{ cm}^{-1}$.¹³⁸⁻¹⁴⁰ Moreover, the wavenumber of the C=O stretching band is systematically influenced by the substituent(s) attached to the carbonyl group and the size of the ring if the compound is cyclic. Electron donating groups and conjugation lowers this wavenumber; in contrast, electron withdrawing groups increase the wavenumber, as does ring strain (in a five- or four-membered ring);¹¹ these points have been reiterated more recently. The band corresponding to this vibrational mode is stronger in the IR than Raman owing to the strong dipole moment of the C=O group. Similarly, the IR spectrum of an alcohol or phenol usually shows a band in the $3650\text{--}2500\text{ cm}^{-1}$ region that may be assigned to the O-H stretching mode; moreover, hydrogen bonding usually reduces the wavenumber and increases the width of this band, which is typically strong.

In the case of the parent tricyclic indole, **11**, which was described in the early literature as a ketoindole,¹⁰² the absence of a strong band around 1700 cm⁻¹ in the IR spectrum is at first sight rather surprising. A band is present in the FT-IR spectrum of **12** at 1603 cm⁻¹; however, this wavenumber is extremely low for a C=O stretching mode of a six-membered ring ketone. Furthermore, the higher wavenumber region of the spectrum of **11** does not contain the diagnostic strong and sharp band above 3200 cm⁻¹ that is typical for the N-H stretching vibration of an indole N-H group;^{139, 141-143} instead, a very broad band is present at 3280-2800 cm⁻¹. It appears natural to deduce from these aspects of the IR spectrum that **11** exists as the hydroxyindolenine tautomer (with the bands at 3280-2800 and 1603 cm⁻¹ ascribed to the O-H (H-bonded) and C=N stretching vibrations, respectively). The production of **11** as a hydroxyindolenine, instead of the apparently more stable ketoindole tautomer, might be favoured by the more extensive conjugation of the monophenylhydrazone enol intermediate that is involved in the synthesis of **11** from the precursor cyclohexane-1,3-dione. On the other hand, the solid state IR spectra of 3-acetylindole and indole-3-carboxaldehyde contain C=O stretching bands at unusually low wavenumber at 1614 and 1631 cm⁻¹, respectively; in addition, abnormally broad N-H stretching bands are present in these spectra.¹⁴⁴ Parallel trends have been observed for a number of pyrroles, in which a C=O group directly attached to the heteroaromatic nucleus does not display either the chemical or spectroscopic properties that are normally associated with a simple carbonyl compound.¹⁴⁵

The appearance of IR spectra sometimes varies drastically with the conditions (solid state or solution) under which they are recorded. Therefore, the spectra of **11** and related compounds were recorded both in the solid state and in solution. In order to obtain further insight into this intriguing aspect of the tautomerism of these heterocycles, computational modelling was carried out to determine the stability of the ketoindole and hydroxyindolenine tautomers. These computational data have the advantage of replicating the structures and energetics of the tautomers free from the influence of solvent effects or intermolecular hydrogen bonding.

Before presenting a survey of the IR spectra of these heterocycles, it is necessary to address the issue of whether these compounds are ketoindoles or hydroxyindolenines, Figure (6) shows the IR spectrum of **11** recorded in solution in chloroform and in the solid state.

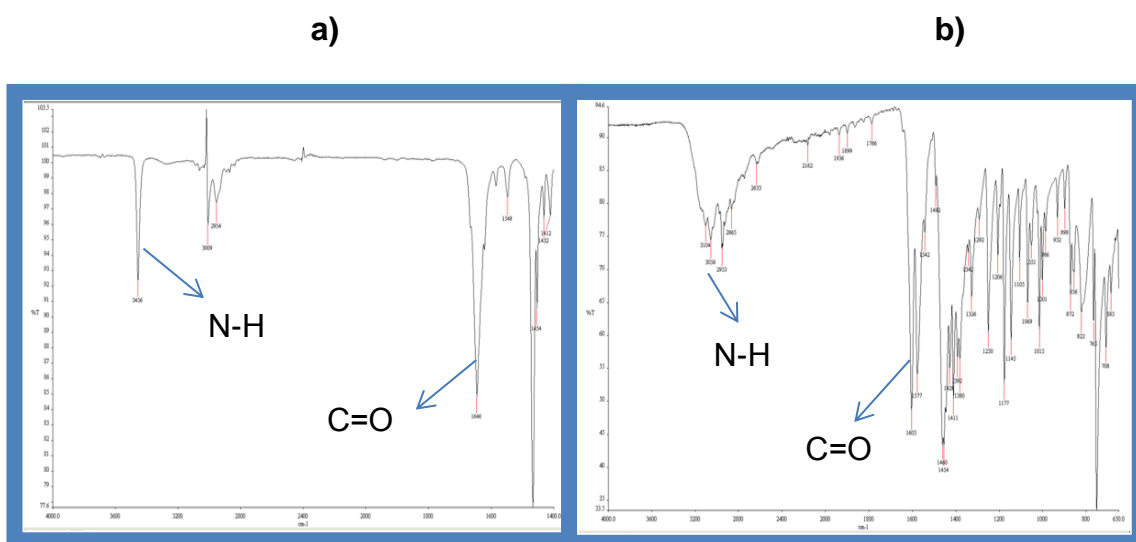

Figure (6): IR spectrum of **11**; a) in solution in CHCl₃, b) solid.

The differences between these two spectra are striking. In the solid state, hydrogen bonding (between the N-H and the C=O, to form strong N-H-

---O=C linkages) is extremely important, leading to a great reduction in the wavenumber of both the N-H and C=O stretching bands. Indeed, this spectrum gives the impression that the compounds are hydroxyindolenines, which show broad O-H and relatively strong C=N vibrational stretching bands. However, in chloroform solution, where intermolecular hydrogen bonding is broken down by intervening solvent molecules, the usual sharp N-H and strong C=O stretching bands at 3456 and 1646 cm^{-1} , respectively, are clearly seen (admittedly at rather low wavenumber for the heavily conjugated “vinylogous” carbonyl group). These results and interpretation are in good agreement with previous studies on **11** and related systems.¹⁰⁴

The divergent appearance of these two spectra raises a further issue: if the hydrogen bonding is as powerful as it appears to be, the distinction between a ketoindole (in which the bridging hydrogen is more closely associated with the C=O group) and the tautomeric hydroxyindolenine (in which it is nearer to the N-H group) has been blurred. This point must be kept clearly in mind when analysing the vibrational spectra of these interesting heterocycles, especially if the spectra are recorded in the solid state, rather than in solution. The ketoindole nature of **11** and related heterocycles is much more easily discerned if their IR spectra are recorded in solution.

Table (8) shows the relative energies of the ketoindole and hydroxyindolenine tautomers of **11** as calculated by computational methodology at two levels of theory (PBE and B3LYP) in the absence of solvent and in chloroform. The results presented do not incorporate thermal, zero-point or entropic corrections as they were found to be small.

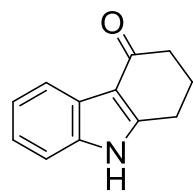

Tautomer **11a**

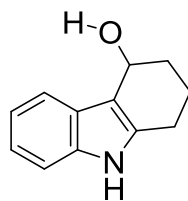

Tautomer **11b**

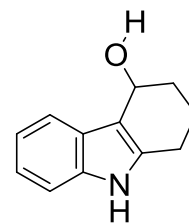

Tautomer **11c**

Table (8): Calculated total and relative energies of the tautomers and their conformers

Solvent	Method	Total Energy (Hartree)			Relative Energy of Tautomer 11b/c to Tautomer 11a (kJ/mol) ^a	Relative Energy of Tautomer 11c to Tautomer 11b (kJ/mol)
		Tautomer 11a	Tautomer 11b	Tautomer 11c		
No Solvent	PBE	-593.3715349	-593.3472577	-593.3443215	63.7	7.7
	B3LYP	-593.7471889	-593.7219985	-593.7194108	66.1	6.8
Chloroform	PBE	-593.3851621	-593.3591019	-593.3590604	68.4	0.1
	B3LYP	-593.7610463	-593.7340077	-593.7342118	70.4	-0.5

^aThe relative energy is the energy of the lowest energy conformer of Tautomers **11b** and **11c** above the energy of Tautomer **11a**.

These computational data indicate that the ketoindole tautomer, **11a**, is more stable than the lowest energy conformer of the hydroxyindolenine tautomer, **11c**, by at least 63 kJ mol⁻¹, Table (8). Moreover, the data also reveal that the greater stability of the ketoindole tautomer is enhanced in solution (chloroform). The predicted IR spectrum of keto indole tautomer in the gas phase shows a strong band at 1657 cm⁻¹ which corresponds to the C=O stretch and is in good agreement with the wavenumber of the experimental band in the solution spectrum reported in this study and in previous work.¹⁰⁴ The spectra of three conformers of **11** as predicted from computational modelling are shown in Figure (7).

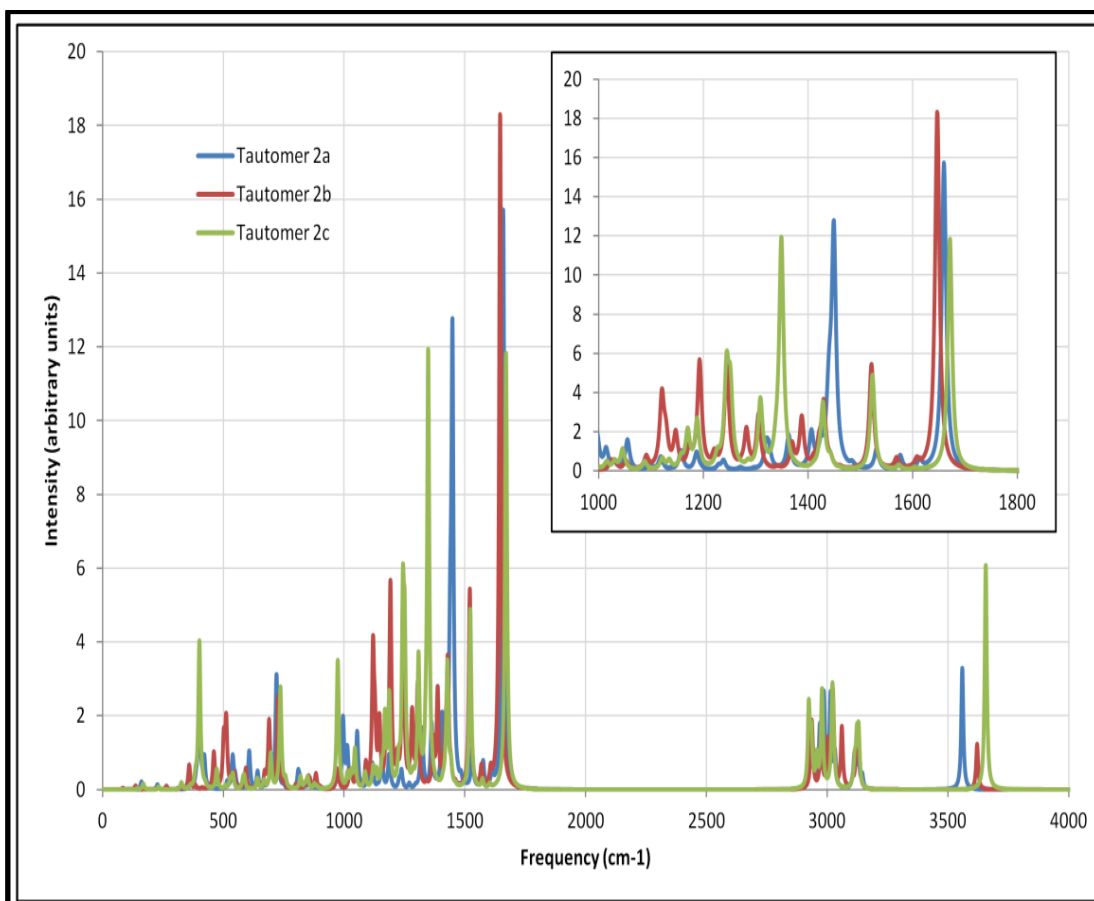

Figure (7): Computationally modelled IR spectra of three tautomers of **11**

Important bands in the IR spectra (recorded in the solid state) of the set of indoles, **11-16**, are summarised in Table (9). The following points are evident. Firstly, the IR spectra of **12**, **13** and **14**, which are higher homologues of **11** containing one or two methyl groups in positions 3 or 2 of the third ring, closely resemble that of the parent **11** in showing a very broad N-H stretching band in the range 3300-2400 cm^{-1} and an extremely low wavenumber C=O stretching band in the range 1625-1603 cm^{-1} . Parallel trends are apparent in the spectra of **15** and **16**, which are analogues of **11** and **12**, respectively, with a CD_2 group instead of a CH_2 group in position 1 of the third ring. Thus, the strong absorption bands observed at 1625, 1625, 1606, 1603 and 1616 cm^{-1} in the FT-IR spectra of **12**, **13**, **14**, **15** and **16**,

respectively were assigned to the C=O (conjugated) stretching vibration mode. The corresponding C=O stretches appeared in the FT-Raman at the same region but of much lower intensities, Table (9) and (10) and Figure (8) and (9), as would be expected because this vibrational mode is far less active in Raman than in IR spectroscopy.

Table (9): Important bands in the FT-IR spectra^a of 11-16

Wavenumber (cm ⁻¹) and intensity ^b						Proposed Assignment ^c
11	12	13	14	15	16	
3260-2800(b) ^d	3280-2400(b) ^d	3260-2800(b) ^d	3240-2800(b) ^d	3200-2800(b) ^d	3280-2800(b) ^d	v(N-H)
3056(w)	3081(w)	3066(w)	3056(w)	3056(m)	3054(s)	v(C-H) sp ²
2953(w)	2990(w) 2923(m) 2858(m)	2954(w) 2927(w) 2870(w)	2956(m)	2953(m) 2926(m) 2862(m)	2927(m) 2853(m)	v(C-H) sp ³
-	-	-	-	1937(w) 1900(w)	2183(w) 2044(w)	v(C-D) sp ³
1603(s)	1625(s)	1625(s)	1606(s)	1603(s)	1617(s)	v(C=O)
1577(s)	1615(s)	1614(s)	1576(m)	1575(s)	1582(m)	δ(N-H)
1542(m)	1581(s)	1583(s)	1539(m)	1539(m)	-	v(C=C) benzene ring
1454(s)	1450(s) ^e	1465(s) ^e	1465(s)	1451(s)	1449(s)	v(C=C) 5- membered ring of indole
1428(m) 1411(s)	1393(w) 1380(m)	1445(s) 1405(w)	1408(m) 1370(m)	-	1371(m) 1353(m)	δ(CH ₂)
	1371(s)	1384(s)	1328(s)	-	1319(m)	δ(CH ₃)
1326(m)	1328(s)	1323(m)	1350(m)	1317(m)	1298(m)	v(C-N)

^a Spectra were recorded in the solid state. ^b Qualitative classification of the intensity as follows: w (weak), m (medium), s (strong), v (very), br (broad); v (stretch), δ (deformation). ^c Some assignments are necessarily tentative, particularly in the low wavenumber region of the spectra. ^d very broad bands. ^e very strong bands

Table (10): Important bands in the Raman spectra^a of **11-13**, **15-16**

Wavenumber(cm ⁻¹) and intensity ^c					Proposed Assignment ^f
11	12	13	15	16	
3379(w)	3348(w) ^d	-	3377(w) ^d	-	v(N-H)
3061(m)	3062(m)	3072(m)	3051(s)	3060(m)	v(C-H) sp ²
2946(s)	2933(m)	2933(s)	2936 (s)	2956(w)	v(C-H) sp ³
2884(s)	2902(m)	2902(m)	2907(m)	2930(m)	
2863(m)	2963(m)	2863(m)	2884(m)	2860(m)	
			2852(m)		
-	-	-	2186(m) 2146(m) 2126(m) 2097(m) 2058(m)	2142(m)	v(C-D) sp ³
1664(w)	1688(w)	1620(m)	1610(w)	1629(m)	v(C=O)
1605(s) ^e	1628(s) ^e	1599(s) ^e	1584(s)		v(C=C) benzene ring
1490(m)	1493(m)	1487(m)	1467(m)	1460(s)	v(C=C) 5-membered ring of indole
1576(m)	1542(s)	1579(m)	1563(m)	1542(m)	δ(N-H)
1459(s)	1461(s) 1422(m)	1446(s) 1425(s)	1446(m) 1422(w)	1384(m)	δ(CH ₂)
-	1383(m)	1391(m)	-	1333(m)	δ(CH ₃)
1328(m)	1339(m)	1342(m)	1360(m)	1364(w)	v(C-N)

^a Spectra were recorded in the solid state. ^b Discolouration of **24** occurred so rapidly that it was not possible to secure a high-quality Raman spectrum. ^c Qualitative classification of the intensity as follows: w (weak), m (medium), s (strong), v (very), br (broad); v (stretch), δ (deformation). ^d very weak bands. ^e very strong bands. ^f Some assignments are necessarily tentative, particularly in the low wavenumber region of the spectra.

(a)

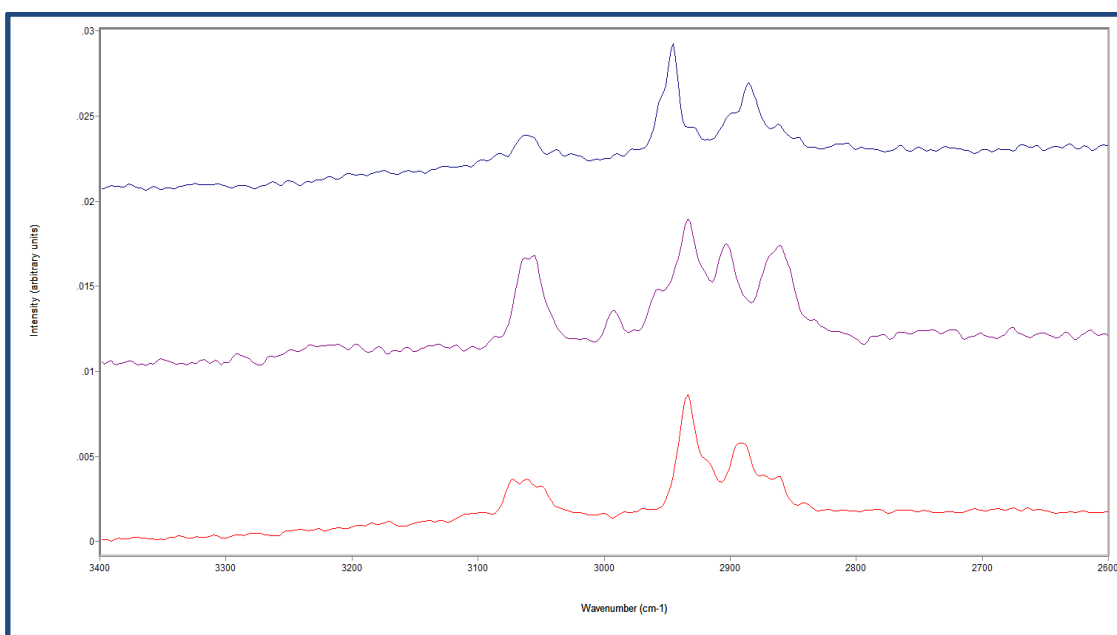

(b)

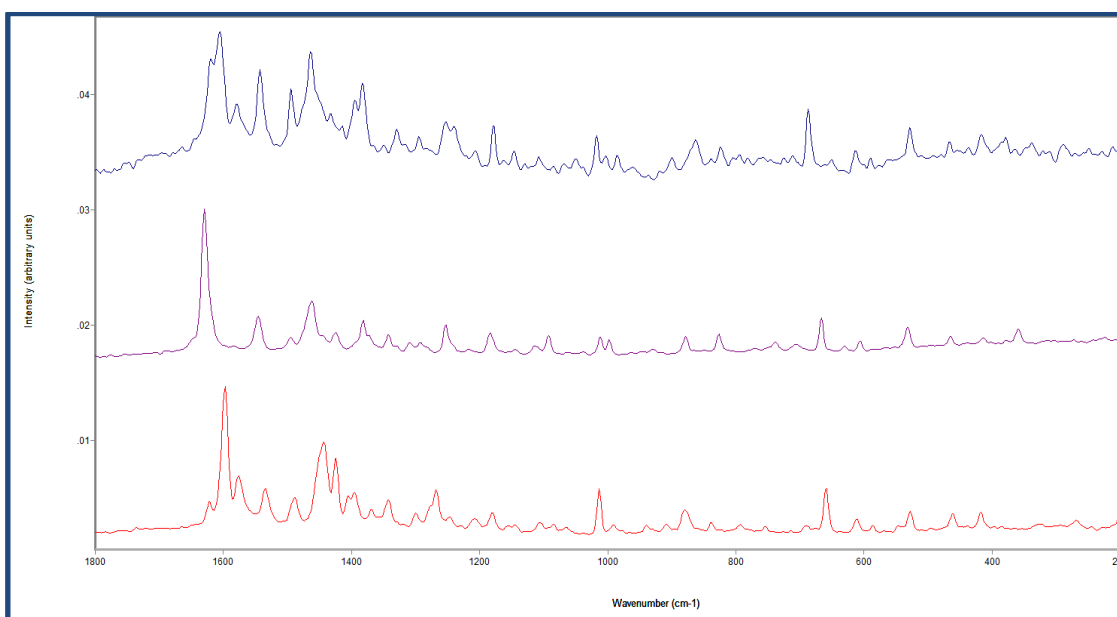
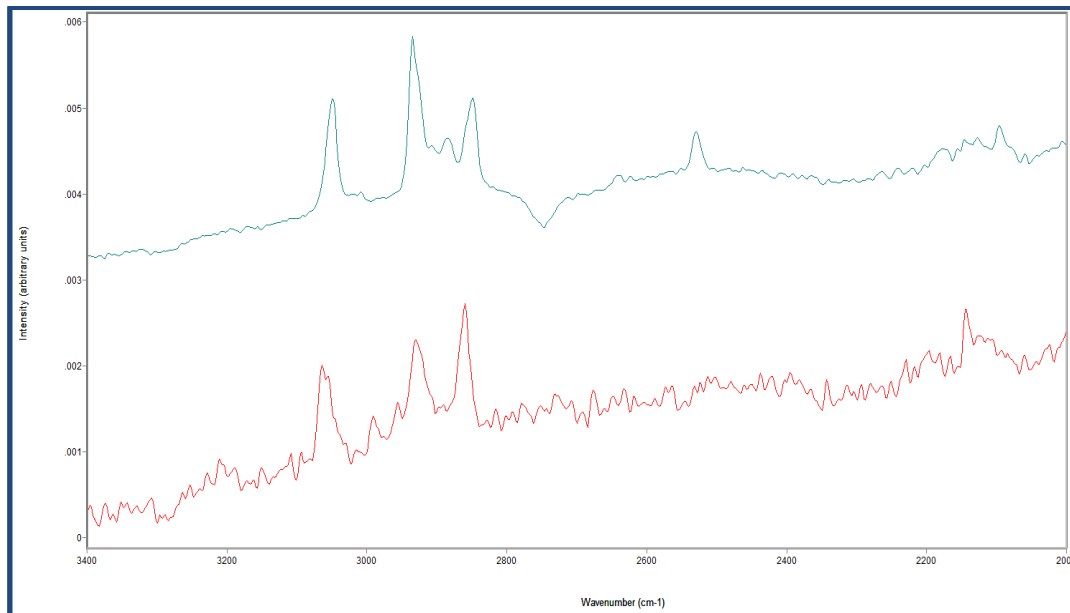

Figure (8): Raman spectra of 4-oxocyclohexan[*b*]indoles, **11**, **12** and **13** (top to bottom); (a) 3400–2600 cm⁻¹ and (b) 1800–200 cm⁻¹ region.

These trends show that the powerful conjugation of the NH-C=C-C=O entity in these compounds, coupled with strong intermolecular hydrogen bonding involving the C=O and N-H groups of adjacent molecules,

profoundly affects the structure and vibrational spectroscopic properties of these compounds.

(a)



(b)

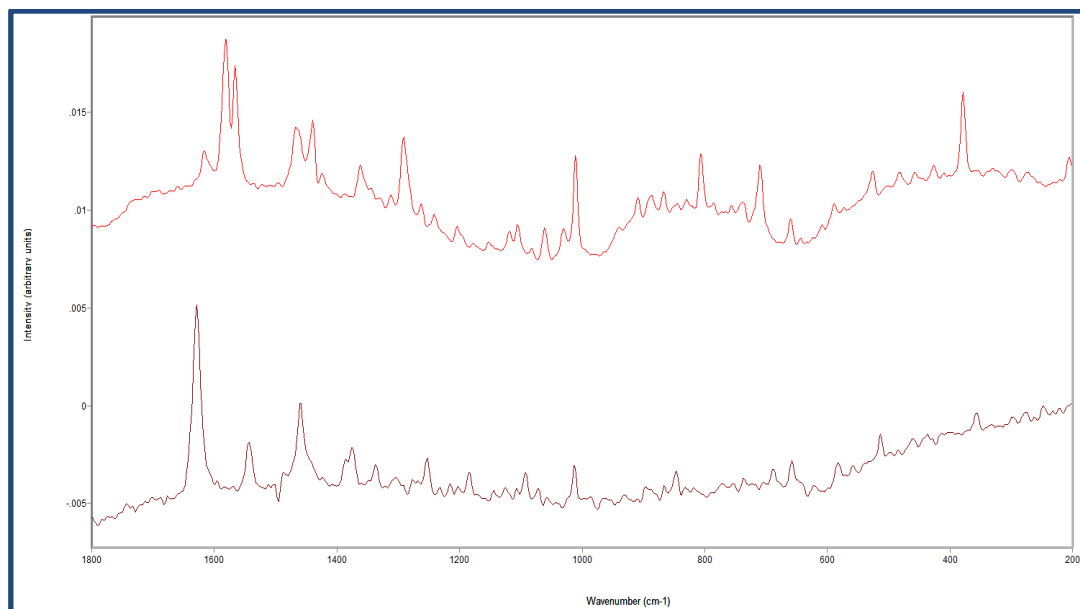

Figure (9): Raman spectra of deuterium labelled 4-oxocyclohexan[*b*]indoles **15** and **16** (top to bottom); (a) 3400–2600 cm⁻¹ and (b) 1800–200 cm⁻¹ region.

Table (11): Important bands in the Infrared spectra^a of **17-21**

Wavenumber (cm ⁻¹) and intensity ^b					Proposed Assignment ^c
17	18	19	20	21	
3260– 2800(b) ^d	3200– 2800(b) ^d	3200– 2740(b) ^d	3280– 2800(b) ^d	3280– 2800(b) ^d	$\nu(\text{N-H})$
3033(w)	3045(w)	3089(m)	3097(m) 3042(m)	-	$\nu(\text{C-H}) \text{ sp}^2$
2934(w)	2971(m) 2931(m) 2862(m)	2942(m) 2925(m) 2851(m)	2931(m) 2863(m)	2943(m) 2926(m) 2852(m)	$\nu(\text{C-H}) \text{ sp}^3$
-	-	-	2163(w) ^f	2200(w) ^f	$\nu(\text{C-D}) \text{ sp}^3$
1650(s)	1596(s)	1603(s)	1596(s)	1602(s)	$\nu(\text{C=O})$
1614(s)	1573(s)	1576(s)	1572(s) ^e	1575(s)	$\nu(\text{C=C})$ benzene ring
1450(s)	1423(s) ^e	1443(s) ^e	1425(s) ^e	1437(s) ^e	$\nu(\text{C=C})$ 5-membered ring of indole
-	1486(m)	1487(m)	-	-	$\delta(\text{N-H})$
1451(s) 1429(s)	1404(s)	1476(m)	1486(m) 1406(s) ^e	1486(w) 1376(m)	$\delta(\text{CH}_2)$
-	1367(s)	1375(s)	1178(s)	1040(s)	$\nu(\text{C-N})$

^a Spectra were recorded in the solid state. ^b Qualitative classification of the intensity as follows: w (weak), m (medium), s (strong), v (very), b (broad); ν (stretch), δ (deformation). ^c Some assignments are necessarily tentative, particularly in the low wavenumber region of the spectra. ^d very broad bands. ^e very strong bands. ^f very weak bands

A few cases have been reported where the normally less stable indolenine tautomer has been shown to be the dominant form at equilibrium (for instance 2-piperidinoindole).¹⁴⁶ However, despite the absence of obvious bands at the usual wavenumber associated with the normally strong C=O and N-H stretching vibrations in solid state IR spectra, the superficially attractive deduction that these tricyclic heterocycles exist as hydroxyindolenines is, at best, an oversimplification. A careful analysis of the spectroscopic and computational data indicates that **11-14** and **18-21** exist mainly as ketoindoles rather than the corresponding hydroxyindolenines, as

is revealed by their IR spectra obtained in solution. Nevertheless, it is also clear that the distinction between ketoindoles and hydroxyindolenines is less obvious than may appear at first sight.

3.3.2. Infrared and Raman of 1-, 2- and 3-oxocyclohexan[*b*]indoles

The three isomers of compound **11** with a keto group in a different position in the third ring may now be discussed in more detail; relevant spectra are summarised in Table (13) and illustrated in Figure (10). The spectra of **24** and **25**, in which the carbonyl group is in position 3 and 2, respectively, of the third ring, differ substantially from those of their isomer, **11**. The high wavenumber regions of the FT-IR spectra of **24** and **25** are dominated by the strong and sharp N-H stretching band at 3382 and 3391 cm^{-1} , respectively, that is typically found for indoles. Similarly, a strong and quite sharp C=O stretching band appears at a wavenumber of 1704 and 1708 cm^{-1} , respectively, which differs only slightly from that (1716 cm^{-1}) associated with the C=O stretching mode of cyclohexanone (recorded as a liquid film). These diagnostic changes, which may be logically attributed to the absence of the powerful conjugation between the NH and C=O groups that is present in **11**, permit indoles with a carbonyl group in position 3 or 2 to be readily distinguished from their isomers in which the carbonyl group is in position 4.

Table (13): Important bands in the Infrared and Raman spectra^a of **23-25**

Wavenumber(cm ⁻¹) and intensity ^b						Proposed Assignment ^c
23		24		25		
IR	Raman	IR	Raman	IR	Raman	
3270(s)	3368(w)	3391(s)	3359 (w)	3382(s)	3382(w)	v(N-H)
	3057(w)	3058(w)	3052 (s)	3054(w)	3057(s)	v(C-H) sp ²
2931(m)	2939(m)	2958(w)	2942(s)	2966(w)	2965(s)	v(C-H) sp ³
2861(w)	2901(m)	2927(w)	2927(s)	2918(w)	2947(s)	
		2889(w)	2827(s)		2918(s)	
		2862(w)	2860(s)		2895(s) 2860(s)	
1636(s)	1704(w)	1708 (s)	1704(m)	1704(s)	1701(m)	v(C=O)
1616(s)	1629(s)	1622(m)	1591(s)	1624(w)	1594(vs)	v(C=C) benzene ring
1473(m)	1493(m)	1465(m)	1495(m)	1456(w)	1466(m)	v(C=C) 5- membered ring of indole
1571(m)	1574(w)	1590(m)	1568(m)	1584(w)	1571(m)	δ(N-H)
1441(m)	1475(m)	1448(s)	1464(m)	1436(m)	1455(m)	δ(CH ₂)
1408(m)	1437(m)	1423(m)		1409(m)	1408(m)	
1327(m)	1374(m)	1363(m)	1374(m)	1329(s)	1371(m)	v(C-N)

^a Spectra were recorded in the solid state. ^b Qualitative classification of the intensity as follows: w (weak), m (medium), s (strong), v (very), br (broad); v (stretch), δ (deformation). ^c Some assignments are necessarily tentative, particularly in the low wavenumber region of the spectra.

The high wavenumber regions of the FT-IR spectra of **24** and **25** also contain rather weak bands at 3058 and 3054 cm⁻¹, corresponding to sp² C-H

stretching vibrations. A number of weak bands between 2966 and 2860 cm^{-1} were similarly assigned to the sp^3 C-H stretches.

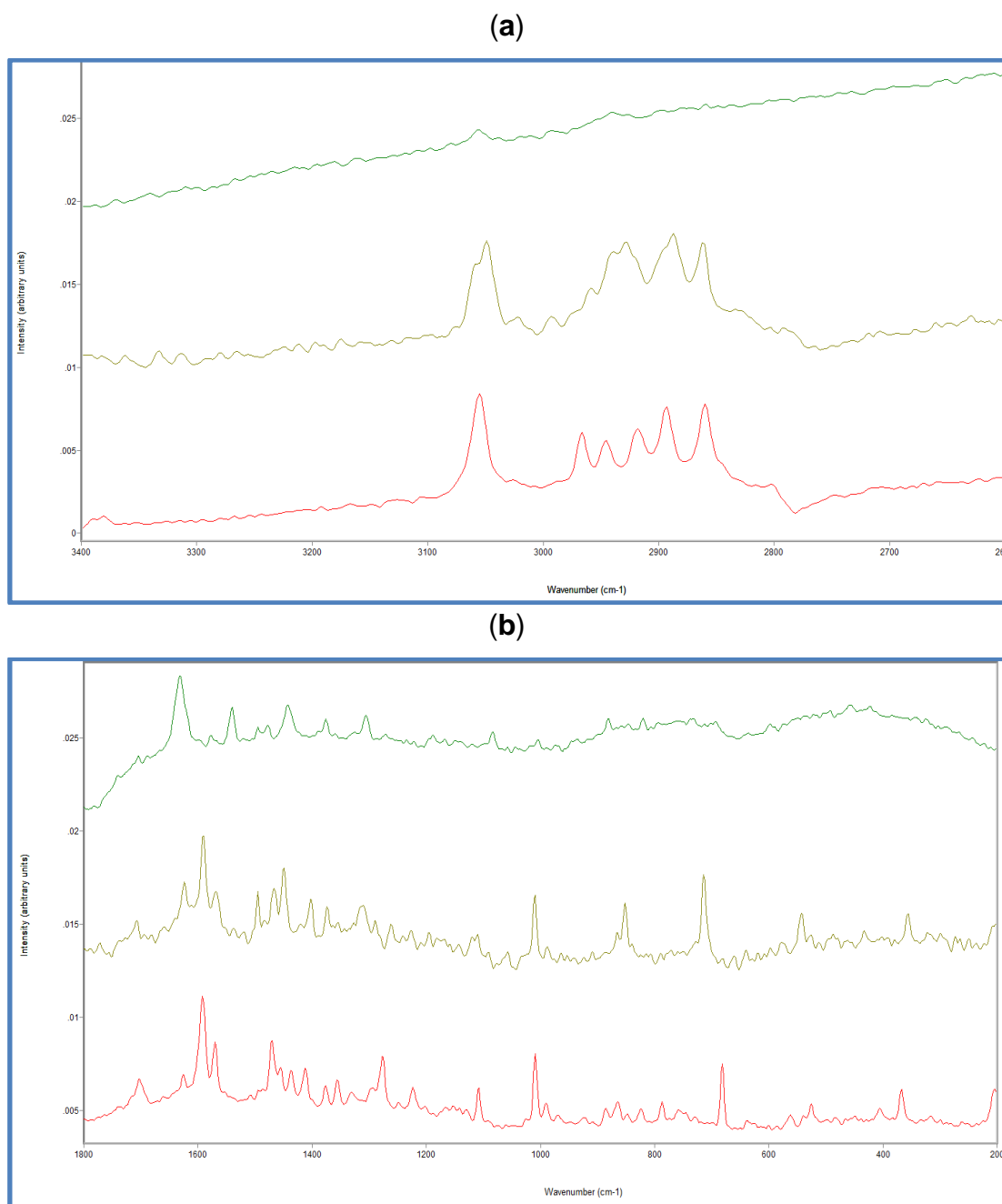

Figure (10): Raman spectra of 1, 2 and 3-oxocyclohexan[*b*]indoles, **23**, **24** and **25** (top to bottom); (a) 3400–2600 cm^{-1} and (b) 1800–200 cm^{-1} region.

Four significant bands of medium intensity are present at 1622, 1590, 1465 and 1363 cm^{-1} in the IR spectrum of **24**. These bands could be assigned to $\nu(\text{C}=\text{C})$ benzene ring quadrant, $\delta(\text{N-H})$, $\nu(\text{C}=\text{C})$ of the 5-

membered ring of indole and $\nu(\text{C-N})$, respectively, Table (13). In addition, the spectrum of **25** shows bands at similar positions, which were interpreted in the same fashion.

In comparison with the other isomers with a 6,5,6 ring pattern, the IR spectrum of **23**, in which the carbonyl group is in position 1, differs from that of either **11** or **24** and **25**. There is a distinctive strong and sharp N-H stretching band at 3270 cm^{-1} , but it appears at a significantly lower wavenumber than the corresponding band in the spectrum of **24** and **25**. In this respect, the spectrum of **17** appears to resemble those of **24** and **25** more closely than that of **11** (or **12-16**) in showing a band attributable to the normal N-H stretching mode of indoles. On the other hand, the appearance of the C=O stretching band, which is broad and at rather low wavenumber (1636 cm^{-1}), suggests that conjugation between the NH and C=O, although not quite as effective as is the case in **11**, remains very powerful, thus weakening the C=O bond and reducing its vibrational wavenumber. This somewhat less effective conjugation in **23**, compared to that in **11**, presumably arises because it entails formal disruption of the aromatic character of the carbocyclic aromatic ring, as well as that of the heterocyclic entity, whereas conjugation through the NH-C=C-C=O “vinylogous” substructure in **11** affects only the aromatic nature of the “pyrrole” ring.

As with the spectra of its isomers, **24** and **25**, the band in the FT-Raman spectrum of **23** at 3057 cm^{-1} may be assigned to one or more sp^2 C-H stretching vibration(s); the corresponding band in the FT-IR was too weak to be detected with confidence. At slightly lower wavenumber, the medium and weak bands at 2931 and 2861 cm^{-1} in the FT-IR spectrum of **23** may be

attributed to sp^3 C-H stretching vibrations, as may the bands of medium intensity in the FT-Raman at 2939 and 2901 cm^{-1} . The strong or medium bands in the FT-Raman spectrum of **23** at 1629, 1493, 1574 and 1374 were identified as C=C benzene ring quadrant stretch, C=C stretch of 5-membered ring of indole, N-H bend and C-N stretch respectively, see above Table (13) and Figure (10).

3.3.3. Infrared and Raman of *n*-cycloalkan[*b*]indoles Indoles

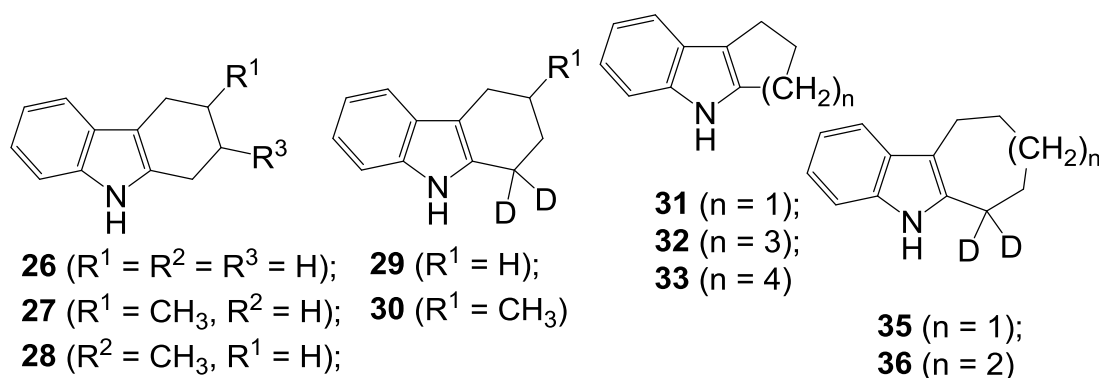

The major bands in the vibrational spectra of the tricyclic and tetracyclic indoles (**26–33** and **35–36**) without additional functionalization other than one or two alkyl substituents in the third ring are discussed below. A total of 14 indoles of this kind were investigated in this part of the investigation, including four deuterium labelled analogues, Tables (14)–(19).

N-H vibrations

The band corresponding to the N-H stretching vibration appears between 3500 and 3300 cm^{-1} at the extreme high wavenumber region of the usual range for lactams (cyclic amides, which bear a superficial resemblance to indoles).^{138, 139, 141-143} The assignment of this N-H band is complicated by the fact that O-H vibrations give rise to absorption in this wavenumber range, especially in IR spectra.¹¹ However, these two categories of bands can be

distinguished by their intensity and general appearance; bands associated with N-H stretching vibrations are usually sharper and weaker than those of the corresponding to O-H stretching vibrations.¹¹ The vibrational spectra of primary amines contain two bands corresponding to the asymmetric and symmetric N-H stretching vibrations of the triatomic NH₂ group. The occurrence of the “extra” band in the spectra of primary amines makes it easier to differentiate them from secondary amines which usually only show a single N-H band. In the present context, the observation of only one band around 3400 cm⁻¹ indicates that these tricyclic compounds, **26–33** and **35–36**, Table (14-17) contain an N-H, rather than an NH₂, functional group.

Table (13): Important bands in the Infrared spectra^a of **26–30**

Wavenumber(cm ⁻¹) and intensity ^b					Proposed Assignment ^c
26	27	28	29	30	
3397(s)	3390(s)	3386(s)	3396(s)	3393(s)	ν(N-H)
3050(w)	3051(w)	3053(w)	3051(w)	3049(w)	ν(C-H) sp ²
2926(s) 2847(m)	2953(m) 2924(m) 2901(m) 2879(m) 2866(m) 2828(m)	2949(m) 2920(m) 2865(m) 2831(m)	2927(s) 2849(m)	2922(s) 2848(m)	ν(C-H) sp ³
-	-	-	2184(vw) 2093(w)	2173(vw) 2096(w)	ν(C-D) sp ³
1619(w)	1620(w)	1621(w)	1618(w)	1616(w)	ν(C=C) benzene ring
1439(s)	1452(m)	1450(m)	1439(s)	1456(s)	ν(C=C) 5-membered ring of indole
1588(m)	1586(w)	1587(m)	1587 (m)	1581(m)	δ (N-H)
1466(m)	1467(m)	1466(m)	1467 (s) 1357 (m)	1464(m) 1425(m)	δ (CH ₂)
-	1365(m)	1371(m)	-	1352(m)	δ (CH ₃)
1233(m)	1233(m)	1234(m)	1226(m)	1228(s)	ν(C-N)

^a Spectra were recorded in the solid state. ^b Qualitative classification of the intensity as follows: w (weak), m (medium), s (strong), v (very), br (broad); ν (stretch), δ (deformation). ^c Some assignments are necessarily tentative, particularly in the low wavenumber region of the spectra.

The band in an IR spectrum associated with stretching the N-H bond of indoles is usually reported to be strong and sharp, appearing between 3500 and 3350 cm^{-1} .^{138, 140, 147} The strong sharp bands at 3397, 3390, 3386, 3394, 3387 and 3382 cm^{-1} observed in FT-IR spectra of **26**, **27**, **28**, **31**, **32** and **33**, respectively, were readily assigned to the indole N-H stretching vibration. Without the presence of the carbonyl group, which complicates the spectra of the ketoindoles, this band is of characteristic value in revealing that the heterocycles contain the indole substructure.

Table (15): Important bands in the Raman spectra^a of **26-29**

Wavenumber(cm^{-1}) and intensity ^b				Proposed Assignment ^c
26	27	28	29	
3401(w)	3397(w)	3384(w)	3401(w) ^d	$\nu(\text{N-H})$
3051(m)	3059(s)	3059(m)	3054 (s)	$\nu(\text{C-H}) \text{ sp}^2$
2932(s)	2953(m)	2949(m)	2938(s)	$\nu(\text{C-H}) \text{ sp}^3$
2883(m)	2924(s)	2920(s)	2883(m)	
2851(m)	2867(s)	2867(s)	2847(s)	
	2831(m)	2843(m)		
			2192(w)	$\nu(\text{C-D}) \text{ sp}^3$
			2142(w)	
			2126(w)	
			2089(w)	
1584(m)	1592(s)	1584(s)	1588(s)	$\nu(\text{C=C})$ benzene ring
1470(m)	1466(s)	1466(s)	1446(m)	$\nu(\text{C=C})$ 5-membered ring of indole
1564(m)	1572(s)	1564(s)	1568(m)	$\delta(\text{N-H})$
1474(m)	1470(m)	1474(m)	1474(m)	$\delta(\text{CH}_2)$
1437(w)	1429(m)	1421(m)	1368(w)	
-	1376(m)	1371(m)	-	$\delta(\text{CH}_3)$
1299(m)	1287(m)	1299(m)	1291(s)	$\nu(\text{C-N})$

^a Spectra were recorded in the solid state. ^b Qualitative classification of the intensity as follows: w (weak), m (medium), s (strong), v (very), br (broad); ν (stretch), δ (deformation). ^c Some assignments are necessarily tentative, particularly in the low wavenumber region of the spectra. ^d very weak band.

In addition, weak N-H stretching bands are found in the FT-Raman spectra at 3401, 3397, 3384, 3397, 3392 and 3389 cm^{-1} in **26**, **27**, **28**, **31**, **32** and **33**, respectively. The strongly polar nature of the N-H bond in indoles makes this N-H stretching vibration strongly active in the IR because it induces a large change in the dipole moment of the molecule. In contrast, this mode is only weakly active in the Raman, because the vibration causes relatively little change in the shape of the polarisability ellipsoid. These factors account for the difference in the intensity of the N-H stretching band in the two complementary types of vibrational spectra.

Similarly, the strong N-H stretching band at 3396, 3393, 3387 and 3384 cm^{-1} , respectively, in the FT-IR spectra of the deuterium labelled analogues, **29**, **30**, **35** and **36**, is also characteristic of the indole entity, Table (4). As with the unlabelled parent heterocycles, the corresponding bands in the FT-Raman spectra appear at similar wavenumbers, but are very much weaker. However, for compound **24**, this band was missing from the Raman spectrum, presumably because it was too weak to be identified. These differences between the IR and Raman spectra indicate that the former kind of vibrational spectroscopy is more useful in an analytical context for polycyclic indoles with little or no additional functionality.

C-H vibrations

Generally, as noted previously in section **3.3.2**, the bands arising from sp^2 C-H stretching vibrations in compounds containing an aromatic ring or an alkenyl group appear between about 3100 and 3000 cm^{-1} ; in contrast, the corresponding bands associated with sp^3 C-H stretching vibrations appear

just below 3000 cm^{-1} .^{138-141, 148, 149} These assignments reflect the degree of s-character in these bonds: a higher proportion of s-character results in a stronger bond, which has a greater vibrational quantum, thus increasing the wavenumber of the associated band in the vibrational spectrum. On this basis, the characteristic weak or medium bands in the region between 3059 and 3020 cm^{-1} in both the FT-IR and FT-Raman of the tricyclic indoles, **26-33** and **35-36**, were interpreted as sp^2 C-H stretches. On the other hand the rather larger number of bands between 2953 and 2802 cm^{-1} of varying intensity (from weak to quite strong in a few cases) were assigned to sp^3 C-H stretching vibrations. In the spectrum of **27**, the sp^3 region showed additional bands arising from the extra CH_3 (and CH) group(s) in this compound; the bands at 2953 and 2879 cm^{-1} were assigned to CH_3 C-H stretching vibrations (asymmetric and symmetric). The absorption bands at slightly lower wavenumber (2924 and 2828 cm^{-1}) were attributed to sp^3 C-H stretching vibrations of CH_2 groups. The single sp^3 C-H stretching vibration of the CH group was associated with the band at 2901 cm^{-1} . As expected, the spectrum of **29**, which contains sp^3 C-H bonds only in its CH_2 groups, shows two absorption bands at 2927 and 2849 cm^{-1} corresponding to the associated asymmetric and symmetric C-H stretching vibrations of these CH_2 groups.

As is the case with many functional groups, confirmatory information to support deductions made on the basis of assignment of bands associated with stretching vibrations can be made by detecting the corresponding bands associated with deformation modes. Unfortunately, these deformation bands tend to appear in the high wavenumber end of the fingerprint region (below about 1500 cm^{-1}). Since all these heterocycles contain one or more CH_2

group(s), the medium bands observed at approximately 1476 cm^{-1} in both the FT-IR and FT-Raman spectra can be assigned to CH_2 bending vibrations. A parallel methodology may be applied for the deformation bands for CH_3 groups in the spectra of **27**, **28** and **30**, each of which contains a methyl group. The medium intensity bands at 1365 , 1371 and 1352 cm^{-1} in the FT-IR spectra of **27**, **28** and **30**, respectively, were assigned to CH_3 bending vibrations, thus providing additional confirmatory information.

Table (16): Important bands in the FT-IR spectra^a of **31–33** and **35–36**

Wavenumber(cm^{-1}) and intensity ^b					Proposed Assignment ^c
31	32	33	35	36	
3394(vs)	3387(s)	3382(s)	3387(s)	3384(s)	$\nu(\text{N-H})$
3046(w)	3054(w) 3028(w)	3055(w)	3054(w)	3054(w)	$\nu(\text{C-H})\text{ sp}^2$
2931(m) 2849(m)	2911(s) 2844(m)	2918(s) 2846(s)	2911(s) 2843(m)	2920(s) 2847(s)	$\nu(\text{C-H})\text{ sp}^3$
-	-	-	2162(w) ^d	2162(w) ^d	$\nu(\text{C-D})\text{ sp}^3$
1617(w)	1618(w)	1619(w)	1616(m)	1616(w)	$\nu(\text{C=C})$ benzene ring
1444(s)	1425(s)	1438(s)	1433(m)	1437(s)	$\nu(\text{C=C})$ 5-membered ring of indole
1579(m)	1577(w)	1580(w)	1575(m)	1579(w)	$\delta(\text{N-H})$
1462(m)	1465(s) 1367(m)	1465(s) 1448(s)	1463(s)	1467(s)	$\delta(\text{CH}_2)$
1212(m)	1232(m)	1235(m)	1215(m)	1236(m)	$\nu(\text{C-N})$

^a Spectra were recorded in the solid state (ATIR). ^b Qualitative classification of the intensity as follows: w (weak), m (medium), s (strong), v (very), br (broad); ν (stretch), δ (deformation). ^c Some assignments are necessarily tentative, particularly in the low wavenumber region of the spectra. ^d very weak bands.

C-D vibrations

As a result of isotope effects, which reflect an increase in the reduced mass of the C-D bond compared to that of the C-H bond, the bands attributable to C-D stretching vibrations are usually in the region of 2300-2100 cm^{-1} . The ratio of the wavenumber of the C-H to the C-D band is usually approximately 1.35-1.38, corresponding to an isotopic shift of roughly 700 cm^{-1} .¹⁵⁰ In the spectra of compounds containing a $\text{C}\equiv\text{C}$, $\text{C}\equiv\text{N}$, $\text{C}=\text{C}=\text{C}$ or related functional group, which also vibrate at wavenumbers in a similar range to those for C-D stretching modes, the unequivocal identification of C-D bands may be complicated. However, none of the indoles under investigation contains a triple bond or a pair of cumulated double bonds, thus facilitating the unambiguous assignment of the C-D stretching bands. Furthermore, the absence of the characteristic strong and sharp band at approximately 3300 cm^{-1} associated with the sp C-H stretching vibration of terminal acetylenes in the spectra of **29-30** and **35-36** confirms that no $\text{C}\equiv\text{C}$ bonds of that kind are present in these heterocycles. In addition, the band at approximately 2200 cm^{-1} associated with the $\text{C}\equiv\text{C}$ stretching vibration is normally strong in Raman spectra because of the large change that it produces in the polarisability ellipsoid. Consequently, the absence of this band in the FT-Raman spectra is further evidence that the bands observed in this region are due to C-D stretching vibrations (rather than associated with $\text{C}\equiv\text{C}$ stretching modes). Accordingly, in both the FT-IR and FT-Raman spectra of **29-30** and **35-36**, the fairly weak absorption bands observed between 2200 and 2080 cm^{-1} may be assigned with confidence to sp^3 C-D stretches of CD_2 groups.

C=C vibrations

Bands that may be ascribed to C=C stretching vibrations are normally observed at wavenumbers between 1650 and 1450 cm^{-1} in both IR and Raman spectra.¹³⁹ This band is usually of medium intensity but is occasionally made stronger by the effect of conjugation, especially with C=O bonds in IR spectroscopy.

Table (17): Important bands in the FT-Raman spectra^a of **31-33**, **35-36**.

Wavenumber(cm^{-1}) and intensity ^b					Proposed Assignment ^c
31	32	33	35	36	
3397(w)	3392(w)	3389(w)	-	3384(w) ^d	$\nu(\text{N-H})$
3053(w)	3054(w)	3054(m)	3054(w)	3058 (w)	$\nu(\text{C-H}) \text{ sp}^2$
2936(s)	2928(s)	2932(s)	2920(w)	2919(s)	$\nu(\text{C-H}) \text{ sp}^3$
2887(m)	2900(m)	2912(s)	2904(w)	2905(s)	
2847(m)	2887(m)	2855(s)	2847(w)	2805(s)	
-	-	-	2122(w) ^d	2183(w) ^d 2150(w) ^d 2128(w) ^d 2095(w) ^d	$\nu(\text{C-D}) \text{ sp}^3$
1584(m)	1576(s)	1584(s)	1576(m)	1583(s)	$\nu(\text{C=C})$ benzene ring
1470(m)	1462(m)	1437(m)	1441(w)	1436(m)	$\nu(\text{C=C})$ 5-membered ring of indole
1564(m)	1560(s)	1568(s)	1560 (m)	1561(s)	δ (N-H)
1474(m)	1462(m)	1462(m)	1466 (m)	1467(m)	δ (CH_2)
1446(m)	1437(w)	1372(m)	1364 (w)	1363(w)	
1287(m)	1291(m)	1307(m)	1299(m)	1301(m)	$\nu(\text{C-N})$

^a Spectra were recorded in the solid state (ATIR). ^b Qualitative classification of the intensity as follows: w (weak), m (medium), s (strong), v (very), br (broad); ν (stretch), δ (deformation). ^c Some assignments are necessarily tentative, particularly in the low wavenumber region of the spectra. ^d very weak bands.

The C=C stretching bands are stronger in Raman than IR spectra owing to the polarisability of this bond, which does not usually possess the large electric dipole moment that is associated with bonds which give rise to strong bands in the IR when they vibrate. In both the FT-IR and FT-Raman spectra, the two bands at approximately 1600 and 1430 cm^{-1} are assigned to the stretching vibrations of C=C bonds. The former are logically ascribed to the C=C bonds of the benzenoid ring (technically an aromatic ring quadrant vibration); the latter may be associated with stretching of the C=C bond contained only in the heterocyclic ring. Thus, in the Raman spectra of **26**, **27**, **28**, **31**, **32** and **33**, the strong or medium band at 1584, 1592, 1584, 1584, 1576 and 1584 cm^{-1} may be assigned to stretching vibrations of the C=C bonds in the benzenoid ring.¹⁴³ All the corresponding bands in the IR spectra that may be associated with the C=C bonds of the carbocyclic ring were of either medium or weak intensity, occurring at 1619, 1620, 1621, 1617, 1618 and 1619 cm^{-1} in the spectrum of **26**, **27**, **28**, **31**, **32** and **33**, respectively.

The band associated with stretching the C=C bond in only the heterocyclic ring of the indole entity was seen at approximately 1450 cm^{-1} in both the Raman and IR spectra; the bands in the Raman spectra were usually stronger than their counterparts in the IR spectra. For instance, in the FT-IR and FT-Raman spectra of **30**, **35** and **36**, this vibration mode was assigned to the bands at 1439/1446, 1433/1441 and 1437/1436 cm^{-1} , respectively. Signals were present at similar wavenumber in the Raman spectra of the unlabelled species **26**, **27**, **28**, **31**, **32** and **33**. On the whole, Raman spectroscopy appears to offer a better means of detecting C=C bonds than IR spectroscopy in these heterocyclic systems.

3.4. Conclusion

In this chapter, the mass and vibrational spectra of a representative set of *n*-oxocycloalkan[*b*]indoles and *n*-cycloalkan[*b*]indoles have been discussed. For the *n*-cycloalkan[*b*]indoles, particular attention is focused on the use of infrared spectroscopy to determine whether *n*-oxocycloalkan[*b*]indoles may best be described as ketoindoles or hydroxyindolenines. When the carbonyl group is conjugated with the C=C of the pyrrole ring as in the case of when the carbonyl group is in the 4 position of the third ring, the bands in the solid state infrared spectra associated with stretching the N-H and C=O bonds appear at unusually low wavenumbers. Hence, these compounds were initially interpreted to be hydroxyindolenines rather than the more stable and common ketoindole tautomers, owing to the strong intermolecular hydrogen bonding between the N-H and C=O in the solid state; however, in solution, the fact that these compounds were ketoindoles was obvious. In contrast, isomeric 2- and 3-oxocyclohexan[*b*]indoles showed the typical N-H and C=O stretching vibrations even in solid state. These isomers are easily identified as ketoindoles even in the solid state. The 1-oxocyclohexan[*b*]indoles resemble their isomeric 4-oxocyclohexan[*b*]indoles more than the corresponding 2- and 3-oxocyclohexan[*b*]indoles because the C=O is also conjugated to the C=C of the pyrrole ring but the conjugation is less effective. Consequently, these compounds showed a C=O stretching band at low wavenumber and a normal N-H stretching vibration in their spectra.

Significant fragment ions that were present in the mass spectra of all the indoles allow valuable structural information to be obtained. The fragment

ions allowed the *n*-oxocyclohexan[*b*]indoles to be distinguished from each other. Additionally, ionised 6,5,6 tricycles lost an alkene while the homologous ionised indoles with a 6,5,7 or 6,5,8 ring pattern eliminated an alkyl radical. These fragment ions also help to differentiate tricyclic indoles with a 6,5,7 ring pattern from their 6,5,6 isomers containing an extra methyl group; similar remarks apply to distinguishing 6,5,8 tricyclic indoles from their 6,5,6 homologue(s) with two methyl groups in the third ring. Parallel trends are found for the corresponding *n*-cycloalkan[*b*]indoles: the ionised 6,5,6 tricycles fragment by loss of an alkene, whereas their analogues with a 6,5,7 and 6,5,8 ring pattern tend to eliminate one or more alkyl radical(s). Finally, the presence of one or two methyl group(s) in the appropriate position(s) in the third ring is revealed by loss of a larger alkene (C₃H₆ or C₄H₈), rather than C₂H₄, from the ionised tricyclic indole.

4.0. FORMATION OF COVALENTLY BOUND DIMERS FROM INDOLES IN THE POSITIVE ION ELECTROSPRAY MASS SPECTROMETRY

4.1. Background

The previous chapter describes how a combination of mass spectrometry and vibrational spectroscopy permits a range of tricyclic indoles to be detected. In addition, careful analysis of the spectroscopic properties of tricyclic model compounds allows the presence and position of a carbonyl group in the non-aromatic third ring to be established. The next step in evaluating the potential of these model heterocycles in a spectroscopic protocol for detecting scytonemin and related compounds is to determine how little substrate can be detected, both when pure samples are investigated and when other materials are present in a mixture. In determining these detection limits, mass spectrometry was used mainly because of its exceptional sensitivity. Certain ionisation methods, particularly electrospray (ESI),¹⁵¹ have clear advantages in producing ions from involatile analytes. In addition, electrospray is readily combined with chromatography, thus facilitating the analysis of mixtures. Consequently, liquid chromatography mass spectrometry (LC-MS) in combination with positive ion electrospray ionisation (ESI+) was chosen for this part of the investigation. The combination of LCMS and ESI+ appeared to be ideal because it circumvented the need to volatilise the analyte, which could instead be introduced into the mass spectrometer during the LC process. It was anticipated that the deuterium labelled analogues, which had already been

synthesised, would serve as internal calibrants for quantification of the analysis of model tricyclic heterocycles that had common structural features with scytonemin. The addition of a known quantity (a “spike”) of the requisite labelled analogue into a mixture containing an unknown quantity of the unlabelled tricyclic heterocycle was expected to allow the amount of the unlabelled compound to be determined by direct comparison of the intensities of the MH^+ signal (from the unlabelled material) and the corresponding $M'H^+$ signal (produced by protonation of the labelled analogue) two m/z units above the MH^+ signal.

The invention of new ionisation methods during the last four decades has revolutionised mass spectrometry, especially in biological, medicinal and environmental contexts. The development of ESI in combination with liquid chromatography has had a major impact in the analysis of biopolymers since this technique was first applied to ionise biologically important compounds of high molecular mass.¹⁵² Furthermore, advances in instrumentation, particularly the development of hybrid and multistage mass spectrometers, in which the dissociation of fragment ions can be routinely studied, permits the structure of fragment ions formed by several consecutive fragmentations of the precursor ions to be probed in great detail. These MS^n experiments, where n denotes the number of stages in the mass spectrometry investigation, can furnish all manner of useful information on the structure and reactivity of the ion under investigation. In favourable cases, n may be as large as five or six.

Not only is ESI a “soft” ionisation method (which tends to produce few fragment ions), thus allowing molecular mass information to be obtained, but

it also permits the study of interactions between proteins.^{153, 154} Recent studies have shown the formation of non-covalently bound “dimer” ions in ESI mass spectra¹⁵⁵⁻¹⁵⁸ For example, multiple hydrogen bonding over one or more proton bridge(s) has been reported to facilitate the formation of non-covalently bound “dimers”. These “dimers” have been found to undergo fragmentations up to the level of MS⁵.^{156, 159}

The production of $[2M+H]^+$ “dimers” and $[3M+H]^+$ “trimers” and even higher order “polymers” is relatively common in positive ion ESI (ESI+), especially if the concentration of analyte is relatively high. These species are generally agreed to be non-covalently bound (that is, the monomeric components are held together by binding to the proton by means of a combination of forces, including hydrogen bonding, but without the formation of a covalent bond between specific atoms in the components). The formation of covalently bound dimers (such as $[2M-H]^+$, in which a new covalent bond between the original monomeric units has been made, is far less commonly encountered). The production of these species corresponds formally to an “oxidative dimerisation”, which could be envisaged to occur by loss of molecular hydrogen (H_2) from the corresponding $[2M+H]^+$ non-covalently bound dimer.

The formation of covalently bound $[2M-H]^+$ species has been found to be amplified by the use of on-line electrochemical cells.¹⁶⁰ The application of voltage promotes the formation of these dimeric species either in an electrochemical cell or during the negative ion (ESI-) ionisation process; in addition, the production of these dimers is concentration dependent.

When work to determine the detection limits for LCMS analysis of tricyclic indoles was initiated, it was found that the analyte (the unlabelled model compound) and the internal calibrant (the labelled analogue) reacted to form a heterodimer $[M+M'-H]^+$. Although this unexpected complication made quantification by this approach very difficult, if not impossible, it led to an interesting investigation of the mechanism of this process and valuable conclusions about the analytical and synthetic utility of the reactions that can occur under ESI+ conditions. These experiments are summarised in this chapter.

4.2. Experimental

LC-MS analysis was carried out on a hybrid Linear Ion-Trap-OrbiTrap mass spectrometer system (Thermo Scientific LTQ OrbiTrap XL) fitted with a Ultra High Performance Liquid Chromatography (UHPLC) system consisting of a binary pump, an autosampler and a photodiode array detector (Acquity: Binary Solvent Manager, Sample Manager and PDA Detector respectively, Waters Ltd., Elstree, UK). The chromatography system and mass spectrometer were controlled by the software Xcalibur v1.4 (Thermo Scientific Ltd., Hemel Hempstead, UK). The LC column was a Waters Acquity UPLC BEH C18, 1.7 μm , 2.1 mm x 100 mm. The sample was dissolved in methanol at $\sim 0.01 \text{ mg mL}^{-1}$ concentration and 10 μL was injected. The mobile phase flow rate was 0.45 mL min^{-1} . Mobile phase A was 0.05% aq. formic acid; mobile phase B was acetonitrile. The UHPLC gradient was T = 0.0, A = 95%, B = 5%, T = 9.0, A = 20%, B = 80%, T = 9.01, A = 2%, B = 98%, T = 11.0, A = 2%, B = 98%. At T = 11.01 min the system reverted to the starting conditions and was held for 4 mins to allow the column to re-

equilibrate. The PDA was scanned from 210 to 350 nm at 2 nm steps during the run. ESI+ was performed with a capillary voltage of 3 kV, a sheath gas flow of 50 and an auxiliary flow of 20 (arbitrary units) at a source capillary temperature of 250 °C. The mass spectrometer collected data every ~0.25 secs alternatively recording a mass spectrum over the mass range 100 to 800 amu and a product ion mass spectrum from the most intense ion detected in the mass spectrum. The resolution was 7.5 k (full width at half maximum) for both scan modes; the collision energy was 35 eV in the product ion experiments.

4.3. Results and Discussion

This section focused on attempts to use tricyclic indole, **32**, with a “6,5,7” ring pattern, as a model compound for syctonemin and related species. Exactly parallel effects were observed when the analogous “6,5,6” and “6,5,8” tricycles were studied. As outlined above, the detection limit was probed by using labelled internal calibrant as a means of quantifying the proportion of **14** in admixture with other compounds in methanol solution. These attempts to establish the detection threshold were hampered by the appearance of unexpected peaks at higher m/z (m/z 369, 371 and 373) corresponding to the formation of covalently bound dimer ions. The peak at m/z 369 was considered to arise from the interaction of two unlabelled analyte molecules (M) to form ions of general formula $[M+M-H]^+$. Similarly, the interaction of two labelled analytes (M') results in ion at m/z 373. Finally the signal at m/z 371 corresponds to a “heterodimer” $[M+M'-H]^+$ formed by interaction of the labelled standard (M') and the unlabelled analyte (M), Figure (11). In addition,

the expected $[M+H]^+$ and $[M'+H]^+$ signals were observed at m/z 186 and 188 corresponding to protonated unlabelled and labelled monomers, respectively.

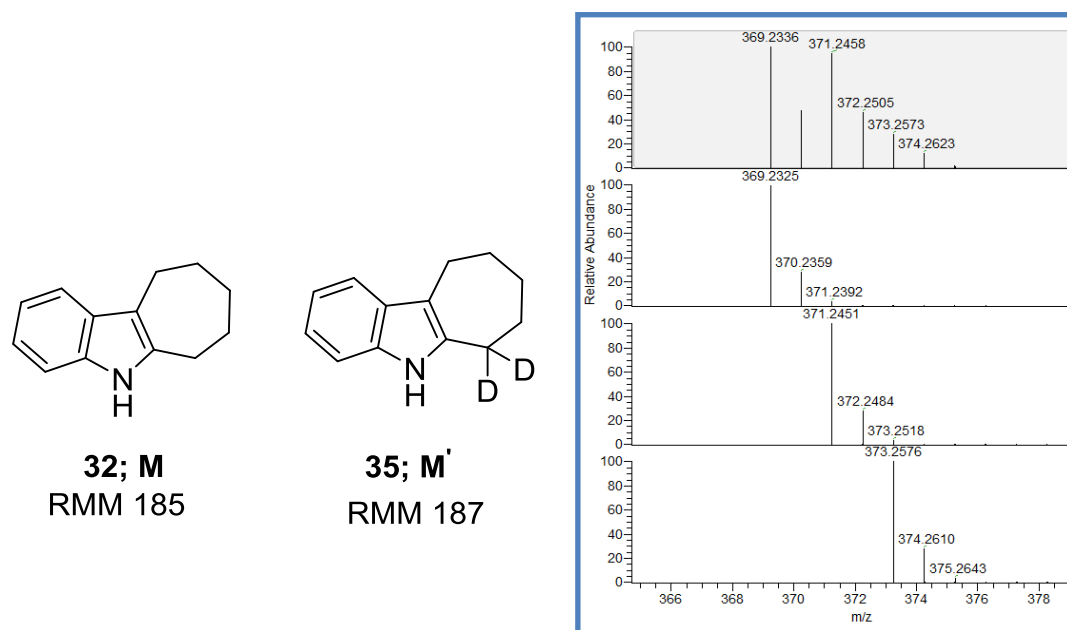

Figure (11): top: $[2M-H]^+$, $[M+M'-H]^+$ and $[2M'-H]^+$ experimentally observed signals in the ESI+ ion mass spectrum of an approximately equimolar mixture of **32** and **35**; below: theoretical isotope distributions for $[2M-H]^+$, $[M+M'-H]^+$ and $[2M'-H]^+$.

The elemental composition of these $[2M-H]^+$ ions was confirmed by accurate mass MS^n experiments at high resolution. The high resolution mass spectrum of the mixture showed that the experimentally measured values and the proposed theoretical values were within approximately ± 1 mDa, Table (18). These data establish unequivocally that the formulae of the ions correspond to those expected for $[2M-H]^+$, $[M+M'-H]^+$ and $[2M'-H]^+$.

Table (18): Difference in experimental and theoretical m/z values for the $[2M-H]^+$ species derived from tricyclic indoles **32** and **35**

Ion	Formula	Experimental value	Theoretical value	Error (mDa)
$[2M-H]^+$	$C_{26}H_{29}N_2$	369.2336	369.2325	1.055
$[M+M'+H]^+$	$C_{26}H_{27}D_2N_2$	371.2458	371.2451	0.681
$[2M'-H]^+$	$C_{26}H_{25}D_4N_2$	373.2572	373.2576	-0.312

4.3.1. Structure of the Dimeric Species

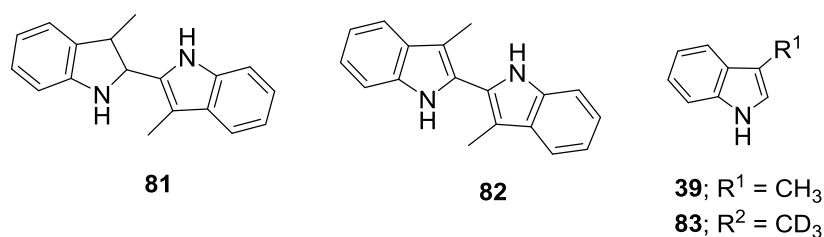

Further attempts to elucidate the structure of dimeric $[2M-H]^+$ species were made by investigating simpler indoles without a third fused ring but with one or two alkyl substituents instead. In particular, 3-methylindole, **39**, and its trideutromethyl analogue, **83**, were analysed; 3-methylindole was chosen because the relevant dimeric species (**81** and **82**) formed by dimerisation in solution are well known from earlier work. This information allowed the behaviour of $[2M-H]^+$ formed from **39** to be compared those of $[M+H]^+$ ions formed from **81** and **82**. Authentic samples of dimeric compounds, **81** and **82**, were synthesised from 3-methylindole, **39**, Scheme (33).

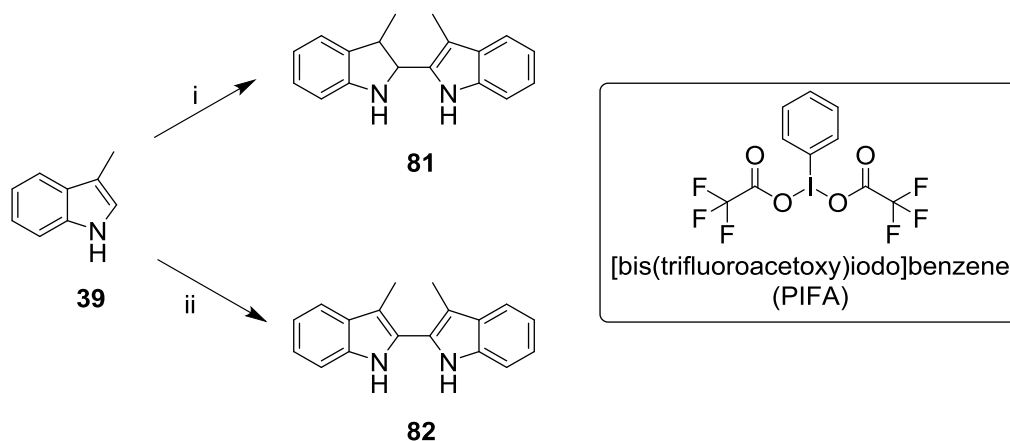

Scheme (33) Reagent and conditions: i) TFA, RT, 3 hr; ii) PIFA/TMSBr, DCM, -78 °C – 40 °C, 3hr, 50%.

When the separate ESI⁺ spectra of 3-methylindole, **39** [M], and 3-(methyl-d₃)indole, **83** [M'], were obtained, the base peak in each spectrum corresponded to the $[2M-H]^+$ and $[2M'-H]^+$ ion, respectively, derived from

each individual analyte. Furthermore, when a solution of an approximately equimolar mixture of **39** and **83** was analysed under the same conditions, $[2M-H]^+$, $[M+M'-H]^+$ and $[2M'-H]^+$ signals were observed at m/z 261, 264 and 267, respectively, Figure (12).

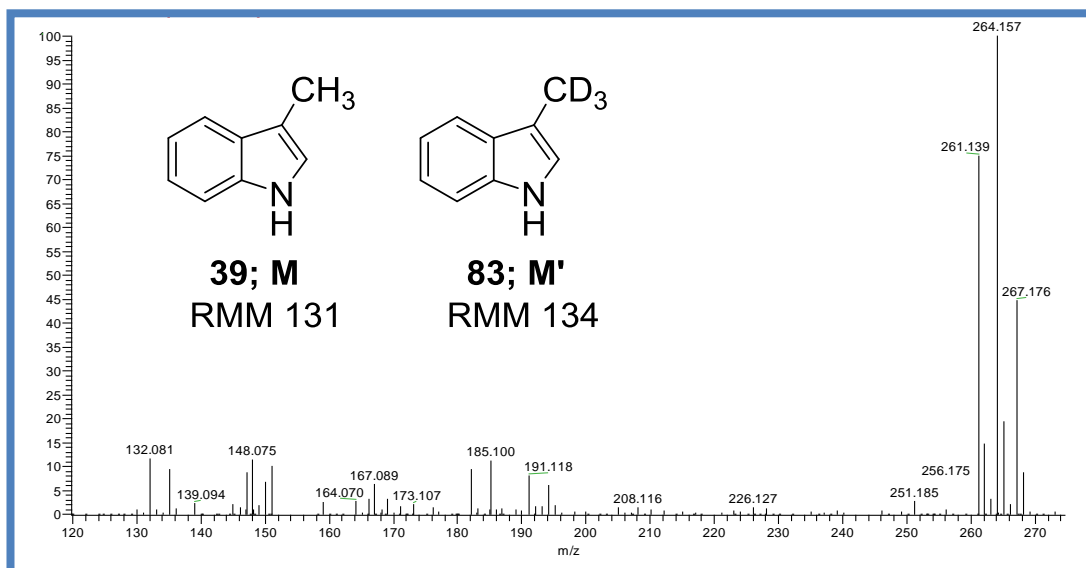
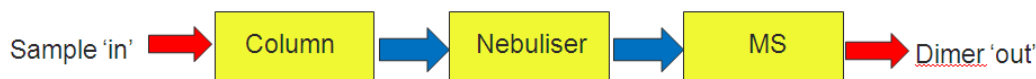

Figure (12): ESI+ mass spectrum of a mixture of **39** and **83**.

These results indicate that the formation of the covalently bound dimer, which was first detected for tricyclic indoles, also occurs for 3-methylindole; moreover, as is the case with the tricyclic species, homodimers and heterodimers are formed when a mixture of labelled and unlabelled analytes is subjected to ESI+.

4.3.1.1. Where is the Dimer Forming?

The formation of the $[2M-H]^+$ species could occur in three different places in the LCMS instrument used in this work: firstly, in the LC column; secondly in the nebuliser (spray droplets); and, thirdly, in the mass spectrometer itself.



Nebuliser Synthesis

The possibility of the dimers forming in the nebuliser was investigated by taking the nebuliser “offline” from the instrument housing. A methanol solution of the **39** was infused into the nebuliser over 30 seconds. The resultant spray was collected in a conical flask and injected back into the online instrument (see illustration in Figure (13)).

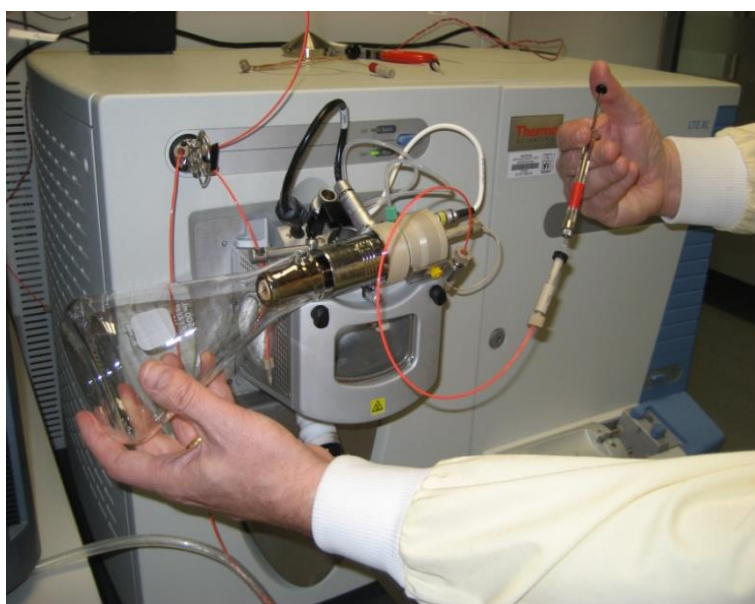
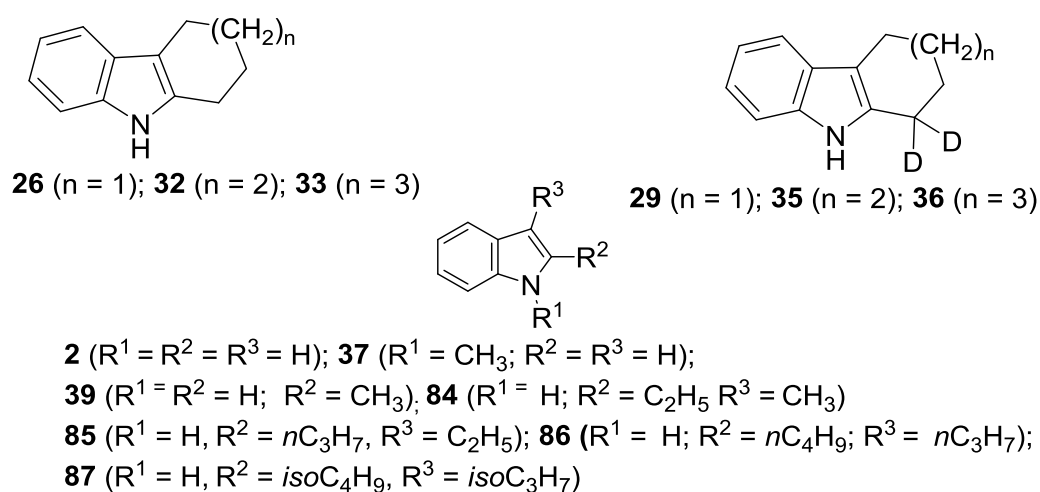

Figure (13): Spraying of the sample through the nebuliser.

When the mass spectrum of the effluent collected was obtained, two peaks with different retention times were detected in the LC part of the instrument. The first component had the same retention time as 3-methylindole, **39**; it gave a spectrum that showed signals corresponding to $[MH]^+$ formed from **39** and the expected $[2M-H]^+$ dimer. The second component had the same retention time as authentic **82**; it produced a mass

spectrum that showed only ions corresponding to $[2M-H]^+$ formed from **39**. This experiment shows that dimerisation occurs in the nebuliser section of the LC/ESI system. Furthermore, this result is evidence that a covalently bound species is responsible for the $[2M-H]^+$ signal. A non-covalently bound adduct would not be expected to survive passage through the LC system.

4.3.2. Scope of the Reaction



To probe how general the formation of these $[2M-H]^+$ dimers is, a wide range of other indoles, including tricyclic species with “6,5,6” and “6,5,8” ring patterns, were investigated under the same conditions. The results revealed that the novel $[2M-H]^+$ signals that appeared in the ESI+ spectrum of **32**, are also seen in **26** (m/z 341) and **33** (m/z 397), Table (19). As indicated in the introductory part of this chapter, when the dideuterated analogues of **26** and **33** were analysed, signals appeared at 2 and 4 m/z units above that observed in the spectrum of the requisite unlabelled parent compound.

Parallel trends were found in the ESI+ spectrum of an approximately equimolar mixture of **26** [M] and **29** [M']. The spectrum was dominated by signals corresponding to $[2M-H]^+$, $[M+M'-H]^+$ and $[2M'-H]^+$ at m/z 341, 343 and 345, respectively). Furthermore, exactly analogous results were obtained when an approximately equimolar amount of **33** [M] and **36** [M'] was analysed: the two expected $[M+H]^+$ and $[M'+H]^+$ signals were observed at m/z 200 and 202, respectively, together with three dimer peaks at m/z 397, 399 and 401, corresponding to $[2M-H]^+$, $[M+M'-H]^+$ and $[2M'-H]^+$, respectively.

Table (19): Important signals in ESI+ spectra of tricyclic and substituted indoles

Compound	Signals and Relative Intensity (RI) ^a		
	$[M+H]^+$	$[2M+H]^+$	$[2M-H]^+$
2	100	> 2	-
26	100	3	47
32	96	4	100
33	100	< 0.01	9
37	9	100	> 4
38	100	-	-
39	100	-	10
84	100	-	31
85	100	> 4	61
86	60	9	100
87	55	6	100

^a RI = Relative intensity, measured by peak height and normalised to a value of 100 for the most intense signal.

Dimers with the general formula $[2M-H]^+$ were also observed in the ESI+ spectra of a range of 3-alkyl and 2,3-dialkylindoles, including 2-ethyl-3-methylindole, **84**, 3-ethyl-2-propylindole, **85**, 2-butyl-3-propylindole, **86**, and 2-isobutyl-3-isopropylindole, **87**. All these spectra contained peaks corresponding to $[2M-H]^+$. Thus, the ESI+ spectrum of **85** showed peaks at

m/z 188 and 373, corresponding to $[M+H]^+$ and $[2M-H]^+$, respectively, Table (19). In addition, when an approximately equimolar solution of 6,5,8", **33** [M], **39** [M'], was analysed, the ESI+ spectrum showed only one peak at m/z 329 (RI 100) corresponding to the "cross" or heterodimer, Figure (14).

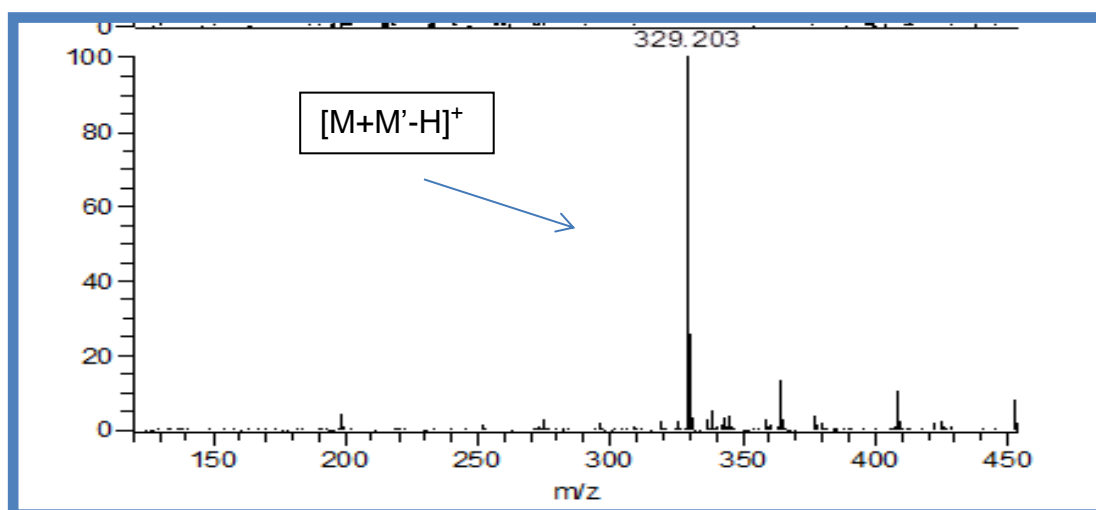
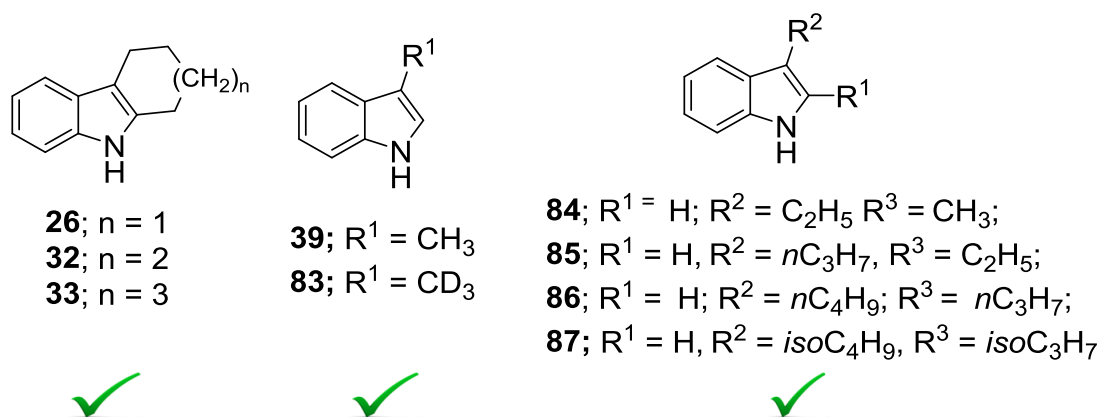

Figure (14): ESI+ mass spectrum of a mixture of **33** and **39**.

The novel $[2M-H]^+$ species are either not formed at all or else are produced in very low abundance from indoles with a substituent only in the 1 and/or 2 position. Thus, indole itself, **2**, 1-methylindole, **37**, and 2-methylindole, **38**, do not show significant signals corresponding to $[2M-H]^+$, Figure (15). This trends reveals that the production of the $[2M-H]^+$ ions is

preferentially associated with indoles that have an alkyl substituent (or its equivalent) in the 3 position.

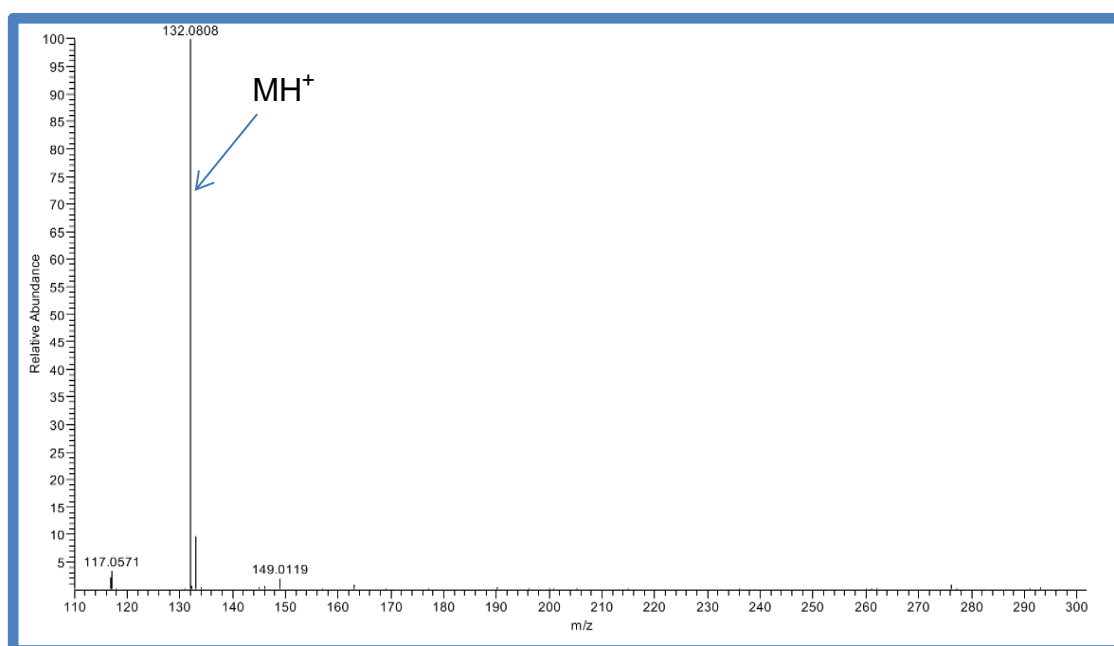
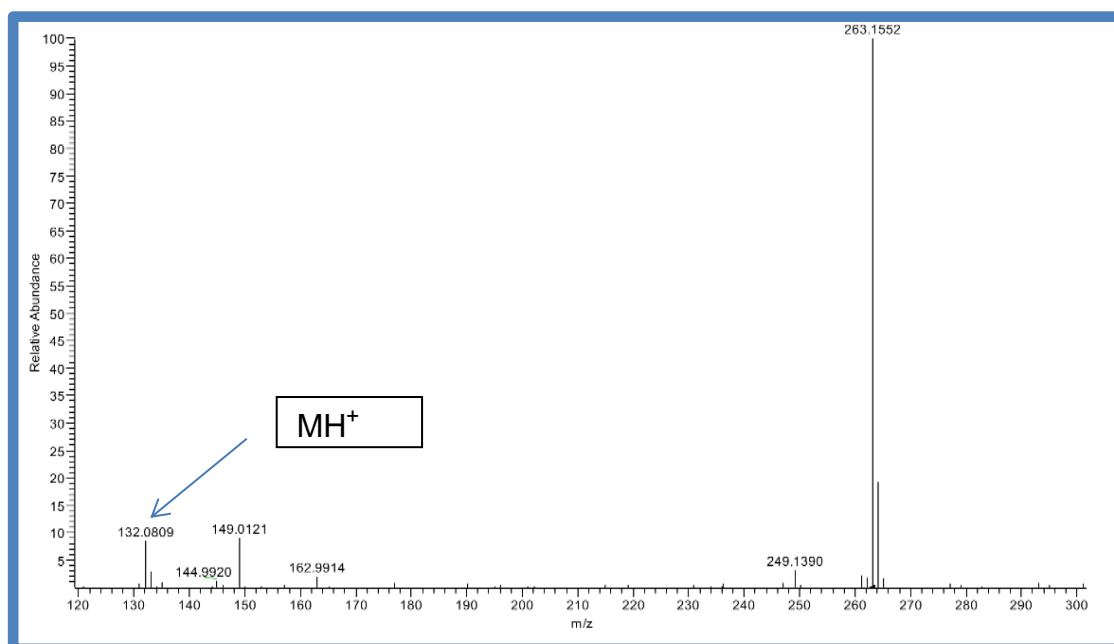
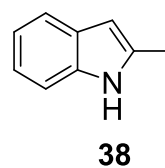
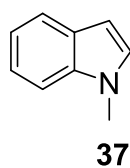
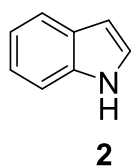

Figure (15): Positive ion electrospray ionisation mass spectra; top 1-methylindole, **37**; bottom 2-methylindole, **39**.

4.3.3. Origin of $[2M-H]^+$ Signal

As noted in the introductory part of this Chapter, $[2M+H]^+$ signals are often observed in ESI+ spectra, especially when the concentration of the analyte is high; in contrast, the appearance of $[2M-H]^+$ signals is much rarer. These $[2M+H]^+$ dimeric species are examples of proton bound dimers (PBDs) which have been studied over many years and well documented in gas phase ion chemistry.¹⁶¹⁻¹⁶⁴ It is possible, if not likely, that the two components of the PBD may react together, with one (the protonated monomer) behaving as an electrophile and the other (the unprotonated monomer) acting as a nucleophile. Such “recombination” processes also feature in the reactions of another well-known general class of “unconventional” ion structures, ion neutral complexes (INCs) in which ionic and neutral partners are held together by non-covalent forces.¹⁶⁵⁻¹⁶⁸ In contrast, the novel $[2M-H]^+$ ions observed in this work formally correspond to dehydrogenation of $[2M+H]^+$, by an overall process that could be broadly described as an oxidative dimerisation of M in the presence of a proton. The resultant $[2M-H]^+$ ion, which presumably contains a new bond between the two original monomers, must be a covalently bound “dimer”. Support for this interpretation is provided by more sophisticated gas-phase experiments in which the $[2M-H]^+$ ions are made to dissociate by being energised by collision.

These collision-induced dissociation¹⁶⁹ mass spectra of the $[2M-H]^+$ and $[M+M'-H]^+$ ions formed from the tricyclic indoles, **26**, **32** and **33** all contain signals that may be attributed to elimination of a small neutral species (especially $C_{n+1}H_{2n+2}$ and $C_{n+1}H_{2n}D_2$) from the third ring to form ions at higher m/z than $[M+H]^+$ or $[M'+H]^+$. It is highly unlikely that non-covalently

bound $[2M-H]^+$ or $[M+M'-H]^+$ species, in which the two components were held together only by relatively weak forces, would fragment in this manner, instead of simply separating to form $[M-H]^+$ and M (or M') and/or $[M+H]^+$ and $[M-H_2]^+$ (or $[M'-H_2]^+$).

Recent related studies have shown certain well-documented reactions can take place at an enhanced rate in the nebuliser section of the ESI+ instrument. For instance, Knoevenagel-type condensation has been reported to occur in the nebuliser by infusing an acidic solution of two reactants.¹⁷⁰ This discovery indicates that the formation of covalent bonds in the nebuliser of a mass spectrometer can occur, sometimes under far milder conditions than are required in conventional solution chemistry, thus providing circumstantial support for the proposal that the $[2M-H]^+$ ions formed from indoles are covalently bound. This possibility, which clearly has synthetic potential, will be emphasised later in this Chapter.

4.3.4. Mechanism of Formation of the Dimer

4.3.4.1. Oxidative Dimerisation

Further support for the interpretation that these $[2M-H]^+$ species are covalently bound dimers may be obtained by considering the known mechanisms for dimerisation of indoles in solution.

Under strongly acidic conditions in solution (typically treatment with neat trifluoroacetic acid, TFA), 3-methylindole (which has the trivial name “skatole”), **39**, is protonated at the 3 position^{171, 172} to give an electrophilic immonium ion, **88**, Scheme (34). Another molecule of skatole acts as a nucleophile and attacks **88** resulting in a $[2M+H]^+$ species, **89**. Re-

aromatisation of the ring by loss of a proton from the 2-position gives diskatole, **81**. This dimeric species consists of an indole and an indoline entity, which are linked by a new covalent bond connecting the carbons in the 2-position of each original monomeric unit. The key protonation step leads to the formation of a reactive secondary cation, which no longer possesses an aromatic heterocyclic ring. Consequently, nucleophilic attack by another molecule of **39**, in which the 2-position is not occupied by a methyl substituent, which might hinder the reaction, would be expected to be relatively straightforward. In contrast, the analogous protonation of 2-methylindole, **38**, would give rise to a more stable tertiary cation, which would be less reactive, thus slowing the nucleophilic attack by a second molecule of **38**, particularly since the methyl group in the 2-position of this nucleophile carries a methyl substituent, thus imposing further steric hindrance to the “dimerisation”. Although this contrast might explain why **38** does not show an $[2M+H]^+$ or $[2M-H]^+$ signal in its ESI+ spectrum, perhaps because the resulting immonium ion is too substituted to be reactive, it cannot explain the oxidation (or dehydrogenation) that would be required to convert **81** to **82**.

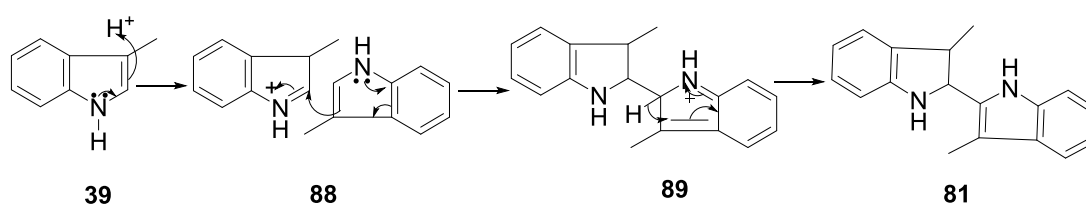

Scheme (34): Proposed mechanism for the formation of diskatole via oxidative dimerization.

Conclusive evidence that the $[2M-H]^+$ ions are not formed by dehydrogenation of the relevant $[2M+H]^+$ species under ESI+ conditions was

obtained by comparing the spectrum of authentic diskatole, **81**, with $[2M-H]^+$ ion formed from **39**. The ESI+ spectrum of the authentic **39** shows a strong $[M+H]^+$ signal (corresponding to $[2M+H]^+$ formed from **39**), but no $[2M-H]^+$ signal (corresponding to $[2M-H]^+$ generated from **39**). Therefore, the $[2M-H]^+$ ions are not formed from **39** by acid catalysed dimerisation, followed by elimination of H_2 , because the relevant $[2M+H]^+$ ions obtained by direct protonation of **81**, do not eliminate H_2 under the same conditions as those required to generate $[2M-H]^+$ from **39**. Furthermore, the formation of $[2M-H]^+$ ions from **39** in the spray produced in the nebuliser of mass spectrometer occurred under neutral pH conditions, without the introduction of a Bronsted acid (such as the highly acidic TFA) to catalyse the dimerisation that occurs in solution.

4.3.4.2. Electrochemical Process

The instrumentation for ESI+ includes a nebuliser, through which the solution of analyte is transmitted to produce an aerosol, usually with an electric voltage applied to the nozzle. Consequently, the effect of electrical potential running across the nebuliser on the dimerisation was investigated. Although the formation of the $[2M-H]^+$ ions occurred when a voltage was applied, the ratio of $[2M-H]^+$ to $[M+H]^+$ ions actually increased when the nozzle was earthed, Figure (16). This unexpected finding suggests that dimerisation of certain indoles may be induced without the application of a voltage. Therefore, the mechanism does not involve an electrochemical process.

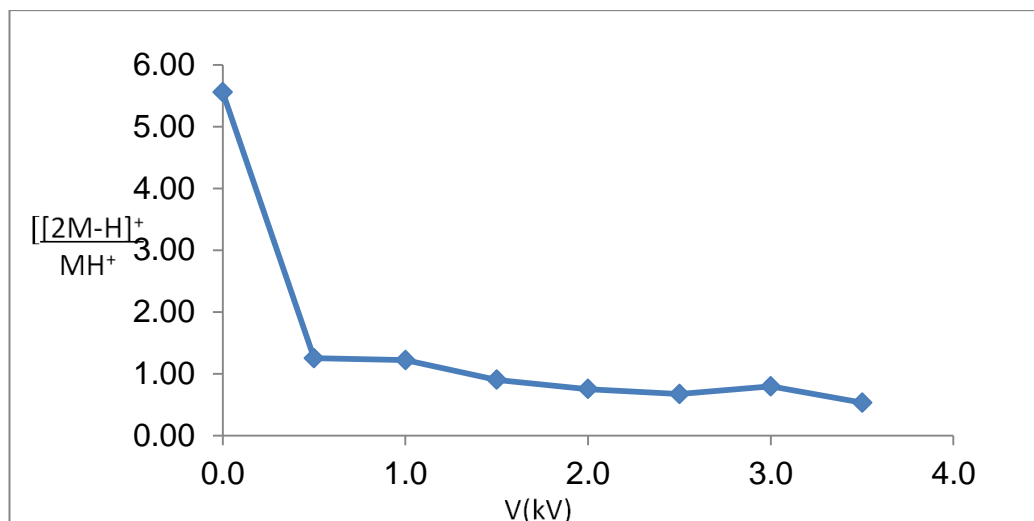
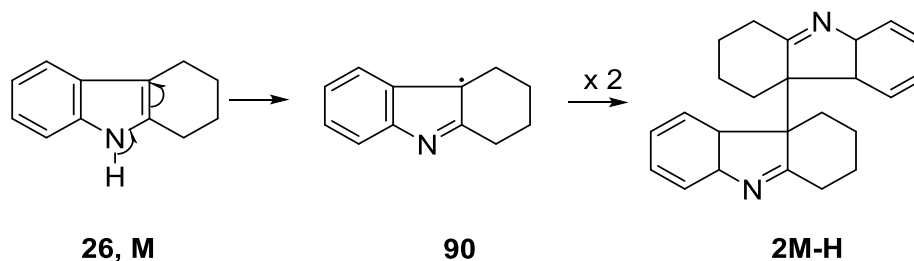

Figure (16): Variation in the relative abundance of $[2M-H]^+$ to $[M+H]^+$ with nebuliser voltage, V.

4.3.4.3. Radical Mediated Mechanism

After ruling out both an acid catalysed and an electrochemically induced mechanism for the dimerisation, the most likely alternative mechanism by which the $[2M-H]^+$ species are formed from **39** is by a radical initiated process. This mechanism proceeds via an indolyl radical, **90**, which may either couple with a second radical or react with a molecule of the parent indole to give an intermediate that may lose a hydrogen atom to restore the aromatic ring. Thus, coupling of the radical derived from **39** may give species corresponding to $[2M-H_2]$, as illustrated in Scheme (35).¹⁷³ This radical mechanism begins with loss of the hydrogen atom attached to nitrogen; consequently, it cannot occur for **37**, which has no N-H. Furthermore, the formation of the intermediate is unfavourable for **38** because the radical has only a secondary structure. In contrast, more stable tertiary radicals are formed by loss of the N-H from indoles with a 3-substituent, which do form

[2M-H₂] dimers by this radical mechanism, thus explaining the formation of [2M-H]⁺ (relative to the monomeric indole, which corresponds to [2M-H₂+H]⁺, relative to the species derived by this radical dimerisation process) ions under ESI⁺ conditions.



Scheme (35): Proposed radical mechanism.

The ESI⁺ spectra of the labelled indoles, **29**, **35** and **36** contain [2M-H]⁺ signals (corresponding to the protonated “dehydrodimer” ion) in which all four deuteria are retained. This finding is consistent with the radical mechanism illustrated in Scheme (35). A mechanism involving coupling of two indole species via the 2 or 4 positions of **39** or its labelled analogues, followed by elimination of molecular hydrogen, would lead in some cases to a protonated “dehydrodimer” ion in which one or more deuterium atom(s) had been lost.

The ESI⁺ spectrum of “dehydrodiskatole”, **81**, prepared independently by a radical coupling process, showed a strong [M+H]⁺ signal at m/z 261. Moreover, the CID spectrum of this ion was essentially identical to that of the [2M-H]⁺ ion obtained when **39** was subjected to ESI⁺ conditions. This result is further evidence that the [2M-H]⁺ species (relative to **39**) arise by a coupling process of a radical derived by loss of the N-H in 3-substituted indoles. Although **39** could undergo acid-catalysed dimerisation (which would

result in the appearance of the corresponding $[2M+H]^+$ signal, rather than the associated $[2M-H]^+$ peak, in its ESI+ spectrum), the radical mechanism (which leads to the production of a $[2M-H]^+$ signal, as is observed) takes place instead.

The 2-deuterioanalogue of **39** was prepared and analysed in the hope that it might show a $[2M+H-D_2]^+$ signal formed by loss of D_2 to determine the position of the dimerisation, Scheme (36). The spectrum showed the expected protonated monomer signal at m/z 133 as the base peak. However, only the 'normal' $[2M-H]^+$ signal was detected; no significant peak corresponding to the $[2M+H-D_2]^+$ ion was detected, Figure (17). One explanation for this observation is that isotope effects slow the rate of cleavage of the C-D bond(s), perhaps leading to coupling at another site.

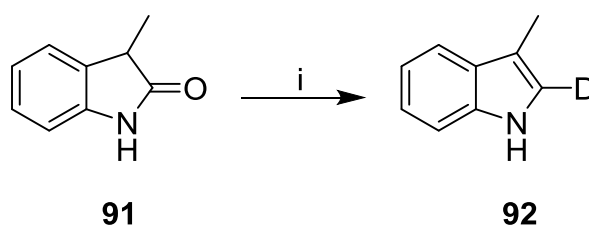

Scheme (36) *Reagents and condition:* i) $LiAlD_4$, THF, 30 hr, 57%.

The coupling of the tricyclic indoles (**26-33** and **35-36**) and 2,3-disubstituted indoles (**84-87**) must occur by a different mechanism because these heterocycles do not have a hydrogen atom at the '2-position' that can be lost during the "oxidative dimerization". In the hope of probing the mechanism by which these tricyclic indoles form $[2M-H]^+$ ions, a selection of tetrahydrocarbazole derivatives of **39** with a halogen atom (F, Cl or Br) or a methyl or methoxy group (CH_3 or CH_3O , respectively) in the carbocyclic aromatic ring were prepared and subjected to ESI+ mass spectrometry.

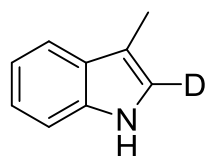

92

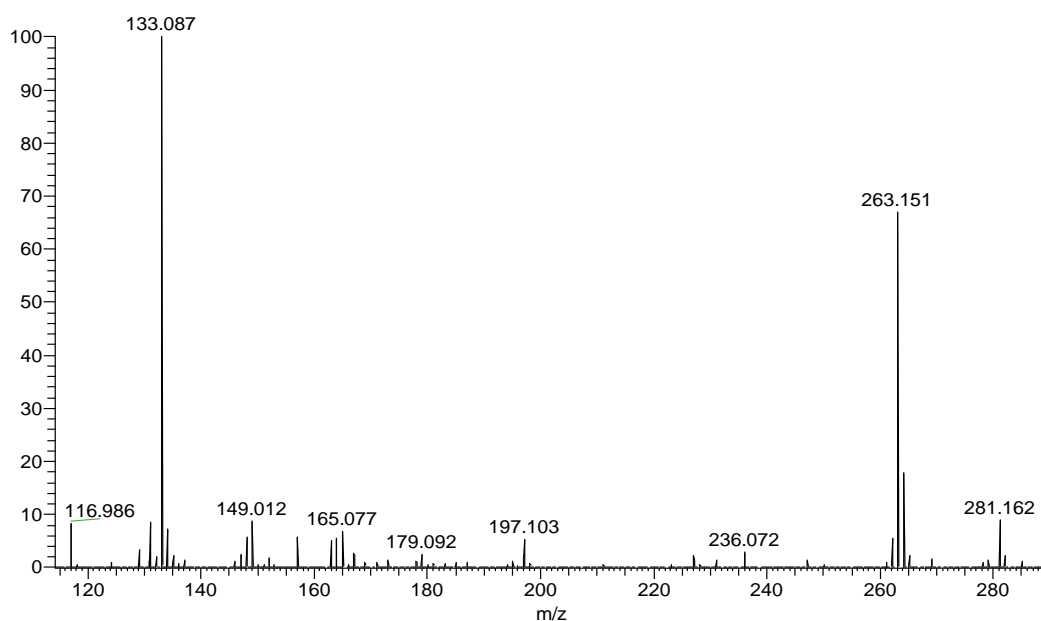
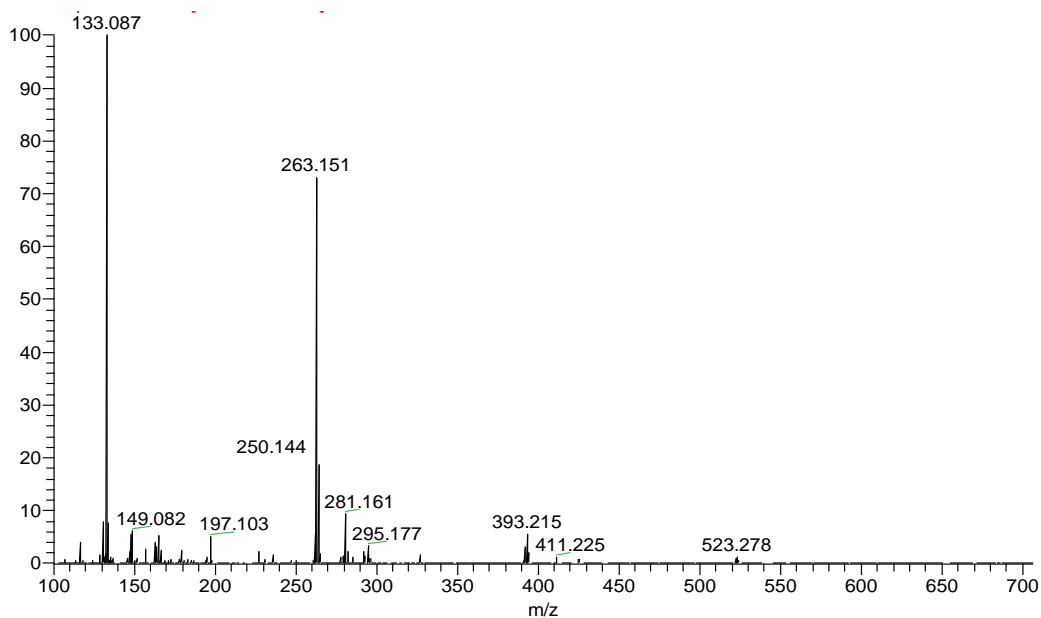

Figure (17): a) ESI+ spectrum of 2-deutero-3-methylindole, **92**; b) expanded spectrum to show the isotope pattern.

Unfortunately, however, none of these derivatives showed appreciable $[2M+H-X_2]^+$ or $[2M+H-HX]^+$ signals, but most formed significant $[2M-H]^+$ ions. Nevertheless, the relative abundance of the $[2M-H]^+$ ions varied with the

nature of the halogen atom and its position in the ring. These results appear to indicate that the coupling of the tetrahydrocarbazoles is subject to both steric and electronic effects, which are themes for further investigation. Unfortunately, the preparation of the corresponding skatoles with a halogeno, methyl or methoxysubstituent is far more challenging than the synthesis of the substituted tetrahydrocarbazoles. Ultimately, however, the behaviour of these substituted skatoles under ESI+ conditions may provide valuable further information on the site of the dimerisation, which currently cannot be unequivocally defined. It seems possible, if not likely, from the behaviour of the dideuterioanalogue of **80** that more than one site may be involved in the covalent bonding that leads ultimately to the production of $[2M-H]^+$ ions under ESI+ conditions. Moreover, the site at which the bonding occurs appears to be influenced by isotope effects (which would discriminate against any process in which cleavage of a C-D bond was the rate-limiting step) and steric and electronic factors. Further work is required to delineate these points with greater precision.

4.4. Conclusion

Although the site(s) at which the coupling that leads to the formation of $[2M-H]^+$ dimers from indoles has not so far been established in each case, the novelty of the overall process remains clear. Furthermore, it is highly likely that the formation of these dimers involves a radical-initiated or mediated pathway. It does not entail either an acid-catalysed or an electrochemically induced process. In addition, the analytical value of the $[2M-H]^+$ signals offers a means of distinguishing at a high level of sensitivity

indoles with a substituent in the 3-position from their isomers with the same substituent in the 1- or 2-position.

5.0. ACCELERATED FORMATION OF C=N IN POSITIVE ION ELECTROSPRAY SPECTROMETRY

5.1. Background

As noted in the previous chapter, very recent work has established that important organic reactions may be replicated and accelerated in ESI+ mass spectrometry.¹⁷⁰ This novel possibility, which occurs under comparatively mild conditions (approximately neutral pH and low temperatures) in a nebuliser, even without applying a voltage to the nozzle, has obvious synthetic potential.

In view of the ease with which certain indoles may be made to undergo coupling reactions to form $[2M-H]^+$ ions under ESI+, compared to the harsh conditions needed to effect similar processes in conventional solution methodology, the possibility of forming other covalent bonds under ESI+ conditions was explored. Since the formation of C=N bonds (as in imines and many nitrogen heterocycles) is very important in synthetic organic chemistry, systems of this general type were chosen for investigation.

5.2. Experimental

Essentially the same experimental procedure was adopted as for the analysis of the indoles summarised in the previous Chapter, Section 4.2.

5.3. Results and Discussion

5.3.1. Formation of Imines under Positive ESI Conditions

When the ESI+ spectrum of a mixture of an aryl aldehyde, ArCHO, with a slight excess of an arylamine, Ar'NH₂, was recorded, the anticipated

signals corresponding to the protonated amine were formed, together with almost equally strong signals for the protonated imine, $\text{ArCH}=\text{NAr}'$, but no signals for the protonated aldehyde or the tetrahedral adduct, $\text{ArCH}(\text{OH})\text{NHAr}'$, were detected. For example, when the ESI+ spectrum of a mixture of benzaldehyde, **93**, and 2-bromoaniline, **94**, was obtained, the spectrum showed pairs of peaks of nearly equal intensities at m/z 172 and 174 ($[\text{MH}]^+$ and its ^{81}Br isotope satellite formed by protonation of **94**) and m/z 260 and 262 (corresponding to $[\text{MH}]^+$ formed by protonation of 2-(bromophenyl)-1-phenylmethanimine **95**), Scheme (37) and Figure (18).

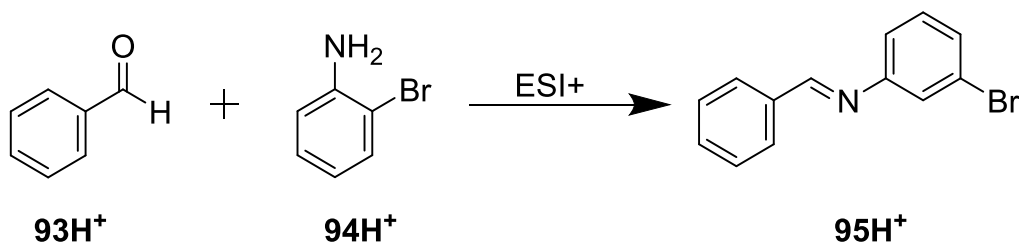

Scheme (37): Formation of imine, **95**, under ESI+ condition in the nebuliser.

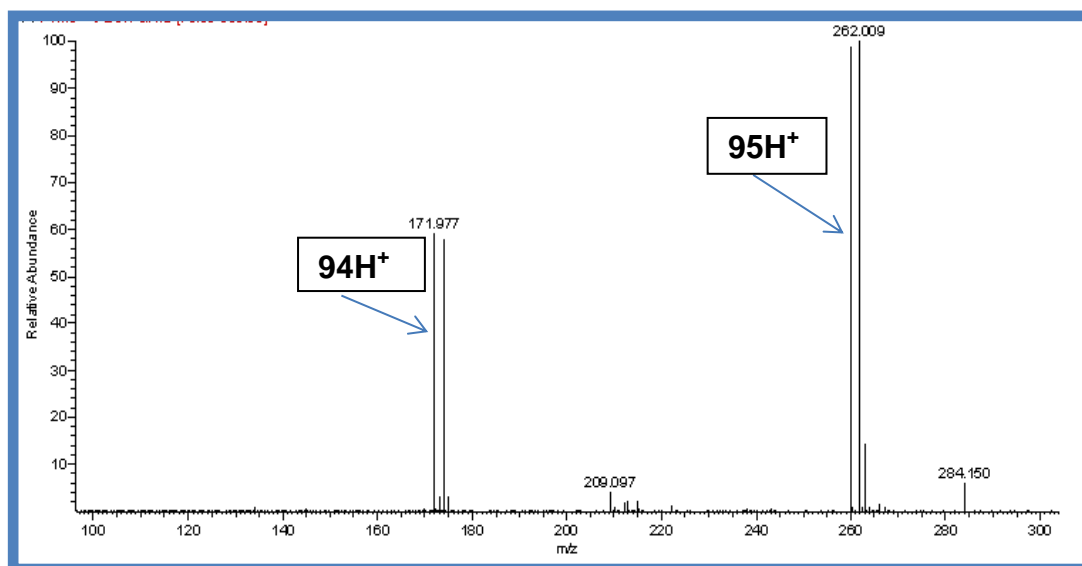
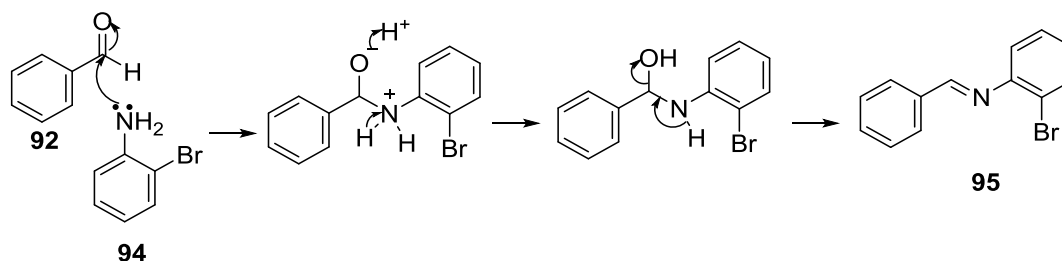

Figure (18): LC-MS of a nebulised mixture of **93** and **94**.

The ions at m/z 260 and 262 may be explained in terms nucleophilic attack of aniline on protonated benzaldehyde, to form a protonated tetrahedral adduct, which then undergoes proton transfer, followed by elimination of water, to generate the protonated imine. This proposed mechanism, see Scheme (38), corresponds precisely to the well-documented means by which aldehydes condense with amines to form imines in solution, under either acid- or base-catalysed conditions. Alternatively, a radical mechanism may operate, as it appears to be probable in the dimerisation of indoles discussed in the previous chapter.



Scheme (38): Mechanism for the formation of the imine.

Although imine formation in solution is rather more easily achieved than many organic chemists realise, the rate at which the signals corresponding to the protonated imine are formed under ESI⁺ conditions was exceptionally rapid. Indeed, attempts to make a more detailed study of this reaction and to exploit its synthetic potential by spraying mixtures of aldehydes and amines in solution through an “offline” nebuliser were thwarted by persistent blockages in the capillary inlet system. Provided that these technical problems can be overcome, the synthesis of imines in droplets, such as those produced in a nebuliser, has obvious potential, particularly in cases in which the corresponding condensation in conventional

“condensed phase” conditions are slow or in which one reactant or the product is acid sensitive.

5.3.2. Formation of Quinoxalines under positive Electrospray conditions

In order to explore the scope of forming covalent bonds under ESI+ condition in the nebuliser, the formation of quinoxalines, **97**, was investigated. Quinoxalines were chosen for two reasons, firstly like indoles, they are formally derived by fusing a benzene ring with an aromatic nitrogen heterocycle (in this case, pyrazine, as opposed to pyrrole) to produce a bicyclic aromatic nucleus. Secondly, the formation of quinoxalines under ESI+ will involve the formation of two C=N bonds as opposed to imines which only requires the formation of one C=N bond. Furthermore, quinoxalines are used as precursors in organic synthesis and they also have biological relevance. For instance, the peptide antibiotic echinomycin, **96**, contains two quinoxaline subunits. Owing to their applications in many fields, there is a constant search for better methods of synthesising quinoxalines. The most common method entails condensing the requisite starting materials, in this case the 1,2-dicarbonyl compound, **98**, with 1,2-phenyldiamine, **99**, at elevated temperature in the presence of a catalyst.

Retrosynthetic analysis by disconnection of both the C=N bonds reveals an *o*-phenylenediamine and a benzil, Scheme (39). The corresponding forward reaction, condensation of the requisite *o*-phenylenediamine and the appropriate benzil, offers a general synthetic route to quinoxalines. Consequently, a study of the possibility of effecting the condensation of phenylenediamines and benzils under ESI+ conditions is a

logical extension of the themes explored in the dimerisation of indoles and the synthesis of imines.

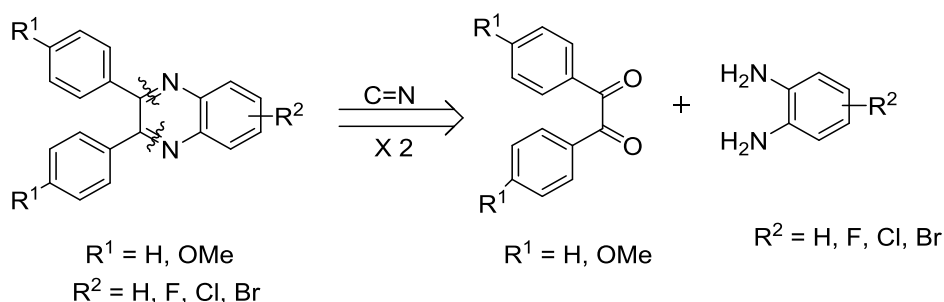

Scheme (39): Retrosynthetic analysis.

In practice, a range of 2,3-diphenylquinoxalines could be formed by infusing an equimolar amount of *o*-phenylenediamine and benzil in solution in methanol, through the nebuliser, collecting the eluent and analysing it by LC-MS. In addition, the protonated quinoxaline was directly observed in the ESI+ spectrum of a solution of the two starting materials, Figure (19).

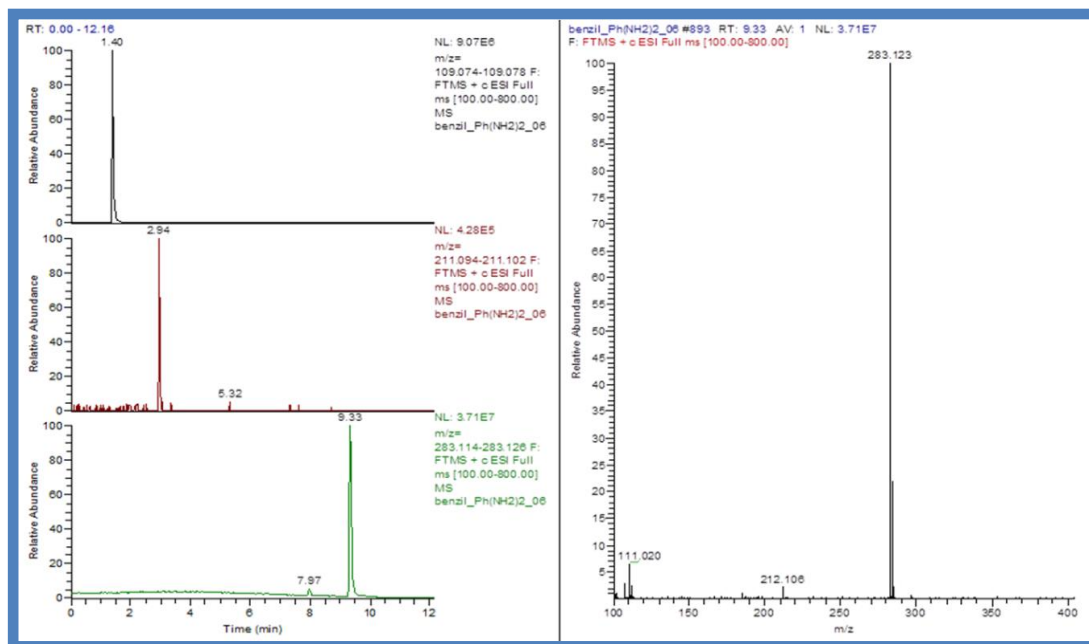
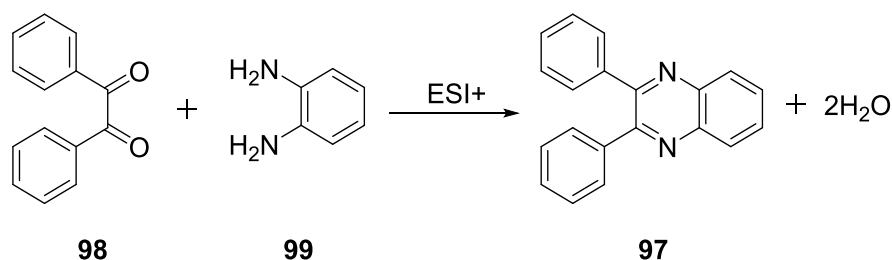

Figure (19): LC-MS of a nebulised solution of a mixture of **98** and **99**.

Thus, the ESI+ spectrum of a mixture of benzil and *o*-phenylenediamine, showed a peak at *m/z* 283 corresponding to protonated 2,3-diphenylquinoxaline, **97**, which was produced by condensation of the diketone, **98**, and the diamine, **99**, with elimination of two water molecules, Scheme (40).



Scheme (40): Formation of **97** under ESI+.

Further investigation revealed that the formation of protonated quinoxalines, QH⁺, in the mass spectrometer by this method is general, Table (20). The following abbreviation defines the structure of starting materials and the product; for the starting materials "B" denotes benzil and "P" denotes phenylenediamine; a suffix attached to either B or P indicates which substituents, if any, are present in either component. Thus P and B(OMe)₂ corresponded to the parent *o*-phenylenediamine, **99**, and 4,4'-dimethoxybenzil, **100**, respectively. Similarly, QH⁺, denotes the corresponding protonated quinoxaline, **101**, Scheme (41).

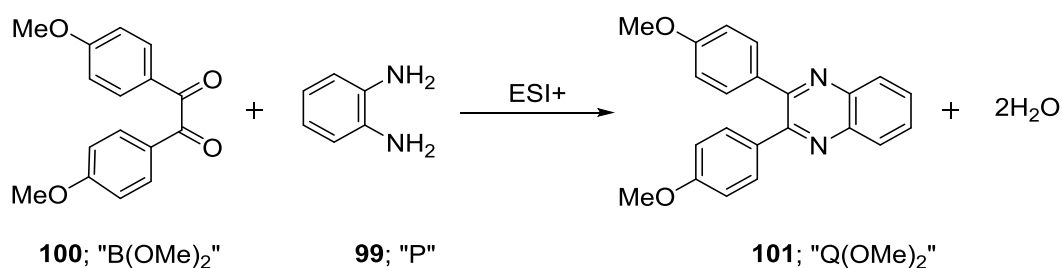

Scheme (41): Formation of quinoxaline, Q(OMe)₂.

When **P** and **B** components react to form \mathbf{QH}^+ under ESI+ conditions, adducts corresponding to the intermediate stages of condensation ($[\mathbf{Q(OMe)}_2\mathbf{H}+2\mathbf{H}_2\mathbf{O}]^+$ and $[\mathbf{QH}+\mathbf{H}_2\mathbf{O}]^+$) were also detected. Thus, when **99** condenses with $\mathbf{B(OMe)}_2$, **100**, the $[\mathbf{Q(OMe)}_2\mathbf{H}+2\mathbf{H}_2\mathbf{O}]^+$ and $[\mathbf{Q(OMe)}_2\mathbf{H}+\mathbf{H}_2\mathbf{O}]^+$ adducts, **103** and **102**, appear at m/z 379 and 361, respectively, with $\mathbf{Q(OMe)}_2\mathbf{H}^+$, **101**, itself at m/z 343, see Figure (20). Parallel trends were observed in the ESI+ spectra of a mixture of a range of *o*-phenylenediamines and benzils, see Table (20).

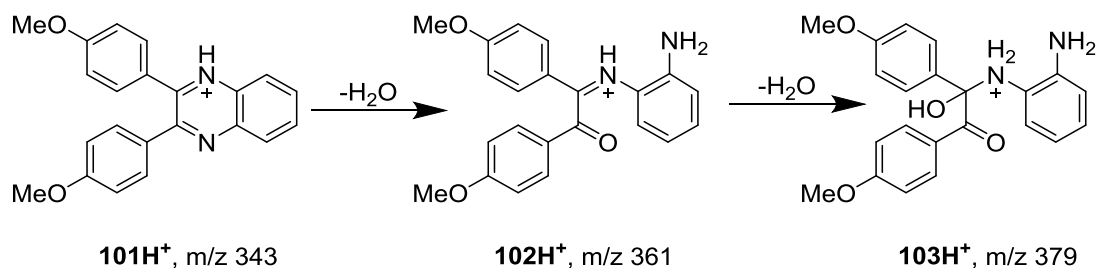
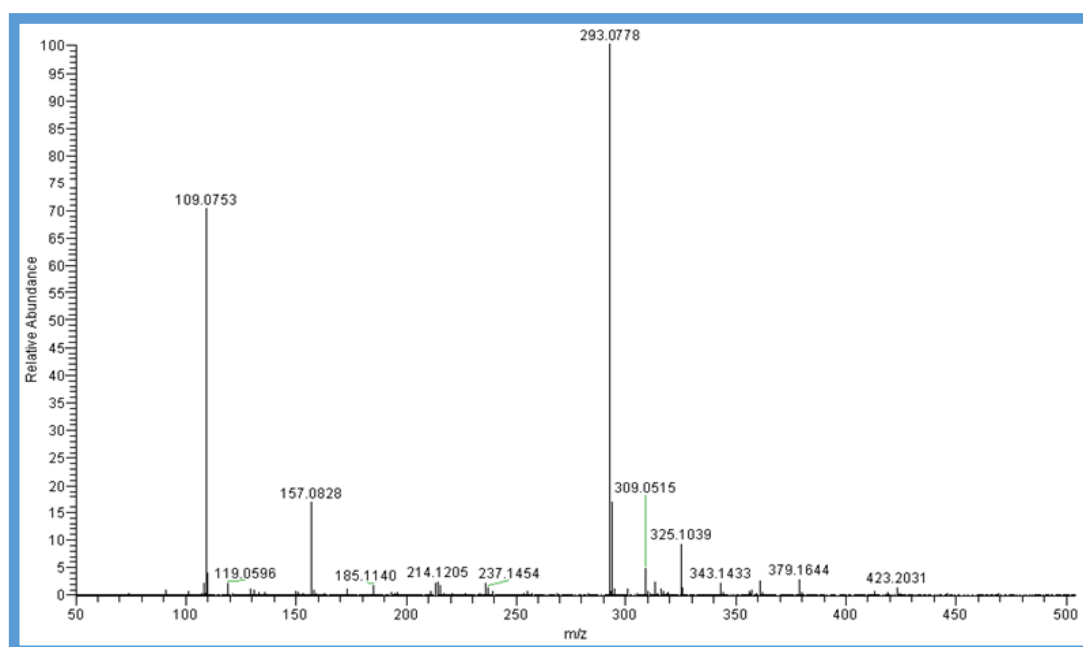
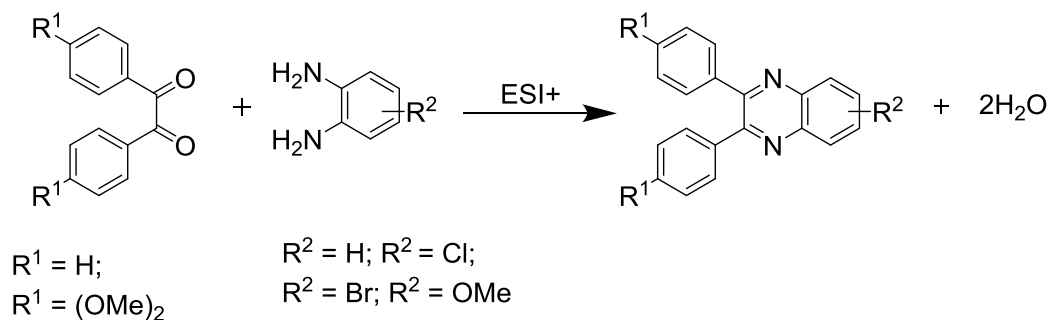

Figure (20): ESI+ spectrum of a mixture of **P** and $\mathbf{B(OMe)}_2$.

Table (20): Summary of the important signals in the ESI+ spectra of mixtures of phenylenediamine, **P**, and benzil, **B(OMe)₂**.

PCI + B(OMe) ₂		PBr + B(OMe) ₂		PCI + B	
m/z	Assignment	m/z	Assignment	m/z	Assignment
377	Q(OMe) ₂ CIH ⁺	421	Q(OMe) ₂ BrH ⁺	317	QCIH ⁺
395	[Q(OMe) ₂ CIH+H ₂ O] ⁺	439	[Q(OMe) ₂ BrH+H ₂ O] ⁺	335	[QCIH+H ₂ O] ⁺
413	[Q(OMe) ₂ CIH+2H ₂ O] ⁺	457	[Q(OMe) ₂ BrH+2H ₂ O] ⁺	353	[QCIH+2H ₂ O] ⁺

Further evidence to support a mechanism involving nucleophilic attack of the phenylenediamine on the protonated benzil was provided by high resolution mass spectrometry and analysis of collision-induced dissociation (CID) spectra. For example, in the condensation of **99** with **100** under ESI+ conditions, the ions at m/z 343, 361, and 379 had the formulae C₂₂H₁₉N₂O₂, C₂₂H₂₁N₂O₃, and C₂₂H₂₃N₂O₄ which precisely matched those expected for **Q(OMe)₂H⁺**, **[Q(OMe)₂H+H₂O]⁺** and **[Q(OMe)₂H+2H₂O]⁺**, respectively. Moreover, the CID spectrum of the ion at m/z 343 was a good match for that generated by protonation of an authentic sample of **Q(OMe)₂**, **101**, obtained by the conventional condensation of **P**, **99**, and **B(OMe)₂**, **100**, in solution. Finally, in this connection, the CID spectra of both the intermediate ions, **[Q(OMe)₂H+2H₂O]⁺**, **99**, and **[Q(OMe)₂H+H₂O]⁺**, **100**, formed under ESI+ conditions showed a strong tendency to fragment by eliminating water, thus supporting the proposal that these species were genuine intermediates in the condensation of **P**, **99**, and **B(OMe)₂**, **100**.



Scheme (42): Formation of quinoxalines under ESI+ condition.

Attempts to probe the influence of substituents on either **P** or **B** on the efficiency of the condensation under ESI+ conditions gave interesting, if only qualitative, results. The presence of an electron attracting fluoro or chloro substituent (usually in the 4-position) in the phenylenediamine ring appeared to have a detrimental effect on the condensation; conversely, the condensation appeared to be favoured by an electron donating methoxy substituent in this component. Similarly, the presence of an electron attracting fluoro or chloro substituent in the benzil (typically at the 4-position) appeared to favour the condensation, which perhaps proceeded less effectively if there was an electron donating methoxy group in this component. These effects are consistent with a mechanism involving nucleophilic attack of the phenylenediamine on the protonated benzil because electron attracting or releasing substituents would be expected to reduce and increase, respectively, the nucleophilic properties of the phenylenediamine. Similarly, electron attracting and releasing substituents in the benzil would be expected to reduce and increase, respectively, the electrophilicity of the protonated benzil. Unfortunately, however, other factors, including the varying solubility of the components, complicate this analysis.

Thus, the solubility of 4,4'-dibromobenzil in methanol was so low that condensations with this benzil derivative were very difficult to study. In addition, when assessing the electrophilic properties of the benzil, it is necessary to consider the possibility that protonation of 4,4'-dimethoxybenzil would be favoured by the electron releasing methoxy groups, thus making it easier to generate a reactive intermediate that would be the case for the parent benzil. This factor might offset, or even override, the effect of the methoxy groups in reducing the electrophilicity of the protonated benzil.

Despite the complications in reaching firm conclusions about the role of substituents on the phenylenediamine and benzil on the efficiency of the condensation to produce the protonated quinoxalines under ESI+ conditions, it is clear that the formation of C=N bonds is greatly accelerated compared to the situation in solution. Whereas condensation of phenylene diamine with benzil in solution typically requires heating and time (up to several hours in some cases, partly because of low solubility in protic solvents such as ethanol), the corresponding process under ESI+ conditions appears to occur almost instantaneously. Provided that certain technical challenges can be overcome, the potential for synthesising nitrogen heterocycles by accelerated formation of C=N bonds in droplets such as those formed in the nebuliser is obvious.

5.6. Conclusion

The effects uncovered when studying the novel dimerisation of indoles that is discussed in the previous chapter have more general application, especially in the formation of C=N bonds, both in acyclic systems (imines)

and in creating rings (as illustrated in the formation of protonated quinoxalines from the constituent components, phenylenediamines and benzils). At least some of these condensations appear to bear a significant resemblance to the corresponding processes in solution, as illustrated by the influence of substituents on each component. Not only are these discoveries mechanistically interesting, they also have clear synthetic potential.

6. SYNTHESIS OF 1,1'-BISINDOLES

6.1. Background

In view of the potential of preparing covalent bound dimers from indoles under ESI+ conditions, the natural occurrence, biological activity and the synthesis of bisindoles by conventional routes were briefly considered. The range of these dimeric species includes “open” and “fused” (macrocyclic) systems; moreover, much attention has been focused on certain bisindoles because of their biological activity.^{174, 175 176}

For example, Topsentin, **104**, an open system bisindole alkaloid with a keto and an imidazole entity forming a link between the two indole rings connected through their 3-positions.^{176, 177} It was isolated from a class of marine sponges; its biological properties encompass antitumor,¹⁷⁸ antiviral, antifungal, antibacterial, and anti-inflammatory activity.¹⁷⁴ Other open bisindoles include caulepin, hamacantins¹⁷⁹ and Hyrtiosin B, Figure (21).

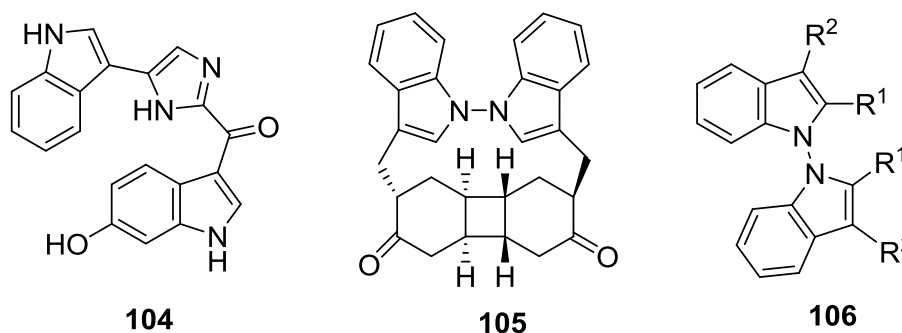
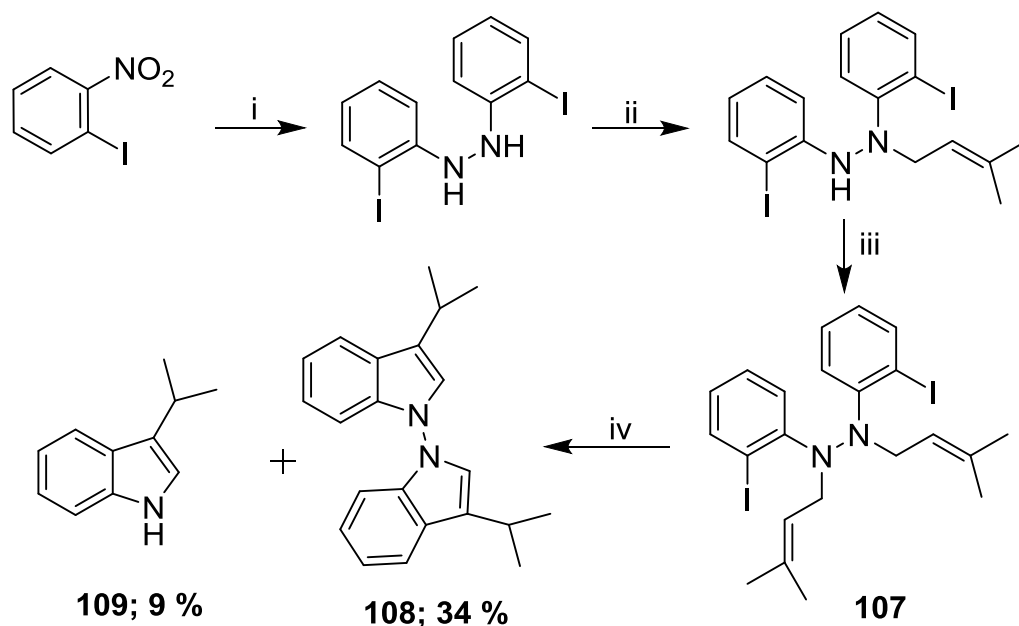

Figure (21): Examples of bisindoles and 1-1'-bisindoles.

Schischkiniin, **105**, which was isolated from *Centaurea schischkinii* and first reported in 2005,¹⁸⁰ is an interesting case of a fused bisindole, Figure (21). It contains an usual 1,1'-bisindole group embedded in a 14-membered macrocycle.¹¹⁵ The 1,1'-bisindoles, **106**, are heterocyclic

compounds containing two indole units linked through the two nitrogen atoms. This class of bisindoles would be particularly attractive for synthesis under ESI+ conditions if it were possible to induce dimerisation by bonding of the two nitrogen atoms in monocyclic indoles.

Numerous methods are available for the preparation of topsentin, **104**, and other related open ring systems such as notopsentins, including cross coupling,^{181, 182} rearrangements^{183, 184} and the use of 3-aminoacetylindole as a precursor (synthesised in three step from indole).¹⁷⁶ However, practical synthetic methods are quite limited for the 1,1'-bisindole ring system: there appears to be only one general method¹¹⁵ for the preparation of this class of compound. This approach, which entails the introduction of the key nitrogen atom(s) in the early stage of the synthesis, involves two simultaneous Mori-Ban cyclisations (intramolecular Heck) of hydrazobenzenes. The precursor hydrazobenzenes, **107**, are obtained from two dialkylation steps.^{185, 186} Unfortunately, there is a serious problem with this method: poor yields (typically less than 35%) occur because two products (that arising from the normal Heck coupling, **108** and another resulting from N-N cleavage, **109**) may be formed, Scheme (**43**). Consequently, the invention of a method that would lead mainly or exclusively to the desired product will be of significant practical value.



Scheme (43) *Reagents and conditions:* i) Zn, aq. NaOH, 54 % ii) LDA (1.2 equ.), THF, (CH₃)₂CHCHCH₂Br iii) KOH (2 equ.), DMSO, (CH₃)₂CHCHCH₂Br, 99 % iv) Pd(OAc)₂, TBACl, HCO₂Na, NMP, 16 hr.

6.2. Synthetic strategy

The initial retrosynthetic analysis is shown in Scheme (44): disconnection of both C-N bonds to the carbocyclic ring of **106** revealed the dibrominated azine derivative, **110**. Further disconnection (C=N) revealed two molecules of the corresponding aryl ketones, **111**, **115** and **120**.

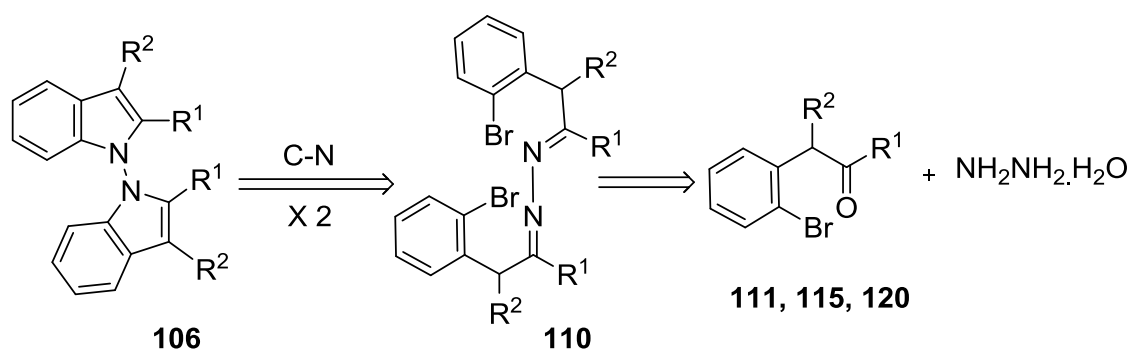

Scheme (44): Retrosynthetic analysis of 1,1'-bisindole.

It was envisaged that the proposed synthetic sequence would involve intramolecular copper mediated C-N arylation of the bromoazine derivative,

110. It was anticipated that **110** itself would be accessible by condensing the requisite *o*-bromoketone, **111**, with hydrazine monohydrate (NH₂NH₂·H₂O). These 2-bromoarylketones, which are readily accessible via various routes, such as palladium coupling,^{187, 188} have previously been used as starting materials in the synthesis of 2-substituted indoles by copper catalysed reactions with ammonia or alkyl amines.¹⁸⁹ This “one pot” methodology involved formation of the intermediate imine-enehydrazine, **113** (derived from treatment of the aryl ketone, **112** with the appropriate amine), which is reacted with cuprous iodide (CuI) to give the desired indole, **114**.^{189, 190} Furthermore, palladium catalysed intramolecular *O*-arylation of 2-bromoaryl ketones has been reported to form the corresponding benzofuran. For example, when α -(*o*-bromophenyl)cyclohexanone, **115**, was treated with bis(dibenzylideneacetone)palladium(0), (Pd(dba)₂) in the presence of DPEphos and caesium carbonate in toluene, the tricyclic product, 1,2,3,4-tetrahydro-dibenzofuran, **116**, was obtained in 95% yield, Scheme (45).¹⁸⁷

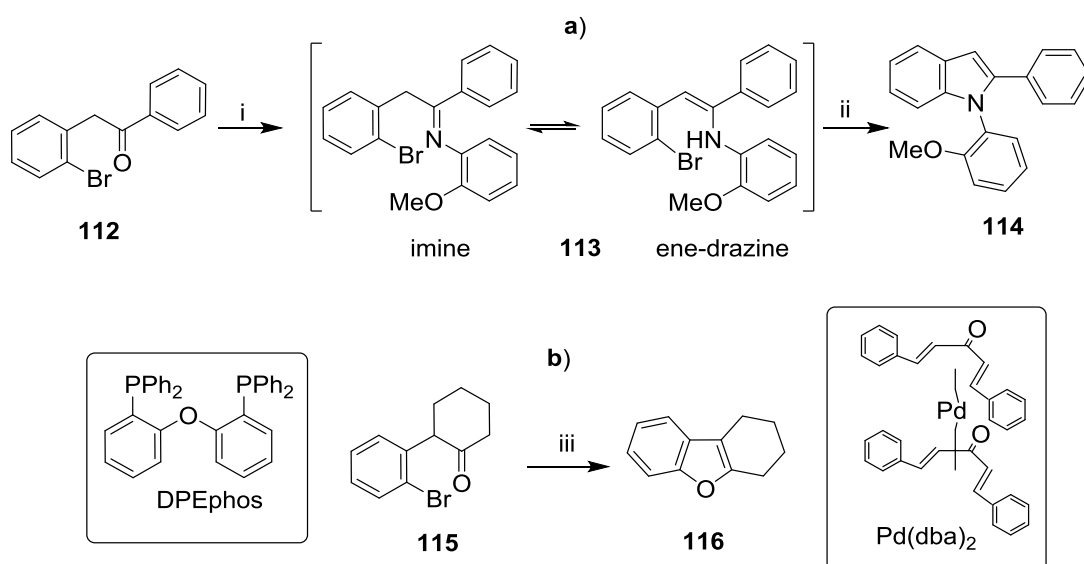

Scheme (45) *Reagents and conditions:* i) 2-MeOPhNH₂, Ti(O^{*t*}Bu)₄, 60-140 °C, 10 hr; ii) CuI (10 mol%), Cs₂CO₃ (2 equ.), DMA, 125 °C, 10 hr, 86%; iii) Cs₂CO₃, Pd(dba)₃, DPEphos, toluene, 110 °C, 95%.

6.2.1. Synthesis of 2-bromo substituted Ketone

The synthetic work described in this chapter began with the reaction of o-bromophenylacetic acid, **117**, with thionyl chloride (SOCl_2) to give the corresponding acid chloride, **118**, which was not isolated but treated directly with N,O-dimethylhydroxylamine in the presence of an acid scavenger (pyridine) to provide the corresponding Weinreb amide, **119**. The reaction of **119** with phenylmagnesium bromide (PhMgBr) in THF resulted in the formation of a chelated adduct which is stable under the reaction conditions, thus preventing elimination of $[\text{MeO}(\text{Me})\text{N}]^-$ to regenerate the carbonyl group, which would permit nucleophilic addition of a second mole of PhMgBr ; however, this tetrahedral adduct collapsed to the desired ketone, **112**, during the standard aqueous workup, Scheme (46).

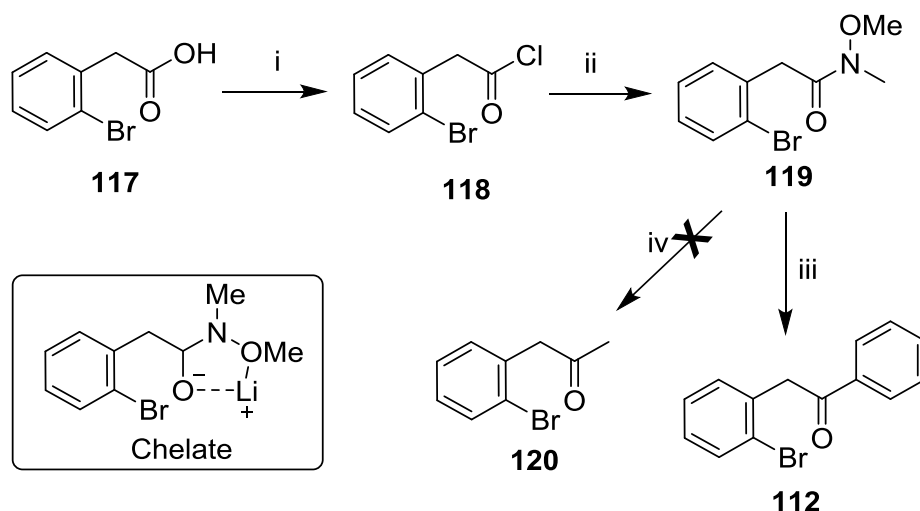

Scheme (46) *Reagents and conditions:* i) SOCl_2 ; ii) $\text{CH}_3\text{NHOCH}_3, \text{HCl}$, pyridine, CH_2Cl_2 , 0°C ; iii) PhMgBr , THF, 0°C , 40 mins; iv) MeLi , THF, 0°C .

In an analogous manner to the formation of **112**, the synthesis 1-(2-bromophenyl)-propan-2-one, **120**, was attempted by treating the Weinreb amide, **119**, with the organometallic reagent, methyl lithium (MeLi), in THF at

0 °C, Scheme (46). It was hoped that the initial adduct formed by addition of one mole of MeLi would also be sufficiently stable to prevent elimination of $[\text{MeO}(\text{Me})\text{N}]^-$ and prevent the regeneration of an electrophilic carbonyl group, so that an aqueous workup would afford the desired ketone, **120**. However, NMR analysis of the yellow oil obtained from this synthesis showed a mixture of products which could not be successfully separated. It was, therefore, concluded that the synthesis of **120** via this method might prove difficult.

In order to investigate other routes to **120**, *o*-bromophenylacetic acid, **117**, was treated with acetic anhydride, **121**, in the presence of a suitable salt of acetic acid (sodium acetate) in a process that bears a superficial resemblance to the Perkin reaction. Acetic anhydride was used in excess to avoid the formation of 1,3-bis(2-bromophenyl)-2-propanone, **122**. This method gave a moderate yield of the desired product, Scheme (47).

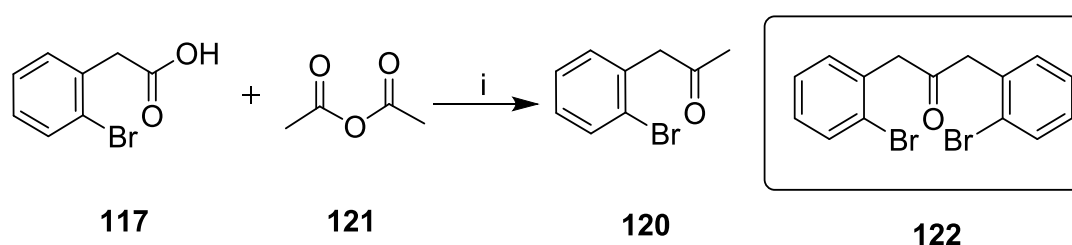

Scheme (47) *Reagents and conditions*: i) NaOAc, 140 °C, 40 hr, N₂, 35%.

Palladium coupling of 1-bromo-2-iodobenzene, **123**, with cyclohexanone, **46**, resulted in the C-C bond formation to give the related 2-bromophenyl ketone, α -(*o*-bromophenyl)cyclohexanone, **115**, in moderate yield, Scheme (48).

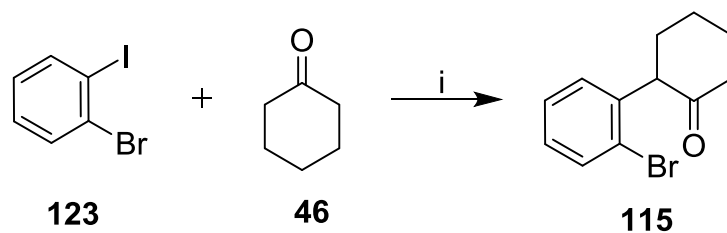

Scheme (48) *Reagents and conditions:* Cs₂CO₃, Pd(dba)₃, 1,4-dioxane, 80 °C, 24 hr, 71%.

6.2.2. Synthesis of the requisite Azines

The availability of these three *o*-bromoaryl ketones with various substituents (simple alkyl or aryl, represented by methyl, cycloalkyl or phenyl) permitted the next step in this synthetic route to be attempted. The diaryl species **112**, which was chosen as a model compound to optimise this route, was refluxed for several hours with NH₂NH₂.H₂O in ethanol in the presence of *p*-toluenesulphonic acid (TsOH) as a catalyst, Scheme (49).

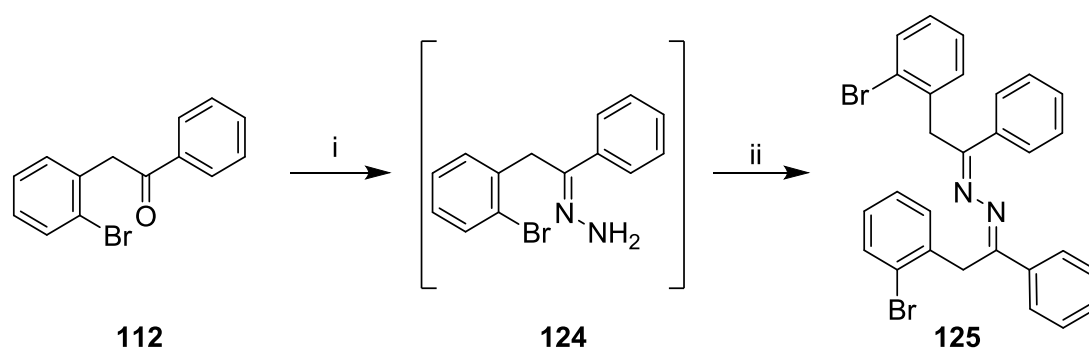

Scheme (49) *Reagents and conditions:* NH₂NH₂.H₂O, EtOH, *p*TsOH, 80 °C, 32%.

After monitoring the reaction by TLC, the resultant yellow oil obtained upon completion was analysed: ¹H NMR showed a broad singlet at 5.4 ppm integrating for 2 protons that could be assigned to the exchangeable protons of the NH₂ group; the IR spectrum also confirmed the presences of an NH₂ group (3378 and 3285 cm⁻¹). These data showed that the intermediate

enehydrazine, **124**, was obtained. In order to obtain the desired azine, **115**, this enehydrazine was refluxed in ethanol with an equimolar quantity of the parent ketone, **112**. The IR spectrum of the product obtained by this means showed the disappearance of the N-H signal that was associated with the amino group in **124**. The ESI+ mass spectrum, Figure (22), showed an MH^+ peak at m/z 545, accompanied by the expected signals at m/z 547 and 549 (the $^{81}Br_1$ and $^{81}Br_2$ isotope satellites, respectively, of MH^+) with relative intensities in the ratio 1:2:1, thus confirming the presence of two bromine atoms in the molecule. Furthermore, similar signals with intensities in the ratio 1:2:1, corresponding to $[M+Na]^+$, were present at m/z 567, 569 and 571, thus corroborating the deduction that the product contained two bromine atoms, Figure (22).

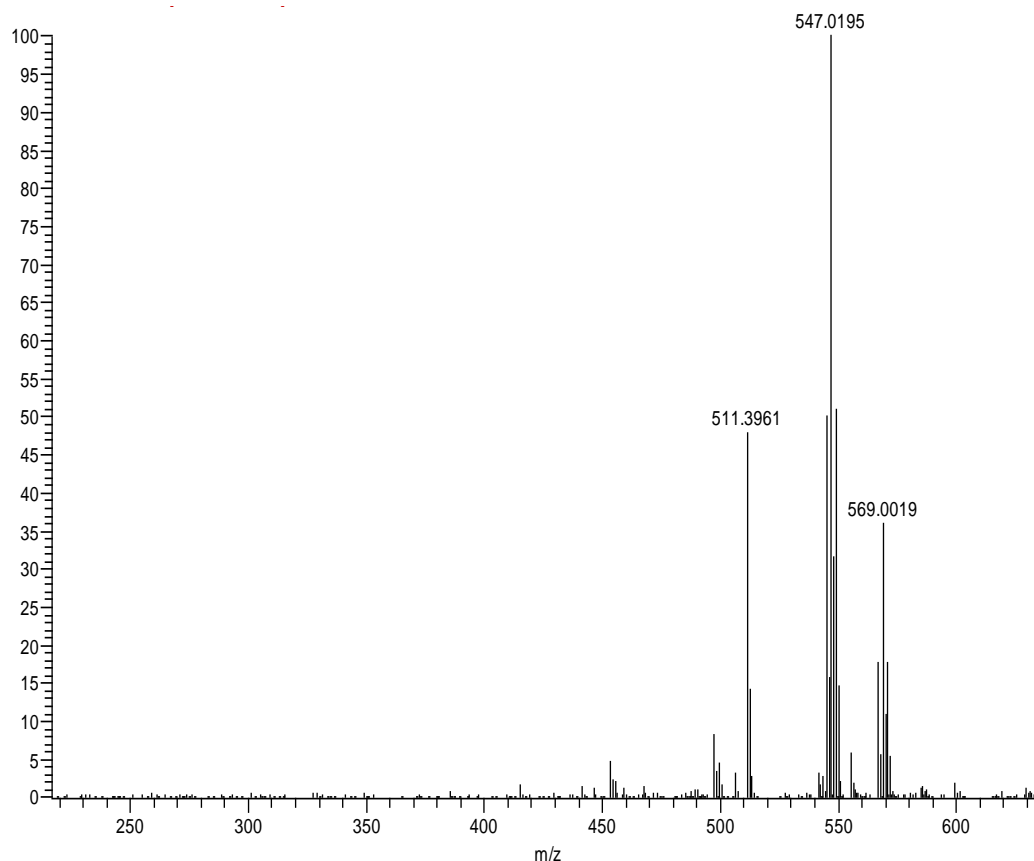

Figure (22): ESI+ Mass spectrum of **124**.

In addition, high resolution data confirmed that molecular formula of this compound was $C_{28}H_{22}N_2Br_2$. The 1H NMR spectrum showed a singlet at 4.5 ppm, together with a series of signals for the aromatic protons in the region 6.9-8.0 ppm. The integration of the signals for aromatic protons in this region corresponded to 9 protons, which reflects the symmetry of the azine, **125**, Figure (23).

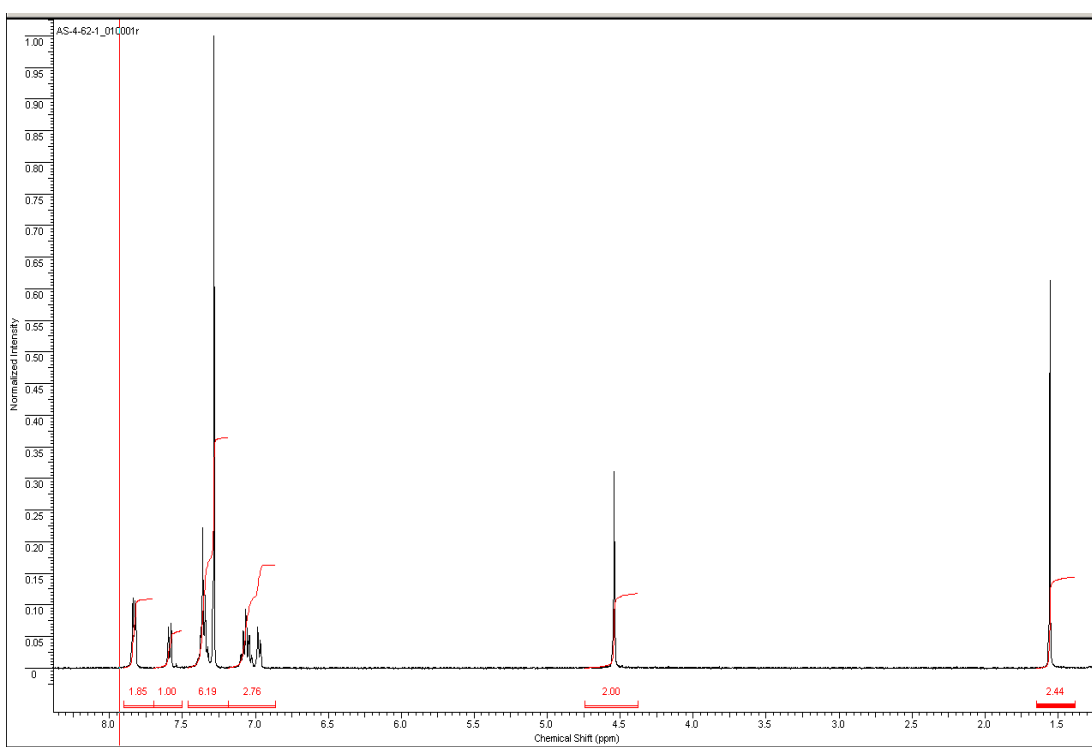
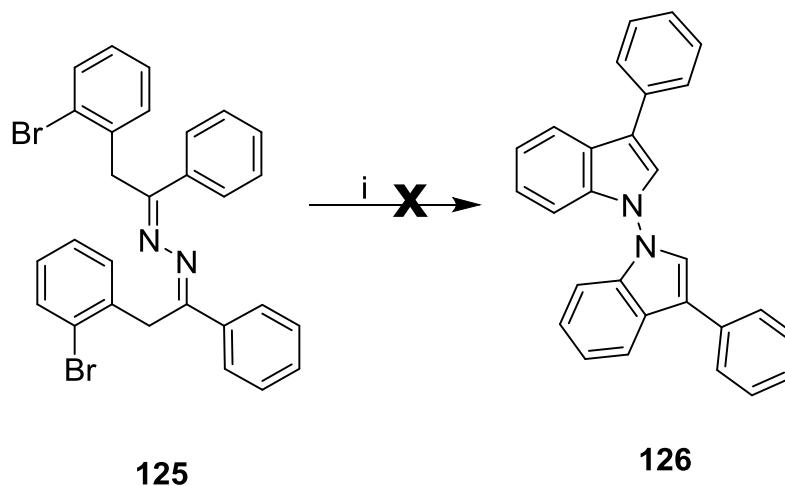

Figure (23): 1H NMR spectrum of **125**.

6.2.3. Copper mediated *N*-Arylation

Careful thought was given to choosing the most appropriate source of copper(I) and the associated base to maximise the prospects of facilitating the copper catalysed *N*-arylation. The chosen base was K_3PO_4 because it

had been reported to have been used successfully in the cyclisation of indoles; CuI was used as the source of copper. The reaction was attempted by refluxing **125** with CuI in dimethylformamide (DMF) with CuI and the base under N₂, Scheme (50).



Scheme (50) *Reagents and conditions:* i) CuI, K₃PO₄, DMF, 110 °C, N₂, 90 min.

Unfortunately, the ¹H NMR spectrum of the reaction mixture indicated that it was composed mainly of starting material; thus, the signal at 4.5 ppm, which had been assigned to the methylene protons in the starting material, remained present. Although this outcome was disappointing, especially since time restraints prevented more extensive attempts to vary the reaction conditions, this exploratory work does show that there is potential to prepare novel bisindoles by this general route, provided that the final cyclisation can be effected in decent yield in comparatively mild conditions.

6.3. Conclusion

In summary, using this protocol the precursor dibrominated azine was synthesised in moderate yield in two steps via the intermediate hydrazone from the *o*-bromoaryl ketone. However, conditions for the final cyclisation step to form the bisindole are yet to be developed. In order to explore this methodology, a wide range of intermediate azines need to be synthesised.

7. BASE MEDIATED REARRANGEMENT OF 1-ACYLATED 2-METHYLINDOLES

7.1. Background

Following the exploratory work on synthesising bisindoles reported in the previous chapter, the possibility of preparing 2-substituted indoles by rearrangement of the corresponding 1-substituted isomers was considered. This idea was a logical extension of the overall scope of the project, which encompassed indoles in general. In addition, it was hoped that insight could be obtained that might be useful in future work on the synthesis of bisindoles.

Treatment with lithium diisopropylamine (LDA) had been reported to be an effective method for deprotecting 1-pivaloylindoles to give the parent heterocycles in excellent yield, Scheme (51).¹⁹¹

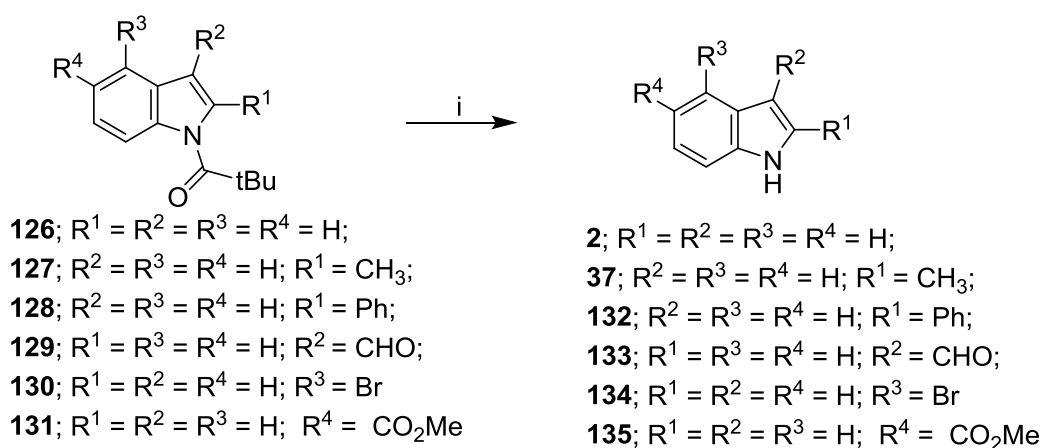

Scheme (51) *Reagents and conditions*: LDA (2 eq.), THF, 40–45 °C, 83–100%.

This procedure worked well not only for 1-pivaloylindole itself, but also for a variety of homologous species (**127**, **128**, **129**, **130** and **131**, respectively) derived from 2-methylindole, 2-phenylindole, 3-formylindole, 4-bromoindole, and 5-carbomethoxyindole. The compatibility of this deprotection with the presence of various substituents, including a bromine

atom and a formyl group, seemed to be quite promising. However, when the substituent was in the 2-position of the indole, thus increasing the steric hindrance towards nucleophilic attack on the carbonyl group of the pivaloyl substituent, only a moderate yield of the desired deprotected indole was obtained. Thus, treatment of 2-methyl-1-pivaloylindole, **127**, with LDA at 40–45 °C, produced only 33% of 2-methylindole, **37**, Scheme (52).

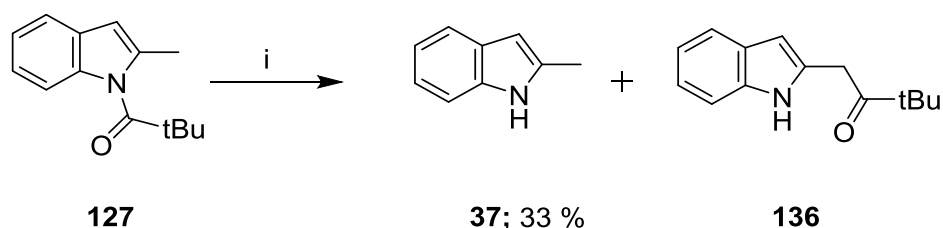

Scheme (52) *Reagents and conditions*: LDA (2 eq.), 40–45 °C.

This reduced yield reflects the competition between deprotection (arising by nucleophilic attack of the amide anion on the carbonyl group) and intramolecular pivaloyl transfer from nitrogen to position 2 [via the new possibility of deprotonation by the amide anion of the 2-methyl group to give a nucleophilic species that could attack the carbonyl group, to give 2-(3,3-dimethyl-2-oxopropyl)indole, **136**, Scheme (52)]. This observation, though unhelpful in the context of the original work,¹⁰⁵ offered a potential means of preparing indoles in which the methyl group in the 2-position has been elaborated by transfer of an acyl substituent that had originally been attached to the nitrogen atom.

7.2. Results

7.2.1. Preparation *N*-protected 2-methylindoles

A range of 2-methyl-1-alkoxycarbonylindoles, **137-141**, was prepared as starting materials to probe the viability of exploiting the rearrangement to prepare novel 2-substituted indoles. 2-methyl-1-(*t*-butoxycarbonyl)indole, **137**, was synthesised by treating 2-methylindole, **37**, with Boc₂O in THF in the presence of a catalytic amount of DMAP,¹⁹² Scheme (53). The desired *N*-protected indole was obtained in good yield. The spectroscopic data obtained for this product were identical to those previously reported.¹⁹³

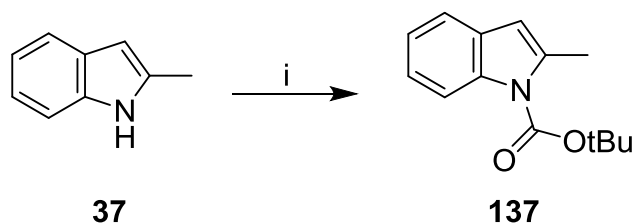

Scheme (53) *Reagents and conditions*: Boc₂O, THF, DMAP, RT, 90%.

The other *N*-protected 2-methylindoles (R¹ = OMe, OEt, Ph and CH₂Ph) were prepared via the reaction of 2-methylindole, **37**, with lithium hexamethyldisilazide (LiHMDS) as the base in THF, followed treatment with the appropriate chloroformate.¹⁹⁴ The desired compounds were obtained in excellent yield, Scheme (54).

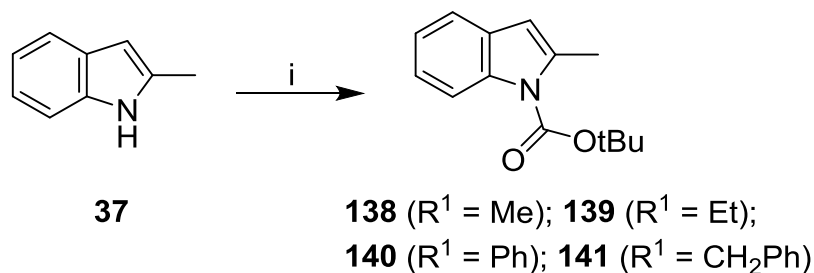

Scheme (54) *Reagents and conditions*: i) LiHMDS, THF, R¹OCOCI, -78 °C– rt, 93–99%.

7.2.2. Rearrangement

Preliminary studies established that the starting material that was accessible in the highest yield was 1-ethoxycarbonyl-2-methylindole, **139**; consequently, it was used for the initial exploratory work. Therefore, **139**, was treated with 2 equivalents of LDA in THF at -78 °C, in the hope of obtaining exclusively the 2-(carboethoxymethyl)indole, **142**, Scheme (55).

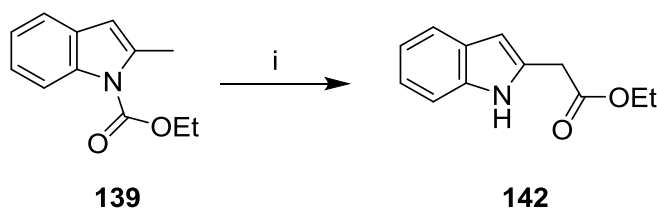

Scheme (55): Proposed route for the synthesis of **142**.

The reaction was monitored over 6 hr by TLC, which showed mainly the presence of starting material. The ¹H NMR spectrum of the product showed that some decomposition had also occurred. Decreasing the reaction time to an hour resulted in the formation of a mixture that was shown by NMR to consist predominantly of the starting material, **139**, the deprotected species, 2-methylindole, **37**, and the desired rearranged product, **142**. In order to ensure that the reaction proceeded to completion, the amount of LDA was increased to 4 equivalents. In the ¹H NMR spectrum of the material obtained in this manner, three singlet peaks were observed between 7.8 and 6.1 ppm: a broad singlet at 7.76 ppm was assigned to the N-H in 2-methylindole, **37**, whereas the two peaks at 6.42 and 6.13 ppm were ascribed to H-3 of the desired product, **142** and 2-methylindole, **37**, respectively. The presence of the two quartet signals (centred at 4.39 and 4.12 ppm) and two triplet peaks (centred at 1.39 and 0.87 ppm) showed the

presence of two ethyl groups, which possibly suggested the presence of the starting material. The spectrum also contained two singlet signals at 3.95 and 2.36 ppm; these peaks were assigned to CH₂ (H-9 of the product) and CH₃ (H-2 of 2-methylindole). Based on this analysis of the NMR spectrum, it was deduced that the material obtained in this reaction possibly consisted of three components: unreacted starting material, **139**, 2-methyl indole, **37** and the rearranged product, **142**. This interpretation was investigated by TLC, in which the material that had been analysed by NMR was run against 2-methylindole, **37**, and the starting material, **139**: only two spots were detected, corresponding to **37** and possibly **142**, but there was no trace of the starting material. The IR spectrum of the mixture showed two C=O stretching bands at 1729 and 1704 cm⁻¹, which is consistent with the presence of two carboethoxy groups. These results suggested that this reaction resulted in the formation of 2-methylindole and ethyl-2-(2-ethoxy-2-oxoethyl)-1*H*-indole-1-carboxylate, **143**. Based on the integration of the signals for H-3 at 6.42 and 6.13 ppm, only 33% of the mixture was **143**, Scheme (56).

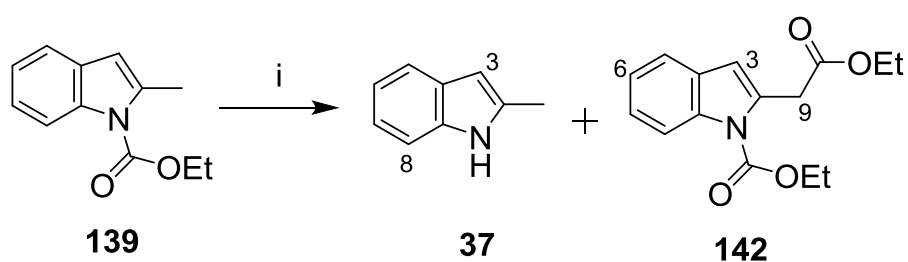

Scheme (56) *Reagents and conditions*: LDA (4 equ), THF, - 78 °C, N₂, 10 mins.

In the hope of increasing the yield of **143**, the base was added at a slower rate over a longer period of time (20 mins). The idea behind the slower addition was to ensure that only a small amount of LDA was available to induce the deprotection. This refinement, together with allowing the

temperature of the LDA to rise, increased the proportion of **143** in the product to approximately 50%, Figure (24 and 25). However, it did not prove possible to obtain a yield in excess of 50%.

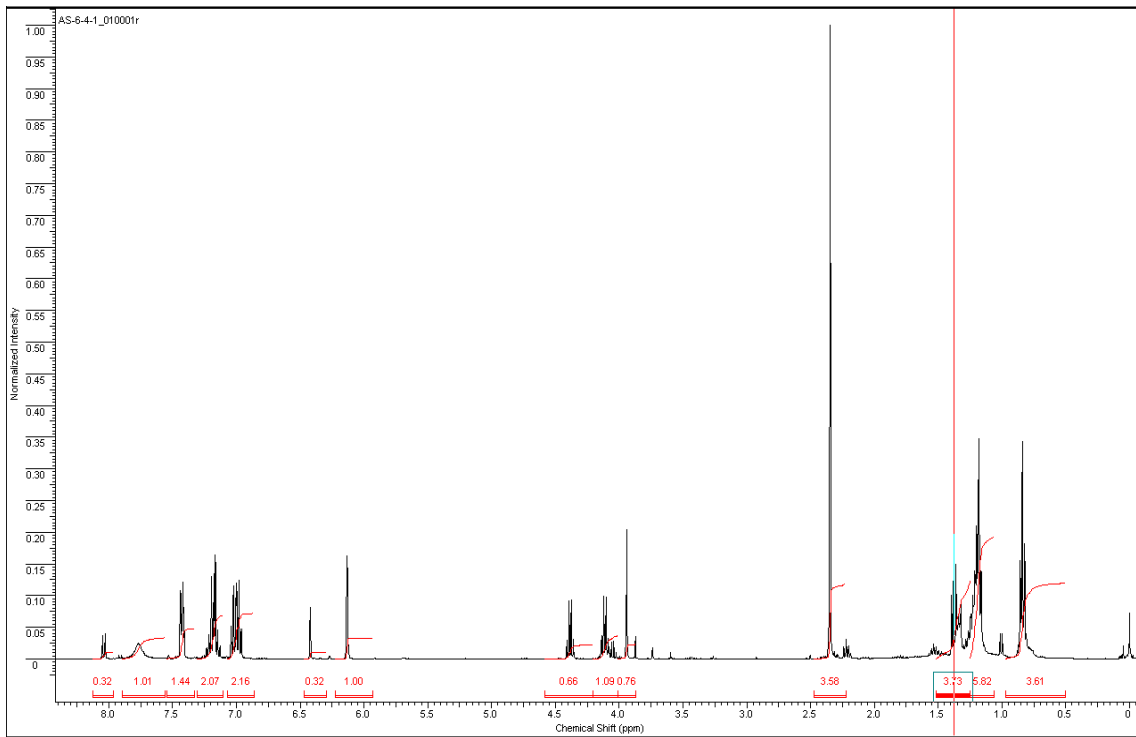

Figure (24): ¹H NMR spectrum of reaction mixture when the LDA was added fast.

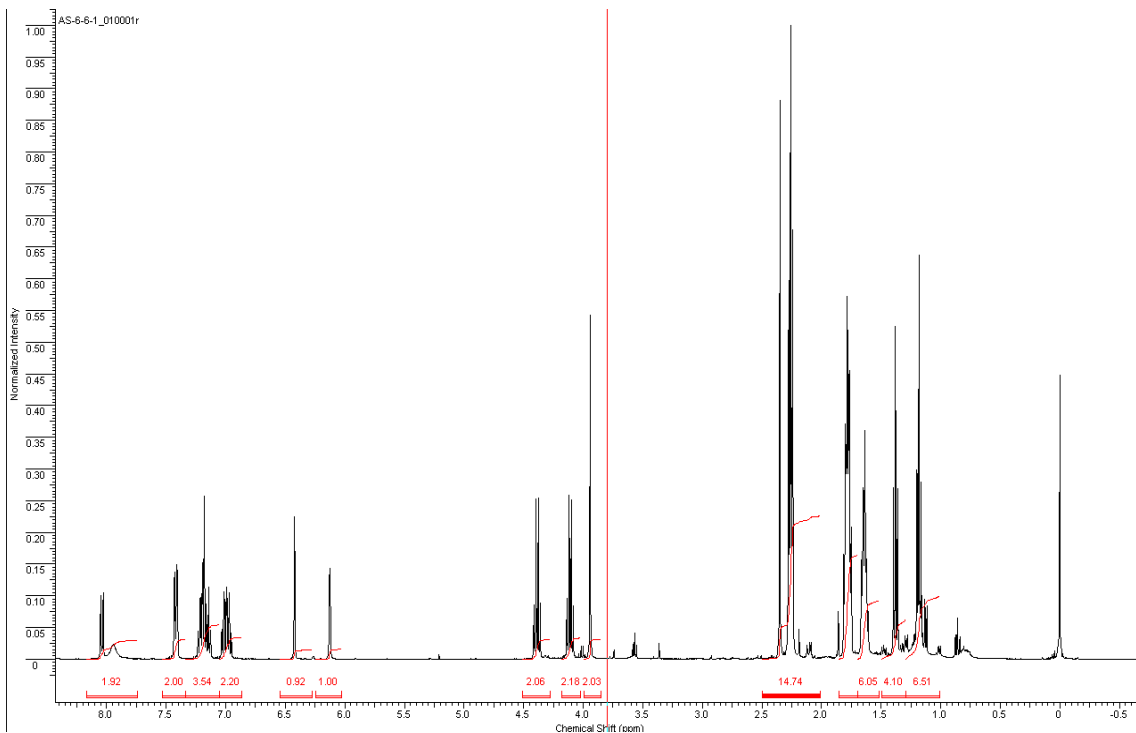

Figure (25): ¹H NMR spectrum for the reaction when the LDA was added slowly.

7.2.3. Attempts to optimise the Base

In order to attempt to optimise the reaction to improve the yield, alternative bases for the investigation were considered; eventually, *tert*butyllithium (*t*BuLi) was chosen, partly because it was assumed that this species would be more likely to function as a base (by deprotonation of the methyl group) than as a nucleophile. When 1-ethoxycarbonyl-2-methylindole, **139**, was treated with 2 equ of *t*BuLi in THF at -78 °C under an inert atmosphere, Scheme (57), and the reaction was monitored by TLC over a period of one hour, it was discovered that only one product was formed. Spectroscopic analysis of this product was informative. The presence in the IR spectrum of a sharp N-H band at 3378 cm⁻¹ indicated that the product contained a indole N-H (in other words, the *N*-carboethoxy group had been successfully removed), which strongly suggested the formation of either 2-methylindole, **37**, or the desired rearranged product, **142**, both of which contain an indole N-H. The ¹H NMR spectrum showed a broad singlet at 7.72 ppm, confirming the presence of an indole N-H, together with two doublet peaks, each of which integrated for one proton, and other peaks at 7.01, 6.11 and 2.30 ppm, which integrated for two, one and three proton(s), respectively. When the spectrum of the material obtained by treatment of **139** with *t*BuLi was compared with that of commercial 2-methylindole, the spectra were identical, Figure (26).

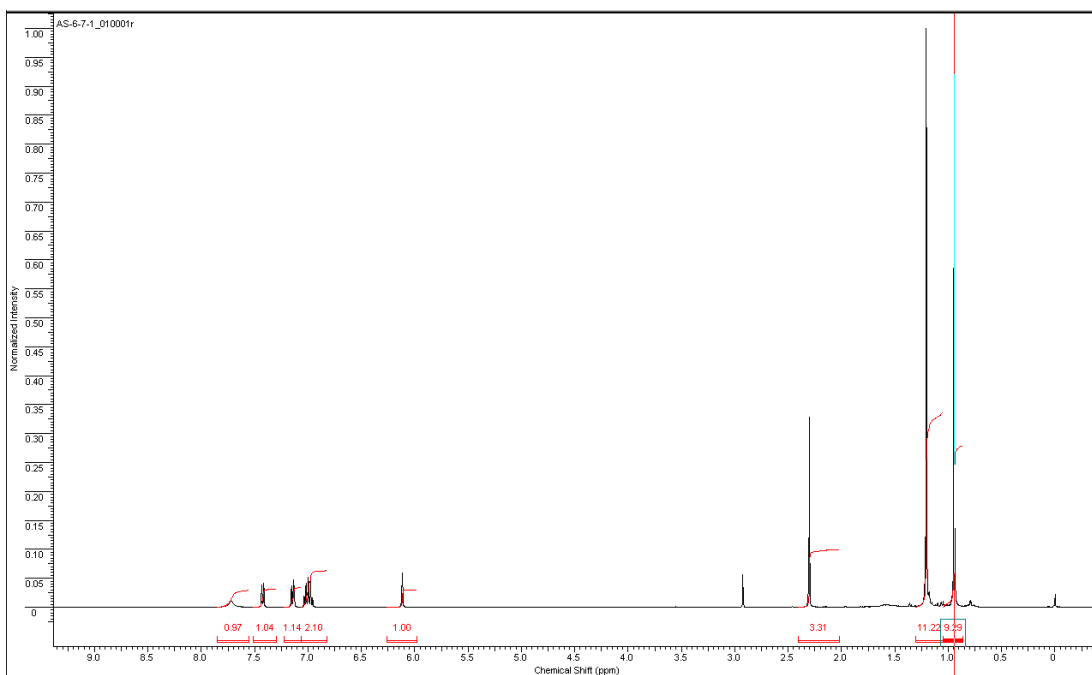
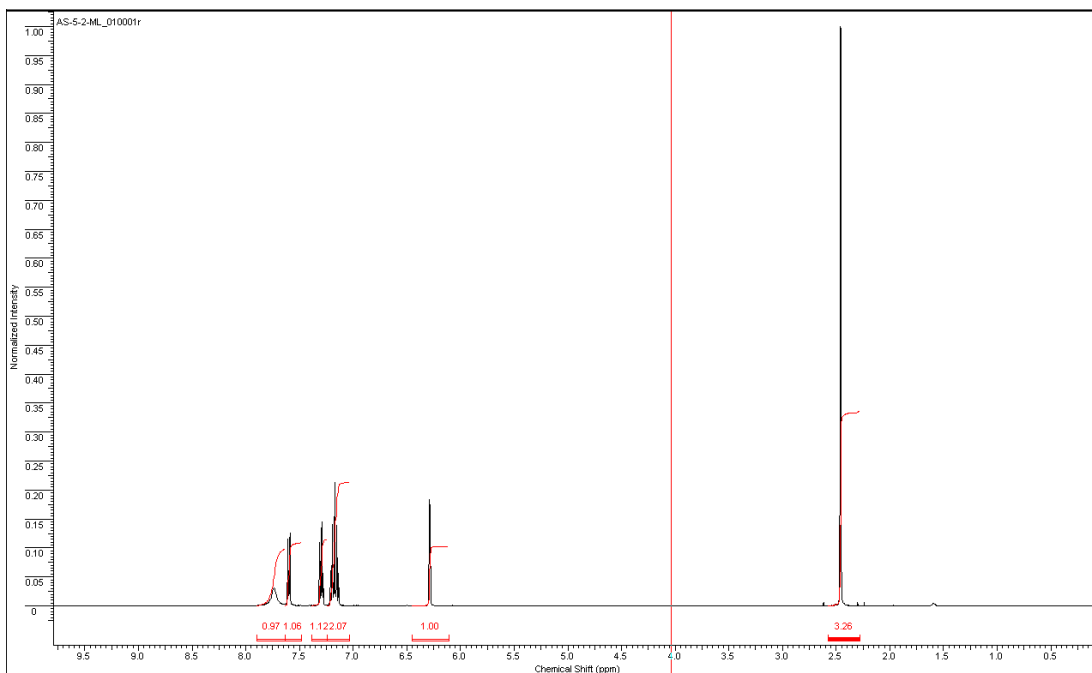
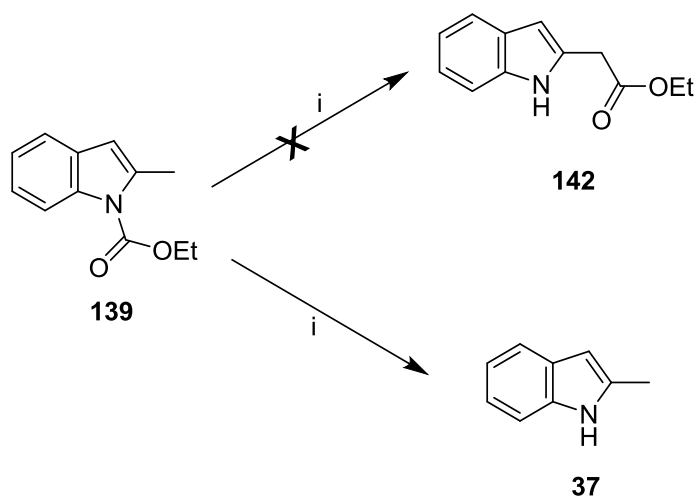

Figure (26): ^1H NMR spectra of 2-methylindole; top: commercial; bottom: obtained from reaction.

In summary, the spectroscopic data led to the conclusion that the reaction had been formed 2-methylindole in 92% yield. This result was completely unexpected: it had been anticipated that the use of *t*BuLi would decrease the percentage of deprotected material that was formed, whilst

raising the percentage of the desired product from the rearrangement; instead, the use of the stronger and more hindered base actually increased the proportion of deprotected material to such an extent that the undesired rearrangement that had been previously observed could now be effectively prevented. Although this finding was the opposite of the outcome required to secure the desired rearrangement, it did solve the problem encountered by the earlier workers who merely wished to deprotect the derivatives of 2-methyl indole.



Scheme (57) *Reagents and conditions:* *t*BuLi (2 equ), THF, - 78 °C, N₂, 92%.

Having established that optimisation of the conditions to induce the rearrangement at the expense of the deprotection would be more difficult than had been expected, attention was turned to why the yield obtained by using LDA could not be raised above 50%. Intramolecular transfer of the carboalkoxy group from the nitrogen atom to the carbon atom that was originally incorporated into the methyl group would entail the unfavourable formation of a four membered ring in the stepwise “addition-elimination” reaction. This process appears to be intuitively improbable. If it were to be

pre-empted by an intermolecular alternative, only half of the molecules of the 2-methylindole derivative would be converted into the rearranged species in which the 2-methyl group had been elaborated in the desired manner. The other half would merely be deprotected, thus limiting the maximum yield to 50%. In view of this consideration, no further attempts were made to optimise the yield of rearranged product.

Experiments in which a mixture of two different 1-acyl-2-methylindoles were treated with LDA resulted in the formation of “crossover products”, formed by transfer of the acyl group from one starting material to the anion derived by deprotonation of the methyl group of the other starting material. These “crossover” experiments confirmed that the rearrangement is intermolecular, rather than intramolecular. In view of these findings, no further attempts were made to optimise the yield of rearranged product.

8. NOVEL REARRANGEMENT OF SULPHONAMIDES

8.1. Introduction

Following the partial success in studying the transfer of a carboalkoxy group from the nitrogen atom of *N*-carboalkoxy indoles to the carbon atom the 2-position, via a rearrangement that proved to be intermolecular in nature, other potentially useful synthetic transformations of a similar kind were sought in order to extend the theme of acyl transfers in heterocyclic systems. It quickly became apparent that protection of certain substituents, including those such as an amino group with acidic hydrogen atoms, would be necessary in this part of the investigation.

Protecting group tactics play a vital role in organic synthesis. Protecting groups are required to prevent the occurrence of undesired side reactions. A good protecting group is easy to introduce, easy to remove and is stable to conditions of any reaction required for the elaboration of other parts of the molecule.¹⁹⁵

One particularly common method of protecting an amine is to convert it into the corresponding sulphonamide,¹⁹⁶ which is generally thought to be stable to many reagents,¹⁹⁷ including most strong bases.¹⁹⁸ The *p*-toluenesulphonyl (tosyl) derivatives are frequently used as a protecting group for amines and similar nitrogenous species, partly because of the crystalline nature of many of these sulphonamides (in contrast, a fair number of the corresponding benzenesulphonamides have much lower melting points, which makes them less easy to purify, characterise and manipulate). This approach is particularly common in synthetic routes to derivatives of arylamines, but it is also employed in the preparation of their aliphatic

counterparts. Arylamines have many applications in chemistry, including the production of diazo dyes¹⁹⁹⁻²⁰¹ and the synthesis, via the corresponding diazonium salts, of a huge range of aromatic compounds with a wide range of functional groups in a specific position.^{202, 203}

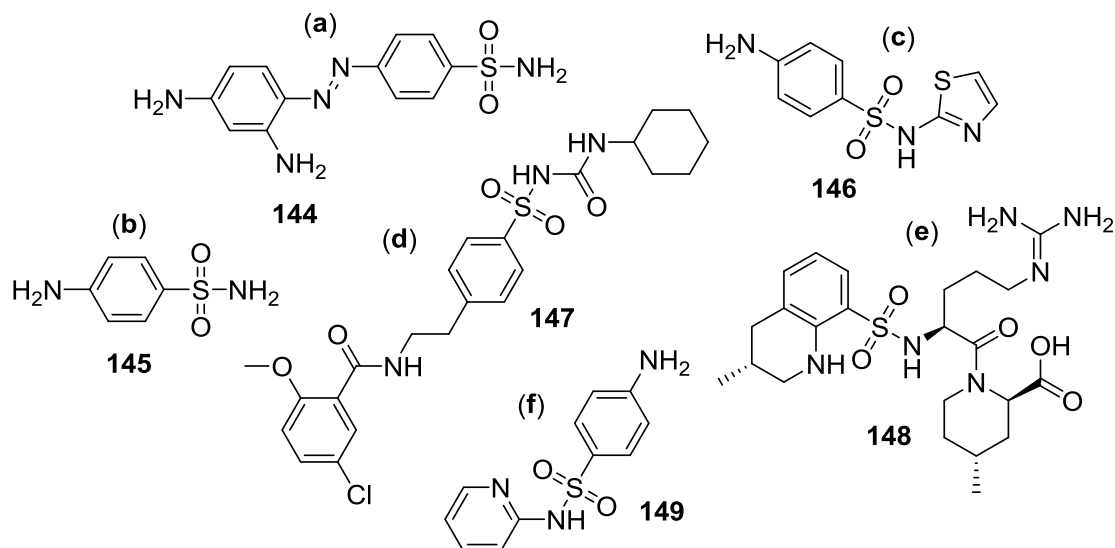

Figure (27): Examples of biologically active compounds containing the sulphonamide entity: (a) Prontosil; (b) sulphanilamide; (c) sulphathiazole; (d) glibenclamide; (e) argatroban and (f) sulphapyridine.

Heterocyclic compounds with one or more nitrogen atoms, especially those containing pyridine such as nicotinic acid derivatives, play important roles in biochemistry and biology.²⁰⁴⁻²¹² Moreover, sulphonamides derived from nitrogenous parent compounds are sometimes valuable in medicinal and pharmaceutical contexts.²¹³⁻²¹⁷ Thus Prontosil, **144**, which was originally developed as a diazo dye, became (one of) the first commercially available antibiotics.²¹⁸⁻²²¹ Prontosil breaks down in the body to *p*-aminobenzenesulphonamide (sulphanilamide)²²¹, **145**, a less complex sulphonamide. This finding led to the development of “sulpha-drugs”. Illustrative examples of sulfa-drugs²²² include sulphathiazole, **146**, (an

antibacterial agent),²²³ glibenclamide, **147**, (a hypoglycaemic agent),²²⁴ argatroban, **148** (an agent thrombin inhibitor)²²⁵ and sulphapyridine, **149**, (which was used in treatment of pneumonia,^{226, 227} see Figure (27) above.

8.2. Background

8.1.1. The Chan Rearrangement

The base mediated isomerisation of α -acyloxyacetate esters is known as the Chan rearrangement. The α -acyloxyacetate ester was obtained by treating a halogeno ester with a carboxylic acid. Treatment of the archetypal α -acyloxyester **150** with LDA (2 eq.) at 0 °C, followed by quenching with dilute hydrochloric acid (HCl), gave the corresponding 2-hydroxy-3-ketoester, **151**. If the reaction was quenched with Ac₂O or TMSCl instead of HCl, other interesting compounds **152A** and **152B**, and **153** (via the intermediate, **154**),²²⁸ respectively, were obtained instead, Scheme (58).

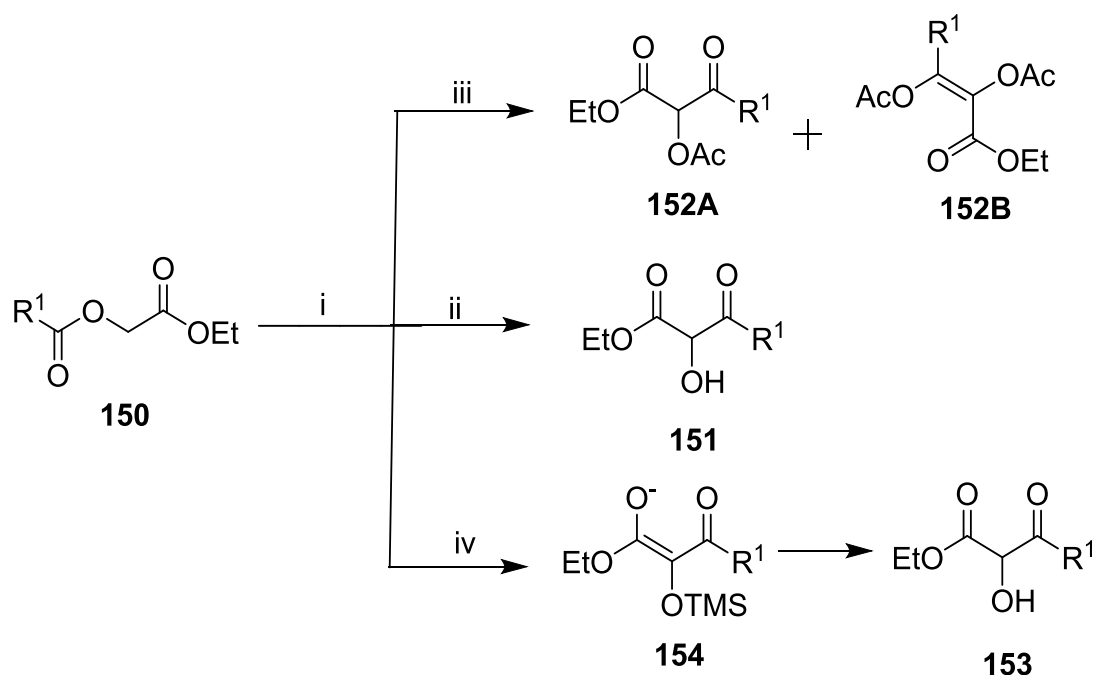

Scheme (58) Reagents and conditions: i) LDA, THF, 0 °C, 30 mins; ii) HCl (0.1 N); iii) Ac₂O; iv) TMSCl.

Subsequently, an analogous base-mediated rearrangement of imides to form α -aminoketones was reported. Thus, when **155** was treated with 3 equivalents of LDA in tetrahydrofuran (THF) in the presence of *N,N*-dimethylpropyleneurea (DMPU), the corresponding α -aminoketone, **156** was obtained,²²⁹ Scheme (59). The driving force for this reaction is the stability of the anion with the negative charge formally localised on nitrogen compared to that when the negative charge is located on carbon. This process may be considered to exemplify an “amino-Chan” rearrangement.

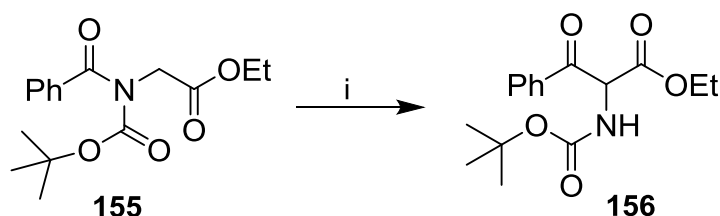

Scheme (59) *Reagents and conditions*: i) LDA, THF, DMPU, -78 °C, 91%.

This Chan methodology, in which a rearrangement is exploited to produce a skeleton that might otherwise be difficult to form, has been utilised in the synthesis of the indole-bisaxazole subunits of diazoamide A, **157**, (a cytotoxic marine metabolite).²³⁰ This approach has also found application in the first total synthesis of taxol, **158**,²³¹ which permitted a product to be prepared with a high diastereoselectivity, Figure (27).

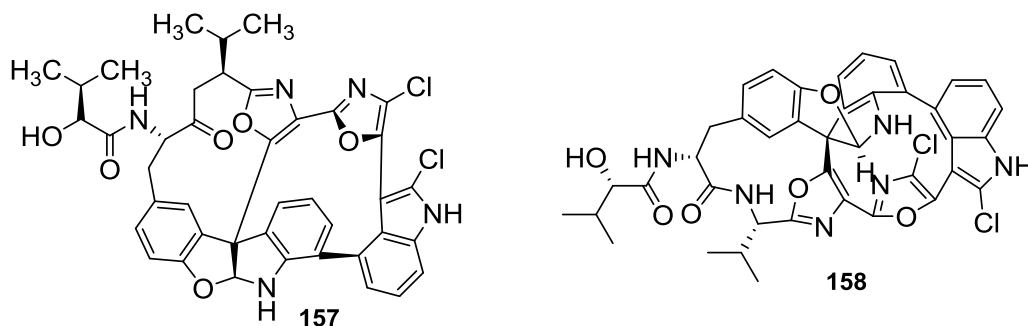
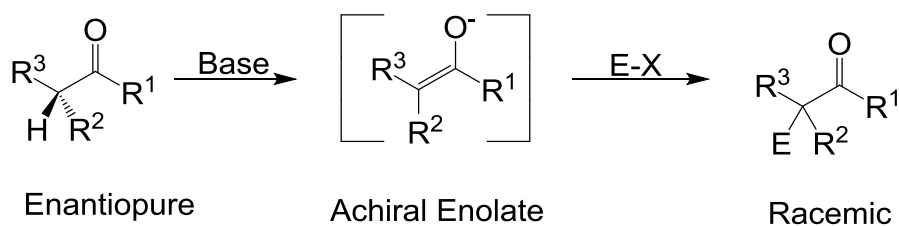

Figure (27): Examples of natural products synthesised by the chan method; a) Diazoamide; b) Taxol.

8.1.2. Asymmetric Alkylation of α -Amino Acids

Amino acids, which are the building blocks of proteins,²³²⁻²³⁴ make up a large portion of mammalian and human bodies.²³⁵⁻²³⁸ One function of amino acids is to assist in the transport and storage of nutrients. As mentioned in Chapter 1.1.2.2, tryptophan, **4**, is an example of an essential amino acid that contains the indole nucleus. Apart from glycine, which is not chiral, all natural amino acids exist as the *L*-stereoisomer. The extensive interest in finding effective methods for synthesising amino acids, preferably in one enantiomeric form, reflects their biological importance. The most common and efficient general method is via enolate chemistry using a chiral source²³⁹. However, when a single enantiomer of a reagent reacts with a base in the absence of a chiral source (an electrophile, ligand or auxiliary), the reaction leads to a racemic mixture.^{229, 240} This loss of stereochemical integrity occurs because the intermediate enolate is achiral (all four substituents, R^1 , R^2 , R^3 and S, are in the same plane), Scheme (60).



Scheme (60): Reaction of a single enantiomer of a precursor carbonyl compound via the corresponding achiral enolate in the absence of a chiral source.

However, it has recently been discovered that on a specific timescale reactions of this kind involving an enolate do not always lead to loss of the original stereochemistry. If the enolate possesses an appropriate symmetry element, particularly axial chirality, at least some of the stereochemical information in a single enantiomer of the starting material can be

preserved.^{229, 241-243} This concept suggests that the reaction of a suitable enolate need not necessarily result in the formation of a racemic product, even when it is done in a non chiral environment. This idea is known as Memory of Chirality (MoC).^{229, 239, 244, 245} The requirement for MoC has recently been shown to include three criteria: firstly, a chiral enolate intermediate must be formed from a single enantiomer of the starting material; secondly, racemisation of the chiral intermediate must take place at a slow rate; and, thirdly, the conversion of the chiral intermediate must occur at an enhanced rate. If all three criteria are met, it is possible to make use of enolate chemistry without losing the stereochemical properties of the starting material, even in achiral environments.²⁴⁶

Although the idea of axial chirality appears at first sight to contradict the normal understanding of the structure and reactivity of enolates, which are generally considered to be planar species,²⁴⁷ it has been recognised for many decades that compounds may be optically active even if they do not possess a chiral centre. For example, certain allenes²⁴⁸⁻²⁵⁰ and spirocompounds^{251, 252} exist in two enantiomeric forms, as do biaryl compounds in which rotation about the C-C bond connecting the aryl groups is restricted because it entails unfavourable steric interactions between ortho substituents.^{240, 253-255} Similarly, the two forms of fused polyaromatic hydrocarbons such as hexahelicene^{256, 257} and heptahelicene^{258, 259} show very high specific rotations, even though there is no chiral centre in the molecule.²⁶⁰⁻²⁶⁴ All these classes of compounds can be considered to illustrate the principle of axial chirality. These species show stereoisomerism because chirality is a molecular property, arising because the two

enantiomeric forms are not superimposable. A parallel argument indicates that the transition state involved in elaboration of an apparently achiral enolate may also have axial chirality, provided that the time taken for the elaboration (in this case, an alkylation) is substantially shorter than that required for interconversion of the enantiomers (racemisation for enolates).

It is important to appreciate that the conservation of stereochemical information depends on the timescale of the competing processes (elaboration versus racemisation for enolates) as well as temperature at which the elaboration is performed. The concept of asymmetric induction was demonstrated by the treatment of the phenylalanine derivative, **159**, with potassium hexamethyldisilazide (KHMDs) at $-78\text{ }^{\circ}\text{C}$ in toluene/THF (4:1), followed by quenching with methyl iodide (MeI), Scheme (61). The reaction resulted in the formation of the methylated product, **160**, in 96 % yield with an enantiomeric excess of 81%.²³⁹ This reaction retains stereochemical information because the intermediate enolate has a dynamic axial chirality²²⁹ along the C-N bond with different groups around the nitrogen atom. Moreover, the corresponding α -methylated phenylalanine derivatives with aromatic and aliphatic substituents were also obtained in a good yield with high enantiomeric excess.

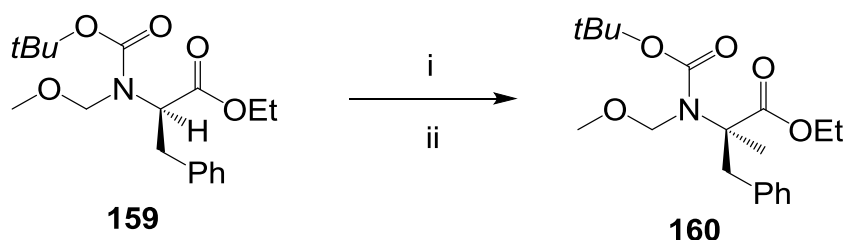

Scheme (61) *Reaction and Conditions*: i) KHMDs, toluene/THF, $-78\text{ }^{\circ}\text{C}$, 30 mins; ii) MeI, 96%.

8.2. Aim

In the context of this research, the principal original aim was to synthesise novel amino acids by combining the amino-Chan rearrangement with asymmetric alkylation methodology. The amino-Chan method would be used to attempt to transfer acyl groups or other substituents from nitrogen to carbon; amino acid derivatives be alkylated, ideally exploiting axial chirality to prepare unusual amino acids, preferably in high enantiomeric excess.

8.3. Results and Discussion

The starting point in the series of experiments designed to combine the idea of incorporating rearrangements with the synthesis of amino acids, was the *tert*-butoxycarbonylation of glycine ethyl ester, **161**, with di-*tert*-butyl dicarbonate to give the Boc protected glycine ethyl ester derivative, **162**. This initial step took place in good yield. Aryl amination of **162** with 4-bromopyridine or 2-bromopyrimidine in the presence of palladium(II)acetate [Pd(OAc)₂], xantphos and caesium carbonate (Cs₂CO₃) afforded **163** and **164** respectively, Scheme (62). Although these archetypal derivatives of π -deficient heterocycles were successfully prepared, they did not undergo the anticipated rearrangement when treated with LDA, Thin Layer Chromatography (TLC) showed that no reaction took place.

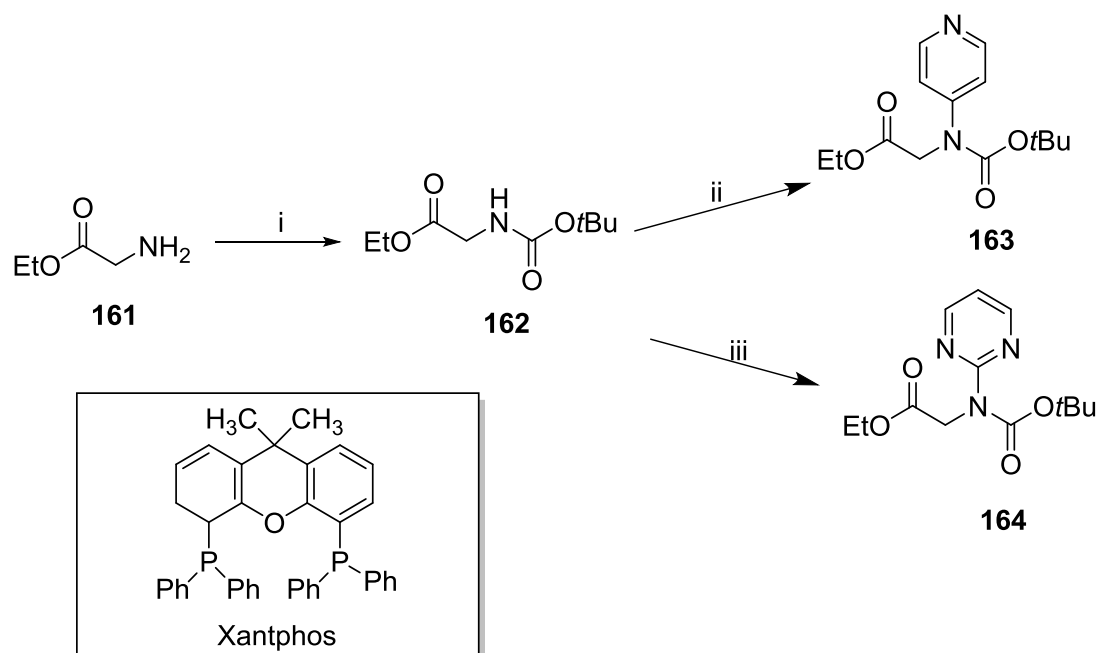

Scheme (62) *Reagents and conditions:* i) Boc_2O , DMAP, CH_2Cl_2 , 90%, ii) 4-bromopyridine, $\text{Pd}(\text{OAc})_2$, xantphos, Cs_2CO_3 , 60%; iii) 2-bromo-pyrimidine, $\text{Pd}(\text{OAc})_2$, xantphos, Cs_2CO_3 , 65%.

In response to this negative result, the substrate that was to be subjected to the rearrangement was carefully reconsidered. It was thought that the rearrangement might be promoted if an electron withdrawing substituent was attached to the nitrogen atom, effectively functioning as a “protecting group” that would confer specific electronic properties on the substrate. These deliberations led to the idea of attempting the amino-Chan rearrangement on carbamates derived from pyridine sulphonamides, in which the two groups on nitrogen might help to establish axial chirality along the C-N bond, which might in turn permit unnatural and novel amino acids and their derivatives to be synthesised, Scheme (63).

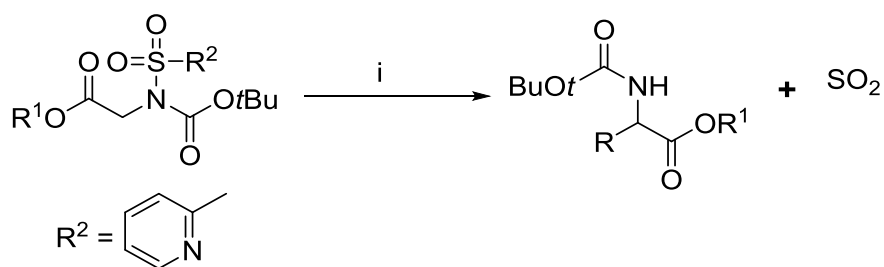

Scheme (63) Reaction and conditions: i) LDA, THF, -78 °C, N₂.

The revised synthetic sequence involved treating 2-mercaptopyridine, **165**, with sodium hypochlorite and hydrochloric acid to give 2-pyridinesulphonylchloride, **166**. This acid chloride is air sensitive; therefore, the crude material was not isolated, but was instead reacted directly with the *tert*-butyl ester of valine. The resultant sulfonamide, **167**, was Boc protected in the standard way to afford the corresponding carbamate, **168**, which was obtained in excellent yield. This protected species was then treated with LDA at -78 °C in the hope of deprotonating and alkylating of the derived anion with MeI to give **169**, Scheme (60).

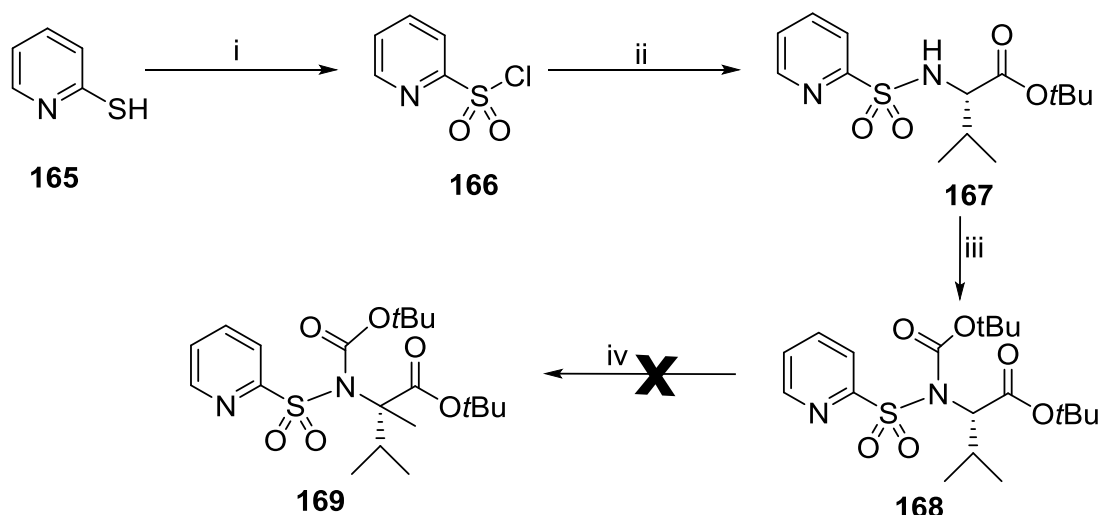

Scheme (64) Reagents and conditions: i) HCl, NaOCl, CH₂Cl₂, 58%; ii) *tert*-butyl ester of valine, Et₃N, CH₂Cl₂, 87%; iii) Boc₂O, DMAP, CH₂Cl₂, 86%; iv) LDA, THF, -78 °C, N₂, 90%.

However, TLC obtained 2 minutes after the LDA was added showed a new spot, before any MeI was added. This new material had a lower R_f value than the starting material; consequently, it was more polar than **168**. Subsequent TLC analysis 5 mins afterwards showed that all the starting material had been consumed before any methyl iodide was added. This finding indicated that α -methylated amino acid derivative, **169**, cannot be obtained by this proposed method, Scheme (**64**), because a new and unexpected product was preferentially formed. The unexpected product was investigated by spectroscopic analysis (IR, 1D NMR, 2D NMR and mass spectrometry) in order to establish its structure. The FT-IR spectrum was dominated by strong bands at 1727 cm^{-1} , corresponding to a C=O stretching vibration (typical of a conjugated ester or carbamate), and 1307 and 1138 cm^{-1} , arising from the asymmetric and symmetric S=O stretching vibrations (typical of a conjugated sulfonamide). In addition, the spectrum also showed a band of medium intensity at 3200 cm^{-1} (typical of the N-H or an amide or sulphonamide), which was not present in the spectrum of the starting material, **168**. The 8.57 - 7.42 ppm region of the ^1H NMR spectrum contained 3 doublets of doublets signals, which integrated for 1 proton each, thus revealing the presence of only three aromatic protons on adjacent positions in the heterocyclic ring. A comparison of the ^1H NMR spectrum of the starting material with that of the unexpected product showed that the signal for the proton in the 3 position of **168** had disappeared. The spectrum of the unexpected product also showed a broad signal at 5.98 ppm, which was assigned to N-H which was not present in the spectrum of **168**. The aliphatic

region showed a singlet peak at 1.22 ppm, which integrated for 9 hydrogens, and which was assigned to the *t*-butyl group, Figure (29).

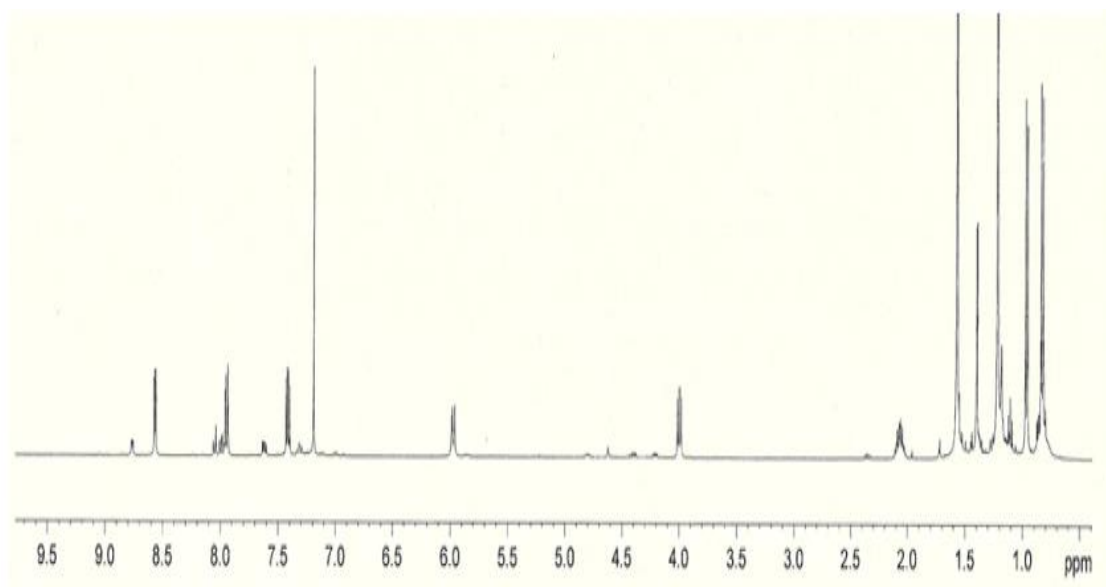
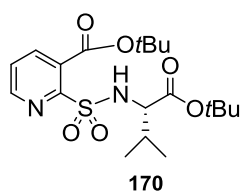
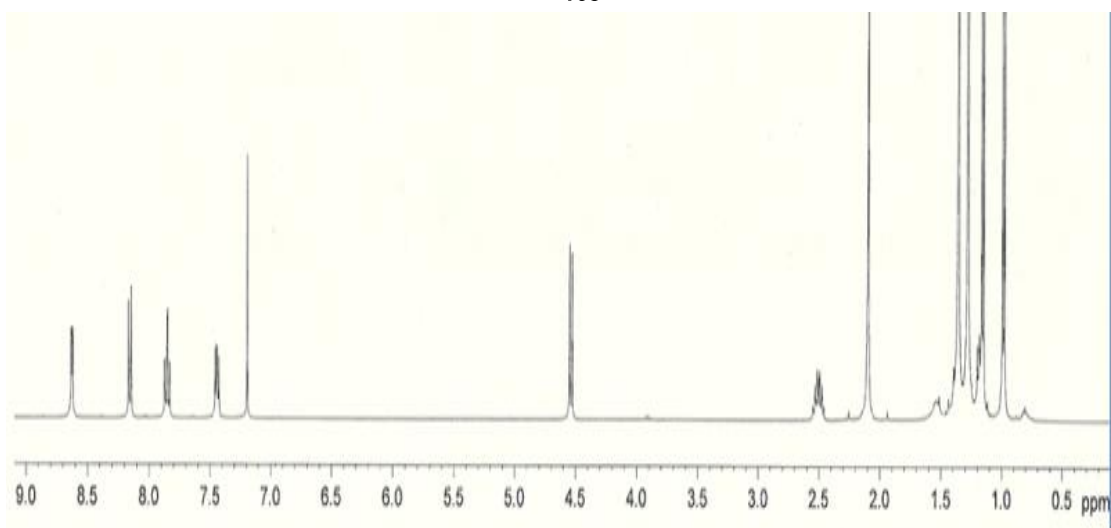
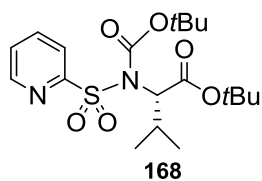
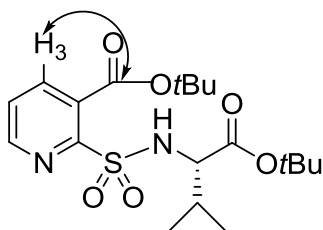

Figure (29): ¹H NMR spectra (CDCl₃; 400 MHz); top: starting *N*-acylated derivative; bottom: rearranged product, **170**.

The Heteronuclear Multiple Bond Correlation (HMBC) spectrum showed a correlation between the carbon atom of the carbonyl atom of ester group and H-4 of the pyridine ring, Figure (30), thus establishing that the carbon atom of the carbonyl group lies in close proximity to the hydrogen atom attached to the carbon atom in position 4 of the pyridine ring.



170

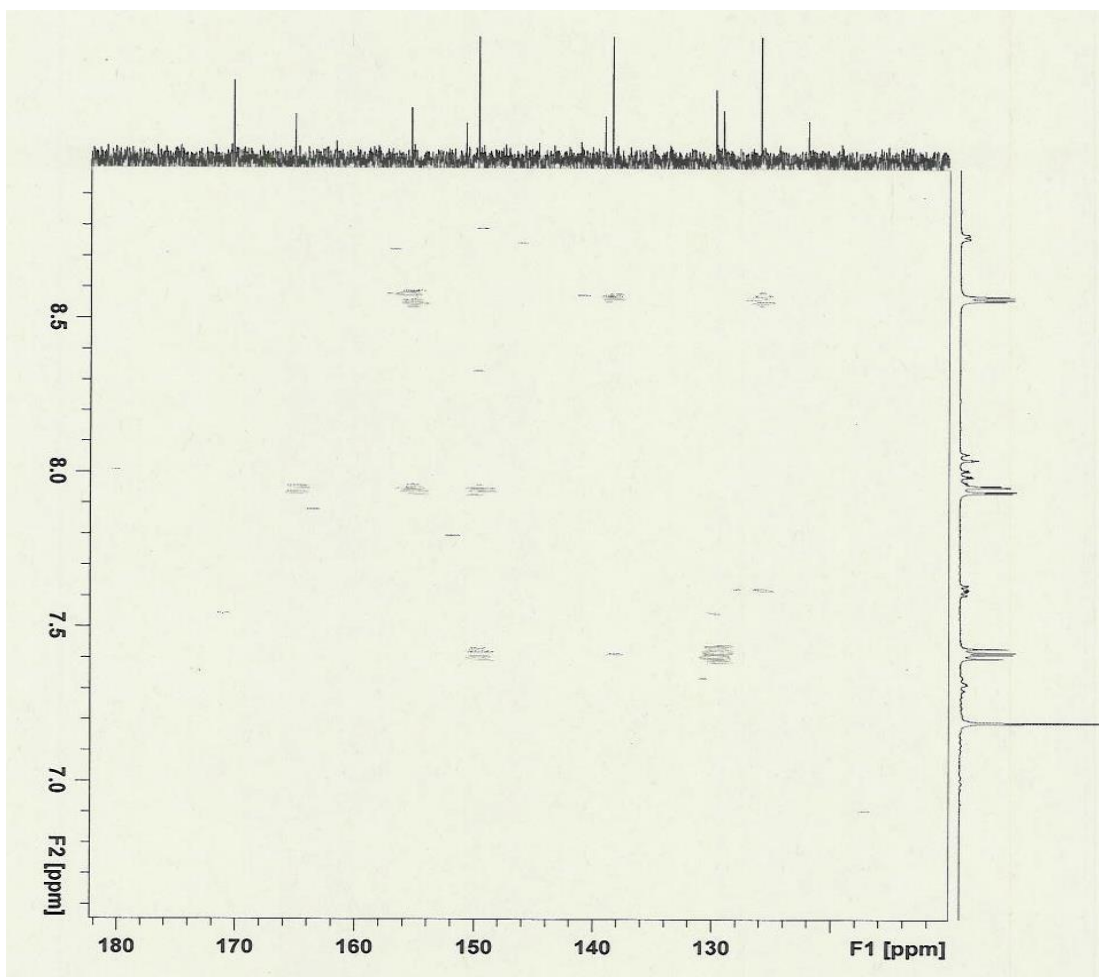
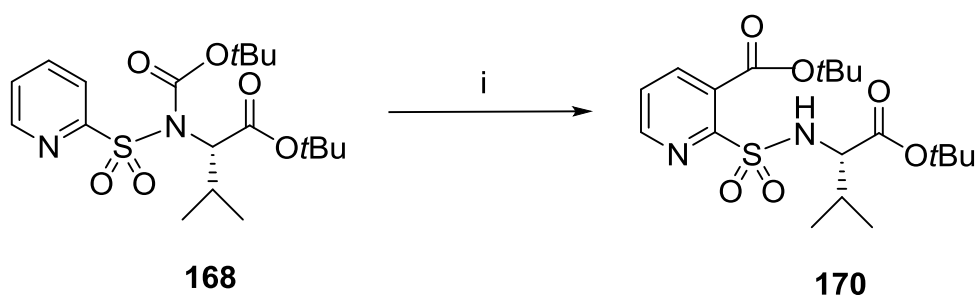

Figure (30): HMBC spectrum of the unexpected product, 170.

The ESI+ spectrum of the unexpected compound contained a peak at m/z 415, corresponding to MH^+ . This result confirmed that the unexpected product has the same relative molecular mass the starting material, **168**. Furthermore, accurate mass measurements at high resolution under ESI+ conditions confirmed that both compounds have the same molecular formula ($C_{12}H_{30}N_2O_6S$). Based on these spectroscopic data, it was concluded that the desired asymmetric methylation of *N*-tert-butyl carbamate, **168**, had been pre-empted by an isomerisation, in which the carbonyl group on nitrogen had migrated to the 3 position of the pyridine ring, thus forming the ester, **170**, Scheme (65).



Scheme (65) *Reagents and conditions:* i) LDA, THF, -78 °C, N_2 , 90%.

8.3.1. The Mechanism of the Rearrangement

This base mediated rearrangement presumably begins with deprotonation of the pyridine ring, followed by intramolecular attack of the resultant anion on the carbonyl carbon atom of the carbamate. It is interesting that only one regioisomer is formed, corresponding to formation of the initial anion on the 3-position of the pyridine ring. Furthermore, the fact that a simple pyridine ring cannot be deprotonated by LDA suggests that the mechanism for the formation of the anion possibly involves directed ortho metallation. Two postulates may be made on the basis of these observations,

namely that the deprotonation step and/or the stabilisation of the intermediate anion, **171**, (or transition state) is facilitated by coordination of the lithium counterion with either the sulphonamide or the carbamate, which involves a 5- or 7-membered ring, **172** or **173**, respectively, Scheme (66).

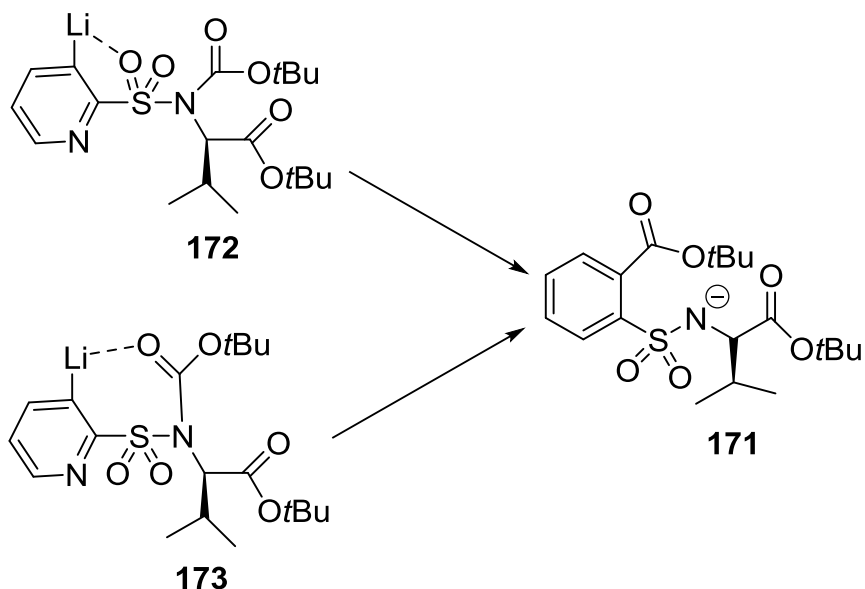

Scheme (66): Stabilisation of the intermediate anion by co-ordination of the lithium cation with the sulphonamide, **172**, or the carbamate, **173**.

8.3.2. The Scope of the Reaction

8.2.2.1. Synthesis of Nicotonic Acid Sulphonamides

To investigate the generality of this synthetic route, a range of *N*-substituted pyridine sulfonamides were synthesised, Scheme (67).

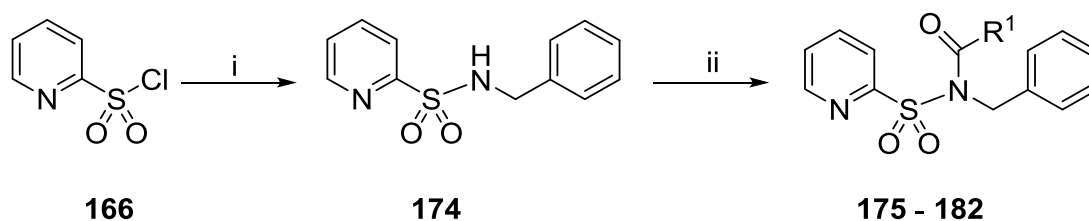

Scheme (67) *Reagents and conditions*: i) PhCH_2NH_2 , Et_3N , CH_2Cl_2 , 98%; ii) NaH , THF , R^1COCl , 0 °C to rt or $\text{R}^1\text{CO}_2\text{COR}^1$, DMAP, py .

Table (21): Formation of *N*-acyl sulphonamides.

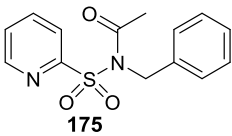
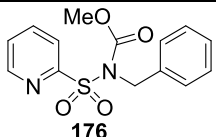
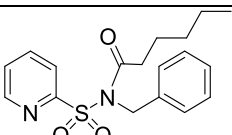
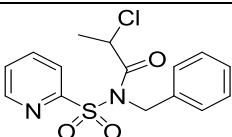
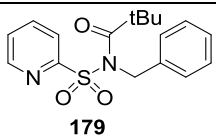
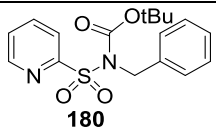
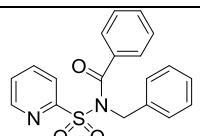
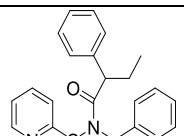
Entry	R ¹	Product	Yield (%)
1	Me	 175	95
2	MeO	 176	99
3	<i>n</i> C ₅ H ₁₁	 177	82
4	(CH ₃)CHCl	 178	78
5	<i>t</i> Bu	 179	75
6	<i>t</i> BuO	 180	95
7	Ph	 181	81
8	(CH ₃ CH ₂)CHPh	 182	77

A suitable parent sulphonamide was readily prepared by treating benzylamine (chosen as a representative primary amine) with pyridine sulphonyl chloride, **166**, in dichloromethane solution in the presence of triethylamine (which acts as a catalyst and acid scavenger). When this sulphonamide, **174**, was treated with sodium hydride, followed by an acyl chloride, anhydride, chloroformate or carbonate, the corresponding *N*-substituted pyridine sulfonamides, **175-182** were isolated in good to excellent yield, see Table (21) above.

Having prepared a range of carbamates ($R^1 =$ alkoxy or aryloxy) and amides ($R =$ alkyl or aryl), the rearrangement was attempted by reacting the substrate with 1.5 equivalents of LDA at $-78\text{ }^\circ\text{C}$ in THF. In most cases, TLC obtained 5 minutes after the addition of the LDA showed new spots and the disappearance of all the starting material. When the reactions were worked up by quenching with citric acid solution, followed by extraction of the organic material with CH_2Cl_2 , the corresponding nicotinic acid sulfonamides, **183-189**, were obtained in good to excellent yield, see Scheme (68) and Table (22). However, the *N*-acetyl, entry **1** in Table (21); did not give the desired nicotinic acid. The acetyl derivative gave a mixture of products, possibly because the ease of deprotonating the methyl group of the acetyl substituent pre-empts the rearrangement.

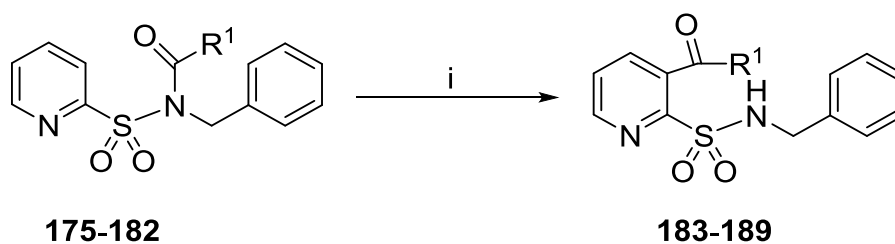

Scheme (68): Reagents and conditions: i) LDA, THF, $-78\text{ }^\circ\text{C}$, N_2 , 76-96%.

Table (22): Synthesis of nicotinic acid sulfonamides

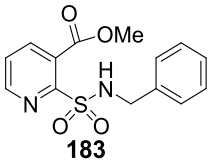
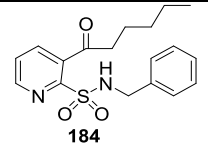
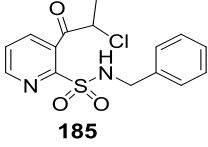
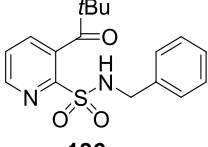
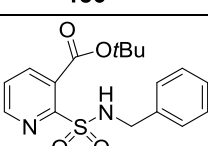
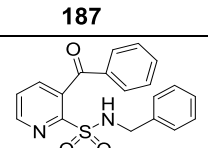
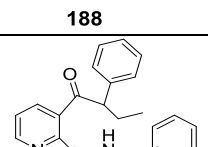
Entry	Substrate	Product	Yield ^a
1	176	 183	82
3	177	 184	96
4	178	 185	76
5	179	 186	88
6	180	 187	86
7	181	 188	78
9	182	 189	90

8.3.2.2. Formation of Isopropyl Sulphonamide Derivatives

Since this unexpected rearrangement had been successfully applied to synthesise a library of nicotinic acid sulphonamides, it was decided to explore the potential of this methodology by investigating whether it occurred in systems with other aryl groups that might undergo directed ortho

metallation. The obvious series of compounds to study contained a *paratoluenesulphonyl* group, which is commonly employed to protect amines.

The first step in this part of the investigation was to prepare a suitable carbamate derived from a representative sulphonamide. Treatment of valine *t*-butyl ester, **191** (itself accessible by reacting valine with *t*-butyl acetate), with *p*-toluenesulphonyl chloride, **190**, in the presence of triethylamine, gave the representative sulphonamide, **192**, containing an amino acid. This sulphonamide was “Boc” protected under standard conditions to give the carbamate, **194**, which was treated with LDA in THF at -78 °C in the usual way, Scheme (69).

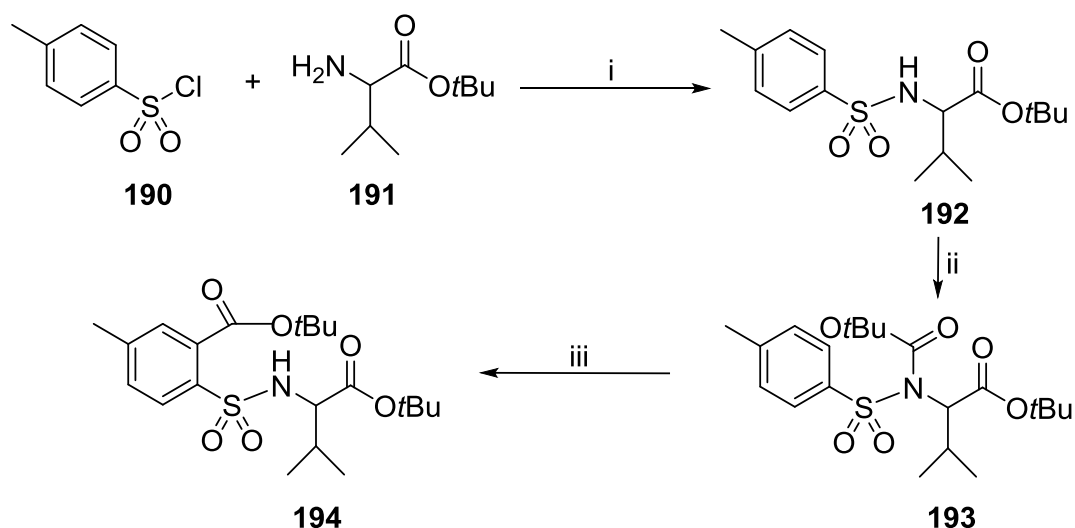

Scheme (65) *Reagents and condition*; i) *t*-butyl ester of valine, Et₃N, CH₂Cl₂, 95%; ii) Boc₂O, DMAP, CH₂Cl₂, 78%; iv) LDA, THF, -78 °C.

When the reaction was monitored by TLC, it was observed that all the starting material has been consumed 10 mins after the LDA had been added. Consequently, the reaction was worked up in the standard manner and the product obtained was analysed. The FT-IR spectrum contained a band of medium intensity at 3292 cm⁻¹ and a strong band at 1714 cm⁻¹; these bands were attributed to the N-H stretch (of a secondary sulphonamide) and the

C=O stretch (of an aromatic or conjugated ester). In addition, strong bands that were assigned to the asymmetric and symmetric S=O stretches of the sulphonamide group were observed at 1256 and 1137 cm^{-1} , respectively. The ^1H NMR spectrum showed one singlet and two doublet peaks in the region between 7-8 ppm, each integrating for a single proton, corresponding to a total of three aromatic protons. The singlet at 7.49 ppm was assigned to the proton between the methyl group and the carbonyl group. This signal is the only peak for a proton ortho the carbonyl group. As had been observed in the HMBC spectrum of compound **171**, the analogous spectrum of **194** showed a correlation between the carbon atom of the ester and the isolated proton on the benzene ring next to the methyl group. Further analysis by mass spectrometry under ESI+ conditions, including accurate mass measurements at high resolution, revealed that **194** had the same molecular mass and molecular formula as **193**. These spectral data established unequivocally that *tert*-butyl and 3-methyl-2-(4-methylphenylsulphonamido)butanoate, **193** rearranged to **194** in the same manner as **168** isomerised to **170**.

In view of this success, a range of orthogonally protected isopropyl amines were synthesised to explore the scope of this base mediated N-C rearrangement. Isopropylamine was chosen as the parent amine for two reasons: firstly, the parent sulphonamides were expected to be crystalline solids in most cases; secondly, it was anticipated that the isopropyl group would give rise to characteristic signals (a doublet integrating for six protons and a septet integrating for one proton) in the ^1H NMR, thus facilitating spectroscopic analysis. The required sulphonamides were synthesised by

reacting isopropylamine, **195**, with various sulphonyl chlorides, **196-199**. The corresponding sulphonamides, **200-203** were treated with boc anhydride, and methyl and ethyl chloroformates, to give the desired carbamates, in good yield, Scheme (70) and Table (23). Varying the nature of the substituent, X, in the 4-X-C₆H₄SO₂Cl sulphonyl chlorides allowed the influence of X on the rearrangement to be explored: when X = H, the electron density distribution in the aromatic ring in the sulphonamide would not be perturbed by the substituent; in contrast if X = CH₃ (slightly electron donating), CH₃O (strongly electron donating) or NO₂ (strongly electron withdrawing), significant effects on the electron density distribution (and, perhaps, on the viability of the rearrangement) would be expected.

Table (23): Formation of the parent sulphonamides

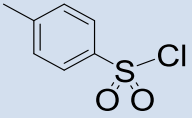
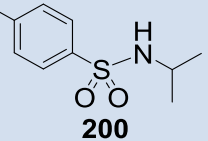
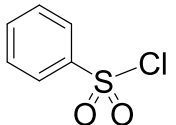
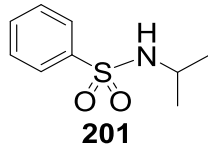
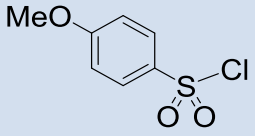
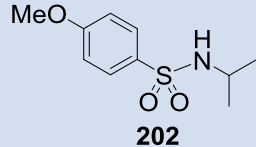
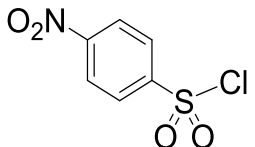
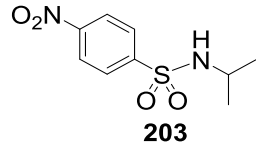
Entry	Sulphonyl Chloride	Sulphonamide	Yield (%)
1			92
2			95
3			91
4			84

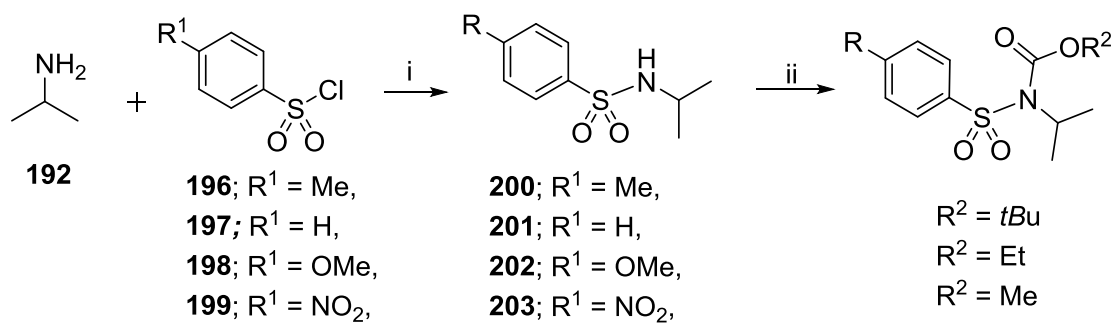

Scheme (70) Reagents and condition; i) Et₃N, CH₂Cl₂, 98%; ii) NaH, THF, R¹COCl, 0 °C to rt or R¹CO₂COR¹, DMAP, py.

Table (24): Synthesis of the carbamates

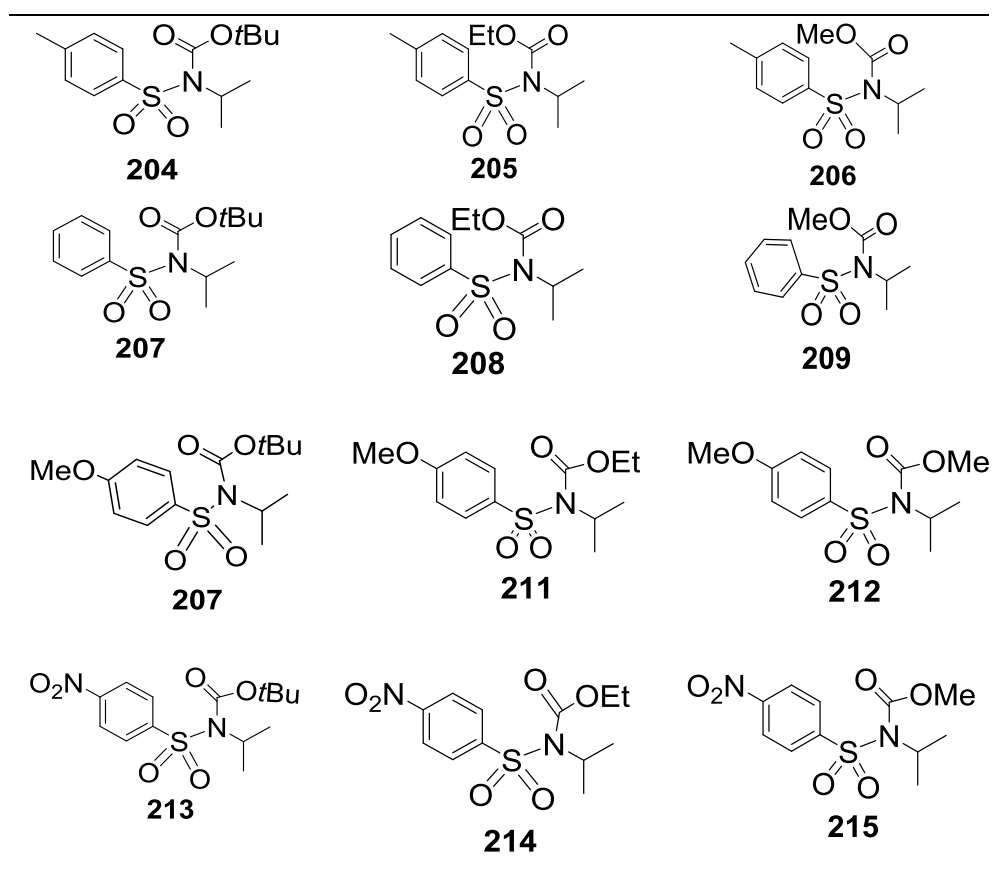

In order to determine whether the migration of a carboalkoxy (CO₂R¹) group from the nitrogen to carbon is general, regardless of the nature of the substituent, R, in the aryl ring of the sulphonamide, the members of the series of carbamates, **204-215**, were treated with LDA under the standard

conditions to investigate whether migration would occur, Scheme (71) and Table (25). When R = Me, H and MeO, **204-212**, the acyloxy group migrated from the nitrogen to the carbon to give the corresponding 2-carboalkoxysulphonamide in excellent yield within 10 mins, entries (1-9) in Table (25). In contrast, when the corresponding nosyl derivatives (R = NO₂) were subjected to the same treatment with LDA, no transfer of the carboalkoxy group to the aromatic ring took place. The *N*-protected nosyl sulphonamides were recovered unchanged, entries (10-12) in Table (25).

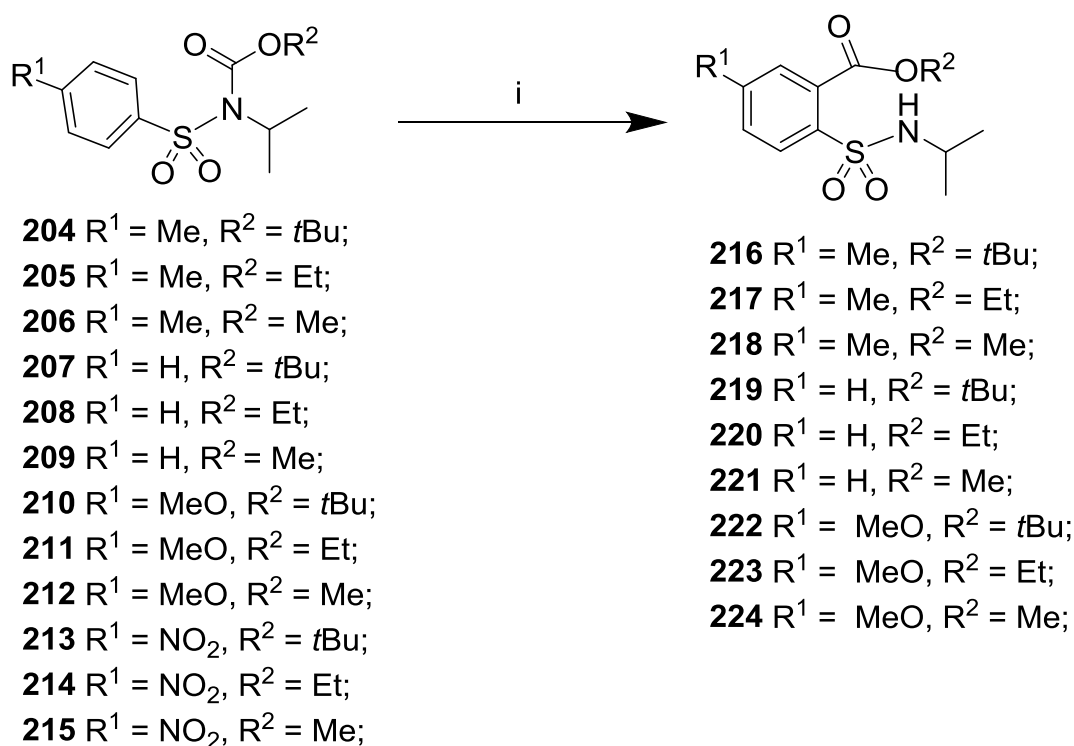

Scheme (71) *Reagents and conditions*: i) LDA, THF, -78 °C, N₂.

When LDA was added to the solution of the carbamates derived from these *p*-nitrosulphonamides, a deep yellow colour developed in the reaction mixture. This colour change is often associated with deprotonation of a substrate to form an anion. The failure of the acyloxy groups on the *p*-nitrosulphonamides to migrate to the aromatic ring was, therefore, initially

attributed to stabilisation of the anion formed after the deprotonation of the benzene ring to such an extent that no nucleophilic attack occurred on the carbonyl carbon atom of the carbamate. Unfortunately, however, attempts to verify this postulate by quenching the reaction mixture with D₂O, in the hope of producing a monodeuterio analogue of the carbamate, which would have had distinctive ¹H NMR and mass spectra, were not successful.

Table (25): Effect of structural features on the rearrangement.

Entry	R	R'	Rearranged Product	Yield (%)
1	Me	<i>t</i> Bu	216	85
2	Me	Et	217	78
3	Me	Me	218	83
4	H	<i>t</i> Bu	219	92
5	H	Et	220	78
6	H	Me	221	84
7	MeO	<i>t</i> Bu	222	90
8	MeO	Et	223	93
9	MeO	Me	224	80
10	NO ₂	<i>t</i> Bu	-	No reaction
11	NO ₂	Et	-	No reaction
12	NO ₂	Me	-	No reaction

8.3.2.3. Formation of Sulphonamides Derivatives from *Tert*-butyl Aniline

A further extension of this work was effected by the successful synthesis of a range of sulphonamides derived from *p*-*t*-butylaniline, **225**. In this series, the substituent [$R^1 = \text{Me}, \text{CF}_3, \text{CH}_3\text{CO}, \text{MeO}, \text{F}, \text{Cl}, \text{Br}$ and CN] at the 4-position of the sulphonyl chloride was varied more extensively. These sulphonyl chlorides were treated with *tert*-butylaniline to give the corresponding sulphonamides, typically in excellent yield, Scheme (72, step i) and Table (26).

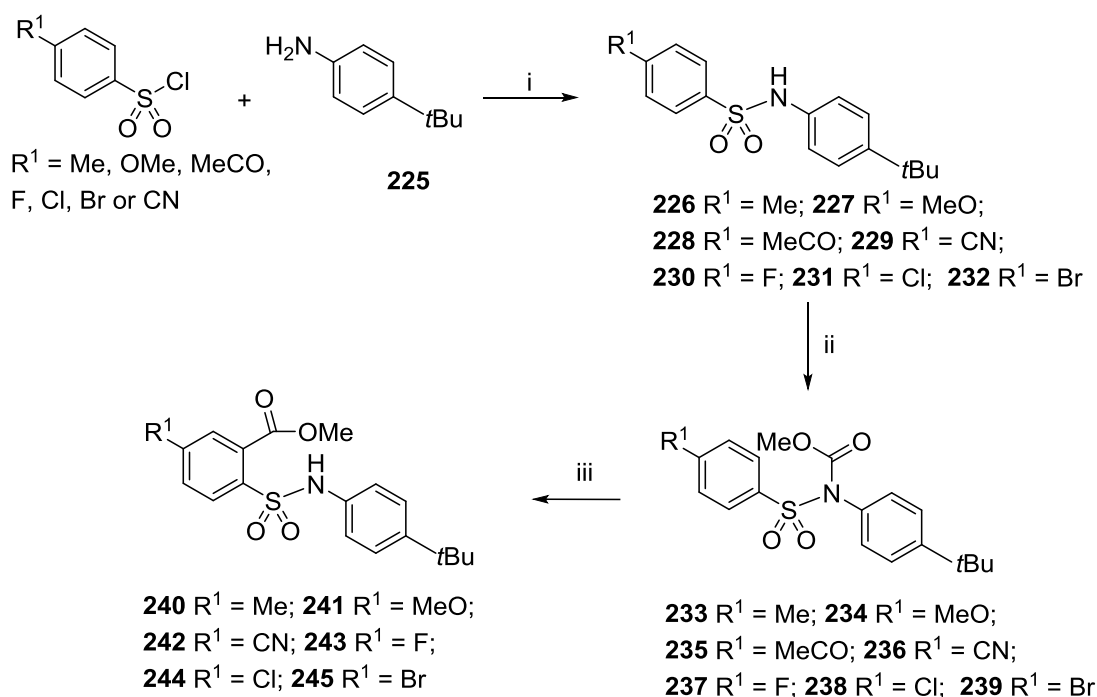

Scheme (72) *Reagents and conditions:* i) Et_3N , CH_2Cl_2 , 87%; ii) MeOCOCl , THF, NaH iii) LDA (3 equ.), THF, -78°C , N_2 .

Table (26): Formation of sulphonamide derived from *tert*butyl aniline.

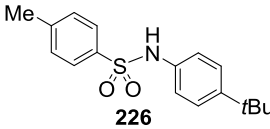
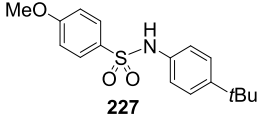
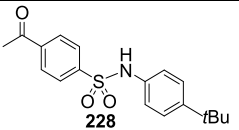
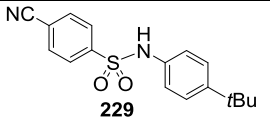
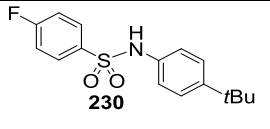
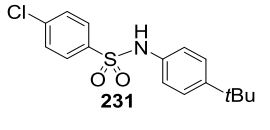
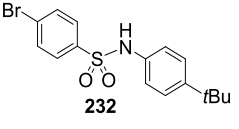
Entry	Sulfonyl chloride	Sulphonamide	Yield (%)
1	4-MeC ₆ H ₄ SO ₂ Cl	 226	84
2	4-MeOC ₆ H ₄ SO ₂ Cl	 227	53
3	4-MeCOC ₆ H ₄ SO ₂ Cl	 228	92
4	4-NCC ₆ H ₄ SO ₂ Cl	 229	88
5	4-FC ₆ H ₄ SO ₂ Cl	 230	93
6	4-ClC ₆ H ₄ SO ₂ Cl	 231	91
7	4-BrC ₆ H ₄ SO ₂ Cl	 232	81

Elaboration of the sulphonamides, **226-232**, by treatment with methyl chloroformate (MeOCOCI) in THF in the presence of NaH, gave the corresponding *N*-carbomethoxysulphonamides, **233-239**, in yields that varied from fair to excellent, Scheme (72, step ii) and Table (27). Any influence of the nature of R of the efficiency of the transfer of the carbomethoxyl group from nitrogen to carbon could them be probed.

Table (27): Formation of carbamates of sulphonamides derived from *tert* butyl aniline.

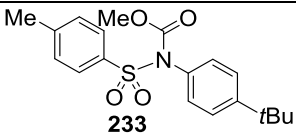
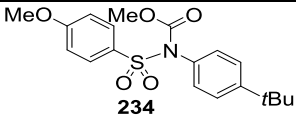
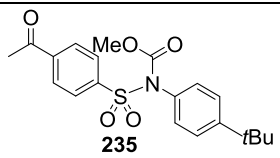
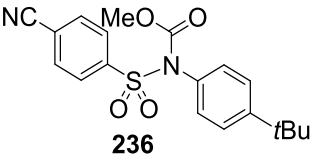
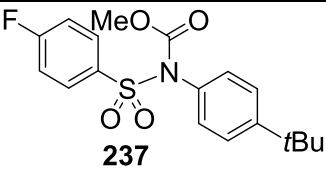
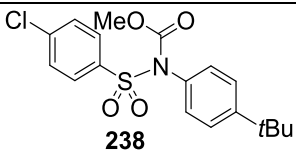
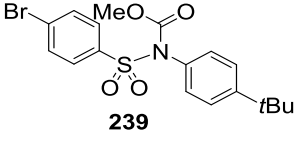
Entry	Sulphonamide	Carbamate	Yield (%) ^a
1	226	 233	96
2	227	 234	93
3	228	 235	44
4	229	 236	41
5	230	 237	93
6	231	 238	36
7	232	 239	76

The initial attempt to induce base-mediated rearrangement was made on **233** with 1.5 equivalents of LDA and a reaction time of 10 minutes. Analysis

of the reaction mixture by TLC after 20 minutes revealed no new spot; consequently, it was concluded that no reaction had taken place. Nevertheless, the reaction was worked up by quenching with aqueous citric acid solution, followed by extraction with DCM. Spectroscopic analysis of the material that was isolated by ^1H NMR revealed the presence of residual starting material, apparently confirming the conclusions reached on the basis of the TLC monitoring of the reaction; however, the spectrum also showed that at least one new compound had been formed. Consideration of the FT-IR spectrum, which showed a band at 3200 cm^{-1} that was attributable to an N-H stretching vibration, led to similar conclusions: it appeared that the N-carboalkoxy group had been removed, possibly because the rearrangement had occurred after all. On the basis of the ^1H NMR and IR spectra, and the chromatographic results, two conclusions were drawn: firstly, the rearrangement had taken place to some extent, but had not gone to completion; and, secondly that the *N*-carbomethoxysulphonamide and the desired rearrangement product had closely similar R_f s.

Unfortunately, the closely similar chromatographic properties of the *N*-carbomethoxysulphonamides and the isomerised product means that the reaction cannot be monitored by TLC. In order to improve the reaction conditions, twice the quantity of LDA was used (4 instead of 1.5 equivalents). The ^1H NMR spectrum of the reaction mixture quenched 10 minutes after the addition of this increased quantity of LDA showed that no trace of the starting material remained and that the rearrangement had gone to completion.

When these improved conditions were applied to the other members of the series of *N*-carbomethoxysulphonamides, **224-239**, the desired

isomerised product was usually obtained in good yield, Scheme (72, iii) and Table (28). However for R¹ = CH₃CO (entry 4), the rearranged product was not obtained; instead, a mixture of products resulted, possibly because of the ease of deprotonation of the methyl group of the acetyl substituent in the 4-position of the aromatic ring. Any such deprotonation would compete with, or pre-empt entirely, the rearrangement. Nevertheless, despite this restriction, the rearrangement can be induced when the sulphonamide entity contains a range of substituents (electron attracting, as in R¹ = F, Cl, Br and CN, or electron donating, as exemplified when R¹ = Me and MeO).

Table (28): Rearrangements of carbamates derived from *t*-butyl aniline.

Entry	Substrate	R ¹	Rearranged Product	Yield (%) ^a
1	233	Me	240	78
2	234	MeO	241	95
3	235	MeCO	-	82 ^b
4	236	CN	242	77
5	237	F	243	98
6	238	Cl	244	73
7	239	Br	245	75

8.4. Conclusion

In summary, the base-mediated nitrogen to carbon rearrangement discovered in this research has clear synthetic potential. It gives access to a

series of nicotinic acid and sulphonamide derivatives (including sulphonamides derived from *t*-butylaniline), usually in good to excellent yield, in a short synthetic sequence comprising only three steps. The process can be effected for a range of *N*-carboalkoxysulphonamides, with several substituents in the 4-position of the aromatic ring, including the commonly available cases of $R^1 = \text{H, CH}_3, \text{CH}_3\text{O, F, Cl, Br, NC and CF}_3$. Therefore, it offers a general means of accessing numerous 2,4-disubstituted sulphonamides in which an carboalkoxy group has been added to the nitrogen atom and then transferred to the 2-position of the product. Several of these substituted sulphonamides, particularly those derived from 4-*tert*-butylaniline, may have potential as anti-cancer agents.

The discovery that the *N*-carboalkoxysulphonamides ($R^2 = \textit{t}\text{BuO, EtO and MeO}$) derived from 4-nitrobenzenesulphonamide did not undergo the desired isomerisation restricts the generality of this route from the synthetic perspective. However, this apparent limitation is potentially advantageous in another context because it has been tacitly assumed until this rearrangement was uncovered that sulphonamides are inert to most common bases. Consequently, when amines and similar nitrogenous compounds are protected as sulphonamides in reaction sequences that involve treatment of an intermediate with LDA, it is essential to choose the correct derivative which will not undergo the rearrangement described in this chapter. In order to pre-empt carboalkoxy transfer to the aromatic ring, nitrobenzenesulphonyl chloride, rather than the traditional toluenesulphonyl chloride or the common alternatives, including benzenesulphonyl chloride, chlorobenzenesulphonyl

chloride, bromobenzenesulphonyl chloride and methoxybenzenesulphonyl chloride, should be used.

9. CONCLUSIONS AND SUGGESTIONS FOR FURTHER WORK

Several useful conclusions may be drawn from the work summarised in this thesis, which spans the spectrum from analytical chemistry and spectroscopy, through the synthetic potential of novel processes occurring in the nebuliser of a mass spectrometer, to interesting rearrangements that are relevant in the field of conventional synthesis, especially the application of protecting groups.

The starting point of the study of the spectroscopic properties of tricyclic indoles revealed that the distinction between ketoindoles and hydroxindolenines with the oxygen functional group in the 4 position of the third ring is less clear cut than might have been thought, particularly when the vibrational spectra of these materials are recorded in the solid state. Thus, the infrared spectra of these solids do not show the expected strong bands for stretching the N-H and C=O bonds that are typical of normal indoles and carbonyl compounds. Nevertheless, a more careful consideration of these spectra indicates that these heterocycles are best described as ketoindoles, admittedly of rather unusual structure. Similar remarks apply with less force to their isomers with the oxygen function in the 1 position of the third ring; the requisite vibrational spectra show less deviation from those expected for ketoindoles. In contrast, the other two isomers, with a carbonyl group in the 2 or 3 position, are clearly "normal" ketoindoles. The mass spectra of these compounds are also informative: the isomeric "ketoindoles" with the tetrahydrocarbazole skeleton are distinguishable on the basis of their electron ionisation or electrospray spectra. Certain fragmentations appear to be influenced by precisely the same mechanistic considerations that govern

the electrophilic substitution of indoles. The electrophile is preferentially attached to the 3-position because the carbocyclic aromatic ring is not disrupted in the intermediate arenium ion (or because the electron density distribution in the Highest Occupied Molecular Orbital is highest at that position), whereas attachment of the electrophile to the 2-position leads to an arenium ion in which both rings no longer possess a complete sextet of electrons. Ionised tricyclic indoles with a 6,5,6 ring pattern often eliminate an alkene containing the carbon atoms in positions 2 and 3 (and any methyl groups attached to either of these ring atoms). This fragmentation can be described in terms of a cycloreversion (or, more loosely in the older literature, as a retro-Diels-Alder reaction); however, there are reasons to believe that this process occurs with a low degree of concert, in which one ring bond is essentially completely broken before the other begins to break. Further work to describe the mechanism of these processes would entail extensive isotopic labelling, which would be a major undertaking.

Attempts to determine by means of labelled internal standards the threshold at which tricyclic indoles could be detected by electrospray mass spectrometry were thwarted by an unexpected novel dimerisation, which produced covalently bound $[2M-H]^+$ ions in indoles containing an alkyl group in the 3-position. This unusual process is mechanistically interesting and analytically useful in distinguishing 1- and 2-alkyl indoles (which do not show the dimerisation) from their 3-alkyl isomers (which do form $[2M-H]^+$ dimers). It appears that 3-methylindole dimerises at the 2-position, but other possibilities must be considered for tricyclic indoles because the third ring blocks this site; some insight into the dimerisation of tetrahydrocarbazoles

has been obtained by studying homologues with a halogeno, methyl or methoxy substituent in the carbocyclic aromatic ring, but further work with labelled analogues would be required to define the mechanism more precisely. Despite these uncertainties, however, this dimerisation in the nebuliser offers a potential route to the bisindole skeleton, which is found in some heterocycles of pharmaceutical and medicinal significance.

The discovery of the novel dimerisation of certain indoles led to the idea that processes which occur in condensed phase synthesis might be accelerated or modified under positive ion electrospray conditions. This possibility was realised in so far as the formation of C=N bonds by condensation of C=O and NH₂ groups in the nebuliser occurred more rapidly and under milder conditions than is the case in classical solution chemistry. A range of protonated quinoxalines could be readily generated when mixtures of the appropriate 1,2-phenylenediamine and substituted benzil were admitted to the mass spectrometer. Moreover, ions corresponding to the intermediates formed by nucleophilic attack of the diamine on the protonated diketone were also detected. This success illustrates the potential for performing organic synthesis in the droplets formed in the nebuliser of a mass spectrometer. Further work on this theme would involve optimising the conditions under which the C=N bonds are formed, with a view to exploiting the accelerated formation of in the quinoxalines and related heterocycles.

Exploratory work on the possibility of creating bisindoles by modern copper catalysed coupling reactions suggests that this elegant route may be viable, provided that conditions can be found to induce the final cyclisation.

Further work is necessary both to prepare a greater range of suitable intermediates, and to vary the metal in order to achieve the key cyclisation.

Efforts aimed at elaborating the methyl group in the 2-position of indoles by rearrangement of 1-acyl, 1-carboalkoxy or 1-carboaryloxy-2-methylindoles were partially successful, without establishing viable conditions to achieve this potentially useful isomerisation in good yield. The intermolecular nature of the process, which limits the maximum yield to 50 %, appears to be a fatal flaw in this approach unless half the intermediate that is to be rearranged can be sacrificed or recovered and subjected again to the rearrangement. Ironically, however, conditions were established to remove the substituent containing a carbonyl group from the nitrogen atom, thus solving the problem that had been detected by earlier workers who regarded the rearrangement as undesirable side reaction.

Finally, the discovery of an interesting rearrangement of orthogonally protected sulphonamides is significant for two reasons. Firstly, it offers a means of transferring an acyl, carboalkoxy or carboaryloxy group to the aryl ring of a range of sulphonamides, including those containing the pyridine entity. This rearrangement, which is induced by treatment of the protected sulphonamide with lithium diisopropylamide, appears to be compatible with a variety of functional groups, including methyl and methoxy (which are electron-releasing) and halogeno and trifluoromethyl (which are electron attracting). Consequently, it may offer a route to nicotinic acids and related compounds, some of which might be difficult to synthesise by other means. Secondly, the rearrangement does not take place when a nitro group is present in the ring. Therefore, if a sequence of reactions, which involve the

use of lithium diisopropylamine as a base, is to be done on an amino acid or similar substrate that has been protected as a sulphonamide, it is essential to employ the nitrobenzenesulphonamide as the protecting group in order to prevent the rearrangement. Further work is in progress to establish the scope of the rearrangement, to optimise the conditions necessary to induce it, and to exploit it to create compounds of medicinal and pharmaceutical value.

10. EXPERIMENTAL

10.1. General comments

Nuclear Magnetic Resonance: All ^1H NMR spectra were obtained on a Bruker-Spectrospin 400 at 400 MHz, and ^{13}C NMR spectra were obtained at 100 MHz on the same instrument. The samples were prepared using CDCl_3 or DMSO-d_6 as solvent; 10 mg of sample was dissolved in 2 mL of CDCl_3 or DMSO-d_6 . ^1H and ^{13}C NMR were recorded in the range 0-20 ppm and 0-200 ppm respectively. For ^1H NMR, the values for the coupling constant are recorded in Hz as calculated from the spectra. The following abbreviations have been used to describe the signal multiplicity; doublet (d), doublet of doublet (dd), J (coupling constant), multiplet (m), quartet (q), singlet (s) and triplet (t). All other reagents and solvents were obtained from commercial suppliers without further purification.

Raman Spectroscopy: FT-Raman spectra were recorded in the region of $4000\text{-}100\text{ cm}^{-1}$ using a Bruker IFS66 infrared spectrometer with an FRA 106 Raman module attachment equipped with an $\text{Nd}^{3+}/\text{YAG}$ laser operating at 1064 nm as the excitation source. Laser powers of up to 500 mW with spectral resolution of 4 cm^{-1} were used to record each spectrum. Accumulation of 500 or 1000 individual spectral scans was used to improve the signal-to-noise ratio with each accumulated spectrum requiring 15 or 30 mins to record.

Infrared Spectroscopy: The infrared spectra of the compounds were obtained using a Perkin Spectrum 100 FT-IR instrument fitted with DTGS (deuterated triglycine sulphate) detector. Each spectrum was run for a co-

accumulation of 4 scans over a wavenumber range of 4000–650 cm^{-1} . A background spectrum was obtained immediately before the spectra of the compounds were recorded. When comparisons were to be made between the spectra of related compounds, these spectra were run consecutively under identical operating conditions.

Mass Spectrometry: Direct probe EI mass spectrometry analysis was carried out on a Shimadzu QP-2010 quadrupole MS system fitted with a heated solids probe and controlled by 'GCMS solutions' software, version 2.0 (Shimadzu UK Ltd., Milton Keynes, UK). Some solid samples were either placed directly in a disposable glass vial or alternatively, the sample was dissolved in methanol at ~ 1 mg/mL concentration and 1 μL of this solution was then placed into the glass vial. The glass vial was inserted into the end of the solids probe and then placed directly into the mass spectrometer ion source via a vacuum lock. The probe was then heated from ambient to 320 $^{\circ}\text{C}$ over ten minutes. The mass spectrometer used 70 eV electrons to ionise the thermally desorbed sample; data were acquired over the m/z 50 to 600 at a scan speed of 1250 m/z units/sec at unit m/z resolution.

Computational Chemistry: Ab initio DFT calculations were performed with the ORCA program.²⁶⁵ Two density functionals were used the PBE functional²⁶⁶ and the B3LYP function²⁶⁷ which incorporates some Hartree Fock exchange. The triple zeta valence basis set of Weigend et al.²⁶⁸ was used for all calculations. Full geometry optimisation of the molecule was performed in the gas phase and within the COSMO framework for including

an effective dielectric medium.²⁶⁹ Parameters for the effective dielectric constants of chloroform were used in the calculation. The starting geometries for all calculations were taken from the molecular structure in the crystal JAZDOD¹⁰⁴ (code of 1,2,3,4-tetrahydro-4-oxo-carbazole on the Cambridge Crystal Structure Database).¹⁰³ All other conformations of Tautomer 2 were created by editing this structure. The zero-point energies and thermal corrections to the electronic energy were calculated within the harmonic approximation by the numerical calculation of the 2nd derivative matrix of the energy with respect to change in coordinates. Diagonalisation of the mass weighted 2nd derivative matrix was used to calculate the infrared and Raman absorption frequencies and intensities of each tautomer.

10.2. Synthesis

10.2.1 General procedure for the synthesis of Tricyclic Indoles

Phenylhydrazine (0.05 mol) was added dropwise over 30 mins to a solution of cycloalkanone (0.05 mol) and glacial acetic acid (17.2 mL) under N₂. The reaction mixture was heated at reflux; the reaction was monitored by TLC. Upon completion, the hot reaction mixture was poured into a beaker and a solid instantly formed. The solid was allowed to cool to room temperature, filtered, the resultant solid was washed with water followed by 75% EtOH. The crude product was recrystallised from MeOH.

1,2,3,4-tetrahydrocarbazole, 26

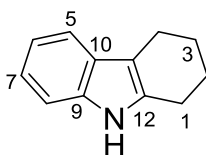

Shiny white platelets (4.62 g, 54%); mp:116–118 °C [lit: 116–118 °C];²⁷⁰ IR: ν_{\max} (ATR) 3397 (N–H), 3050, 2926, 2847, 1620, 1588, 1466, 1439, 1304

cm⁻¹; ¹H NMR: (CDCl₃, 400 MHz); 7.60 (1H, broad singlet, N–H), 7.50 (1H, d, *J* = 6.5 Hz, H–5), 7.31 (1H, m, H–8), 7.12 (2H, m, H–6, H–7), 2.75 (4H, t, 2CH₂, *J* = 5.6 Hz, H–1, H–4), 1.94 (4H, m, 2CH₂, H–2, H–3) ppm; ¹³C NMR: (CDCl₃, 100 MHz); δ 135.6, 134.1, 127.8, 121.0, 119.1, 117.8, 110.4, 110.2, 23.3, 23.2, 20.9 ppm; MS: *m/z* 171 [M⁺], 170 [M–H]⁺, 143 [M–C₂H₄]⁺.

3-methyl-1,2,3,4-tetrahydrocarbazole, 27

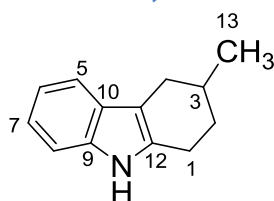

Shiny colourless platelets (3.35 g, 36%); mp: 107–109 °C [lit:108–111 °C];²⁷¹ ν_{\max} (ATR) 3390 (N–H) 3051, 2953, 1620, 1586, 1467, 1452, 1365, 1233; ¹H NMR: (CDCl₃, 400 MHz); δ 7.66 (1H, br s, N–H), 7.49 (1H, d, *J* = 7.4Hz, H–5), 7.29 (1H, m, H–8), 7.09–7.18 (2H, m, H–6, H–7), 2.84 (3H, dd, *J* = 5.1, 15.4 Hz, H–1, H–4), 2.33 (1H, ddt, *J* = 2.0, 9.5, 15.3 Hz, H–4), 2.00 (2H, m, H–2, H–3), 1.61 (1H, m, H–2), 1.18 (3H, d, *J* = 6.5 Hz, H–13) ppm; ¹³C NMR: (CDCl₃, 100 MHz); δ 135.9, 117.7, 110.4, 110.2, 110.1, 31.4, 29.7, 29.4, 22.9, 21.8 ppm; MS: *m/z* 185 [M⁺], 184 [M–H]⁺, 143 [M–C₃H₆]⁺.

2-methyl-1,2,3,4-tetrahydrocarbazole, 28

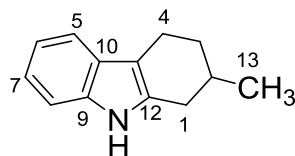

Shiny white platelets (3.46 g, 37%); mp: 98–100 °C [lit: 98–100 °C];²⁷¹ IR: ν_{\max} (ATR) 3386 (N–H), 3053, 2949, 1621, 1572, 1470, 1466, 1371, 1234 cm⁻¹; ¹H NMR: (CDCl₃, 400 MHz); δ 7.63 (1H, br singlet, N–H), 7.50 (1H, d, *J* = 7.4 Hz, H–5), 7.31 (1H, m, H–8), 7.12 (2H, m, H–6, H–7), 2.75 (3H, dd, *J* =

4.4, 11.5 Hz, H-1, H-4), 2.40 (1H, ddt, $J = 1.6, 9.6, 16.0$ Hz, H-1), 2.01 (2H, m, H-3, H-4), 1.54 (1H, m, H-3), 1.17 (3H, d, $J = 6.7$ Hz, H-13) ppm; ^{13}C NMR: (CDCl_3 , 100 MHz); δ 135.8, 134.1, 127.6, 120.9, 119.1, 117.8, 110.4, 109.8, 31.7, 31.5, 29.7, 21.3, 20.4 ppm; MS: m/z 185 [M^+], 184 [M-H^+], 143 [$\text{M-C}_3\text{H}_6^+$].

1,2,3,4-tetrahydrocyclopenta[b]indole, 31

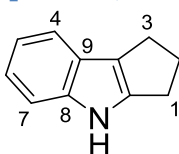

White crystals (3.77 g, 47%); mp: 105–107 °C [Lit: 105–106 °C];²⁷² IR: ν_{max} (ATR) 3394 (N-H), 3046, 2931, 2849, 1617, 1579, 1462, 1444, 1212 cm^{-1} ; ^1H NMR: δ (CDCl_3 , 400 MHz); 7.80 (1H, br s, N-H), 7.48 (1H, m, H-4), 7.31 (1H, m, H-7), 7.12 (2H, m, H-5, H-6), 2.88 (4H, m, 2 CH_2 H-1, H-3), 2.53 (2H, m, H-2) ppm; ^{13}C NMR: (CDCl_3 , 100 MHz); δ 143.8, 141.0, 124.8, 120.5, 119.8, 119.5, 118.5, 111.4, 28.7, 25.9, 24.5 ppm; MS: m/z 157 [M^+], 156 [M-H^+], 129 [$\text{M-C}_2\text{H}_4^+$].

1,2,3,4,5,6-hexahydrocyclohept[b]indole, 32

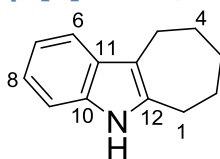

Shiny yellow platlets (5.25 g, 57%); mp: 141–143 °C [lit mp: 141–143 °C];²⁷³ IR: ν_{max} (film) 3387 (N-H), 3058, 2911, 2844, 1618, 1577, 1465, 1425, 1367, 1232 cm^{-1} ; ^1H NMR: (CDCl_3 , 400 MHz); δ 7.62 (1H, br s, N-H), 7.52 (1H, m, H-6), 7.28 (1H, m, H-9), 7.14 (2H, m, H-7, H-8), 2.87 (4H, m, 2 CH_2 , H-1, H-5), 1.92 (2H, m, H-4), 1.74 (4H, m, 2 CH_2 , H-2, H-3) ppm; ^{13}C NMR:

(CDCl₃, 100 MHz); δ 137.4, 134.2, 129.3, 120.6, 119.0, 117.6, 113.7, 110.2, 31.8, 29.6, 28.7, 27.5, 24.7 ppm; MS: m/z 185 [M⁺], 184 [M-H]⁺, 156 [M-C₂H₅]⁺, 143 [M-C₃H₆]⁺.

6,7,8,9,10,11-hexahydrocyclooct[b]indole, 33

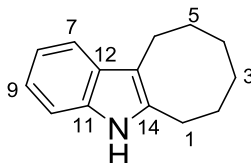

Shiny pale green platelets (5.76 g, 58%); mp: 73–74 °C [lit: 73–74 °C];²⁷⁰ IR: ν_{max} (ATR) 3382 (N–H), 3055, 2918, 2846, 1619, 1580, 1465, 1448, 1437, 1235 cm⁻¹; ¹H NMR: (CDCl₃, 400 MHz); δ 7.78 (1H, s, N–H), 7.55 (1H, dd, J = 2.3, 7.0 Hz, H–7), 7.31 (1H, m, H–10), 7.16 (2H, m, H–8, H–9), 2.91 (4H, m, 2CH₂, H–1, H–6), 1.80 (4H, m, 2CH₂, H–2, H–5), 1.51 (4H, m, 2CH₂, H–3, H–4) ppm; ¹³C NMR: (CDCl₃, 100 MHz); δ 135.7, 135.0, 128.6, 120.6, 118.9, 111.7, 110.3, 29.6, 26.0, 25.9, 22.2 ppm; MS: m/z 199 [M⁺], 198 [M-H]⁺, 156 [M-C₃H₇]⁺, 143 [M-C₄H₈]⁺.

10.2.2. General procedure for the synthesis of Tetradeuteriocycloalkanones

A 5% (w/w) solution of NaOD/D₂O was prepared by cautious addition of sodium metal (1.15 g in small pieces) to D₂O (24.5 g). After cooling to ambient temperature the solution of NaOD/D₂O, cycloalkanone (0.05 mol) and PhCH₂N(Et)₃⁺Cl⁻ (3.0 g) was stirred under N₂ for 2 hr and the reaction was followed by NMR. Once the exchange was completed, the two phase system was allowed to separate and the product was obtained. The partially deuteriated product was subjected to a further two exchanges with a fresh

batch of 5% (w/w) solution of NaOD/D₂O each time and the resulting tetradeuterioketone was isolated with over 95 % deuterium incorporation.

The corresponding labelled tricyclic indoles were synthesised by treating the appropriate tetradeutriocycloalkanones with PhNDND₂ using the same procedure as described in **10.2.1**.

(1,1-²H₂)-2,3,4,9-tetrahydro-1*H*-carbazole, **29**

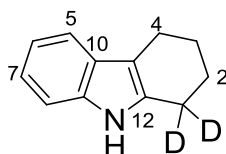

Off white crystals (0.21 g, 45%); mp: 115–118 °C [lit: 116–118 °C];⁸² IR: ν_{\max} (ATR) 3396 (N-H), 3051, 2927, 2849, 2184 (C-D), 2093 (C-D), 1618, 1587, 1467, 1357, 1226; ¹H NMR: (CDCl₃, 400 MHz); δ 7.70 (1H, br s, N-H), 7.50 (1H, m, H-5), 7.30 (1H, m, H-8), 7.11 (2H, m, H-6, H-7), 2.74 (2H, t, J = 5.7 Hz, H-4), 1.91 (4H, m, H-2, H-2) ppm; ¹³C NMR: (CDCl₃, 100 MHz); δ 130.1, 125.7, 122.4, 120.7, 35.7, 28.3, 20.6 ppm; MS: m/z 173 [M⁺], 145 [M-C₂H₄]⁺

3-methyl-(1,1-²H₂)-2,3,4,9-tetrahydro-1*H*-carbazole, **30**

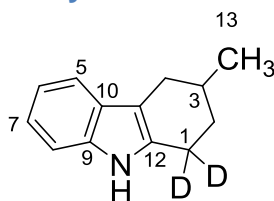

Shiny pale green crystals (0.12 g, 63%); mp: 230–232 °C; IR: ν_{\max} (ATR) 3393 (N-H), 3049, 2922, 2848, 2173 (C-D), 2096 (C-D), 1616, 1581, 1464, 1456, 1425, 1352, 1228; ¹H NMR: (CDCl₃, 400 MHz); δ 7.69 (1H, br s, N-H), 7.48 (1H, m, H-5), 7.3 (1H, m, H-8), 7.12 (2H, m, H-6, H-7), 2.87 (1H, ddd, J = 1.2, 5.0, 15.5 Hz, H-4), 2.31 (1H, dd, J = 9.5, 15.3 Hz, H-4), 1.99 (2H, m, H-

3, H-2), 1.69 (1H, t, $J = 12.3$ Hz, H-2), 1.17 (3H, d, $J = 6.5$ Hz, H-13) ppm.
 ^{13}C NMR: (CDCl_3 , 100 MHz); δ 135.9, 135.8, 133.8, 127.7, 121.0, 119.1, 117.7, 110.3, 31.3, 29.6, 29.4, 21.8 ppm; MS: m/z 187 [M^+], 145 [$\text{M}-\text{C}_3\text{H}_6$] $^+$

(6,6- $^2\text{H}_2$)-5,6,7,8,9,10-hexahydrocyclohepta[*b*]indole, 35

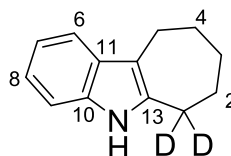

Shiny yellow platelets (0.26 g, 57%); mp: 196–198 °C; IR: ν_{max} (ATR) 3387 (N-H), 3054, 2911, 2843, 2162 (C-D), 1616, 1575, 1463, 1433, 1215; ^1H NMR: (CDCl_3 , 400 MHz); δ 7.69 (1H, br s, N-H), 7.52 (1H, m, H-6), 7.29 (1H, m, H-9), 7.08-7.16 (2H, m, H-7, H-8), 2.85 (2H, m, H-5), 1.94 (2H, m, H-2), 1.82 (4H, m, H-3, H-4) ppm. ^{13}C NMR: (CDCl_3 , 100 MHz); δ 137.4, 134.2, 129.2, 120.6, 120.5, 119.0, 113.8, 110.2, 31.8, 29.3, 27.4, 24.7 ppm; MS: m/z 187 [M^+], 158 [$\text{M}-\text{C}_2\text{H}_5$] $^+$, 145 [$\text{M}-\text{C}_3\text{H}_6$] $^+$.

(6,6- $^2\text{H}_2$)-6,7,8,9,10,11-hexahydro-5*H*-cycloocta[*b*]indole, 36

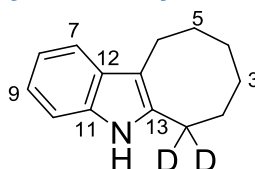

Fine yellow needle-like crystals (0.68 g, 42%); mp: 230–232 °C [Lit 220–221 °C]; IR: ν_{max} (ATR) 3384 (N-H), 3054, 2920, 2847, 2162 (C-D), 1616, 1579, 1467, 1437, 1236; ^1H NMR: (CDCl_3 , 400 MHz) δ 7.83 (1H, br s, N-H), 7.52 (1H, dd, $J = 4.4, 7.4$ Hz, H-7), 7.31 (1H, dd, $J = 4.8, 7.0$, H-10), 7.11 (2H, m, H-8, H-9), 2.85 (2H, t, $J = 6.3$ Hz, H-6), 1.75 (4H, m, H-2, H-5), 1.47 (4H, m, H-3, H-4) ppm. ^{133}C ^{13}C NMR: (CDCl_3 , 100 MHz) 135.9, 135.4, 130.0, 119.1,

118.6, 117.6, 113.8, 109.3, 34.4, 28.5, 27.3, 26.2. 26.5 ppm; δ ; MS: m/z 201 $[M^+]$, 158 $[M-C_3H_7]^+$, 145 $[M-C_4H_8]^+$.

10.2.3. DDQ Oxidation: General procedure

A solution of DDQ (1.14 g, 5.0 mmol) in THF (10 mL) was added to a solution of tricyclic indole (2.5 mmol, 1 equ.) in THF-water (9:1, 10 mL) at 0 °C under N_2 . The reaction mixture was stirred for a 1 hr and the solvent was evaporated to dryness. The residue was dissolved by the addition of EtOAc (200 mL) and washed with saturated $NaHCO_3$ (2 x 50 mL) followed by water (50 mL). The organic phase was dried with $MgSO_4$, filtered and the solvent was removed under reduced pressure. The crude product was recrystallised from aq. methanol.

(1,1- 2H_2)-2,3-dihydro-1*H*-carbazol-4-ol, 15

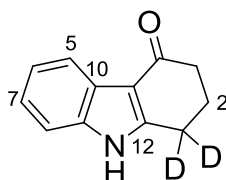

Brown platelets (0.17 g, 61%); mp: 216–228 °C; IR: ν_{max} (ATR) 3200-2800 (N-H), 3056, 2953, 2926, 2862, 1937 (C-D), 1900 (C-D), 1603 (C=O), 1575, 1451, 1317 cm^{-1} ; 1H NMR: (DMSO, 400 MHz); δ 11.85 (1H, br s, O-H), 7.95 (1H, dd, $J = 1.7, 6.6$ Hz, H-5), 7.40 (1H, d, $J = 1.5, 6.5$ Hz, H-8), 7.15 (2H, m, H-6, H-7), 2.43 (2H, t, $J = 6.4$ Hz, H-3), 2.10 (2H, t, $J = 6.6$ Hz, H-2) ppm. ^{13}C NMR: (100 MHz, DMSO); 192.9, 152.2, 135.8, 124.5, 122.4, 121.5, 120.1, 111.5, 111.5, 37.7, 23.2 ppm; MS: m/z 187 $[M^+]$, 159 $[M-C_2H_4]^+$, 131 $[M-C_2H_4-CO]^+$, 104 $[M-C_2H_4-CO-HNC]^+$.

3-methyl-(1,1-²H₂)-2,3-dihydro-1*H*-carbazol-4-ol, 16

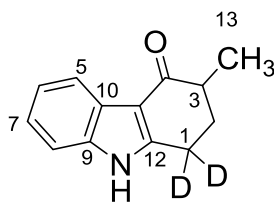

Brown crystals (0.21 g, 42%); mp: 235–237 °C; IR: ν_{\max} (ATR): 3280- 2800 (N-H), 3054, 2927, 2853, 2183 (C-D), 2044 (C-D), 1616 (C=O), 1582, 1449, 1371, 1353, 1319, 1298 cm^{-1} ; ¹H NMR: (DMSO, 400 MHz); δ 11.88 (1H, br s, O-H), 8.02 (1H, m, H-5), 7.45 (1H, dd, $J = 6.2, 1.8$ Hz, H-8), 7.20 (2H, m, H-6, H-7), 2.57 (4H, m, H-3, DMSO), 2.25 (1H, dd, $J = 4.4, 13.1$ Hz, H-2), 1.91 (1H, dd, $J = 10.8, 13.0$ Hz, H-2), 1.21 (3H, d, $J = 7.0$ Hz, H-13) ppm. ¹³C NMR: (100 MHz; DMSO); 195.3, 151.7, 136.1, 124.7, 122.3, 121.4, 121.1, 111.5, 111.1, 40.7, 31.2, 15.3 ppm; MS: m/z 201 [M^+], 159 [$M-C_3H_6$]⁺, 131 [$M-C_3H_6-CO$]⁺, 104 [$M-C_3H_6-CO-HNC$]⁺.

6,6-²H₂-6,7,8,9-tetrahydrocyclohepta[*b*]indol-10-ol, 20

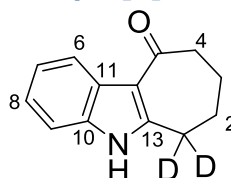

Brown solid (0.19 g, 38%); mp: 246–248 °C; IR: ν_{\max} (ATR) 3280 - 2800 (N-H), 3097, 3042, 2931, 2863, 2163 (C-D), 1596 (C=O), 1572, 1486, 1425, 1406, 1178 cm^{-1} ; ¹H NMR: (400 MHz; DMSO); 11.81 (1H, br s, O-H), 8.20 (1H, dd, $J = 1.7, 6.8$ Hz, H-6), 7.40 (1H, dd, $J = 1.6, 6.6$ Hz, H-9), 7.17 (2H, m, H-7, H-8), 2.71 (2H, t, $J = 6.2$ Hz, H-4), 1.97 (2H, t, $J = 6.3$ Hz, H-2), 1.89 (2H, m, H-3) ppm. ¹³C NMR: (100 MHz; DMSO); 192.4, 149.0, 135.0, 127.3, 122.2, 122.1, 120.9, 113.7, 111.0, 42.6, 24.0, 21.7 ppm; MS: 201 [M^+], 172 [$M-C_2H_5$]⁺, 145 [$M-C_4H_8$]⁺, 117 [$M-C_4H_8-CO$]⁺, 90 [$M-C_4H_8-CO-HNC$]⁺.

(11E)-(6,6-²H₂)-7,8,9,10-tetrahydro-6H-cycloocta[*b*]indol-11-ol, 21

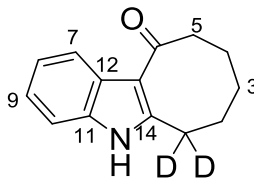

Off white crystals (0.27 g, 50%); mp: 281–285 °C; IR: ν_{\max} (ATR) 3280 - 2800 (N-H), 3097, 2943, 2926, 2852, 2200 (C-D), 1602 (C=O), 1575, 1486, 1437, 1376, 1040 cm^{-1} ; ¹H NMR: (DMSO, 400 MHz); δ 11.83 (1H, br s, O-H), 8.29 (1H, dd, $J = 2.4, 5.6$ Hz, H-7), 7.43 (1H, dd, $J = 2.5, 5.4$ Hz, H-10), 7.19 (2H, m, H-8, H-9), 2.97 (2H, t, $J = 7.2$ Hz, H-5), 1.78 (4H, m, H-2, H-4), 1.45 (2H, m, H-3) ppm. ¹³C NMR: (100 MHz; DMSO); 195.48, 146.4, 134.5, 127.1, 122.0, 121.4, 121.1, 116.0, 111.1, 41.1, 24.3, 23.4, 21.7 ppm; MS: 215 [M^+], 172 [$\text{M}-\text{C}_3\text{H}_7$]⁺, 145 [$\text{M}-\text{C}_5\text{H}_{10}$]⁺, 117 [$\text{M}-\text{C}_5\text{H}_{10}-\text{CO}$]⁺, 90 [$\text{M}-\text{C}_5\text{H}_{10}-\text{CO}-\text{HNC}$]⁺

10.2.4. Synthesis of 2-(2-bromophenyl)-1-phenyl-1-ethanone azine, 125

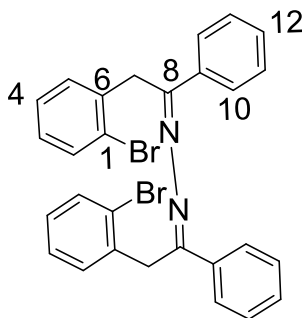

2-(2-bromophenyl)-1-phenyl-1-ethanone (0.58 g, 2 mmol) and $\text{NH}_2\text{NH}_2 \cdot \text{H}_2\text{O}$ (0.62 mL, 12 mmol) and *paratoluenesulphonic acid* (0.0215 g) were dissolved in EtOH (7 mL) and refluxed under N_2 . The reaction was monitored by TLC and when the reaction was completed the mixture was cooled in ice. Ice-water was added to the reaction mixture until it became viscous. The organic layer was extracted with CH_2Cl_2 , dried over MgSO_4 and the solvent was removed under reduced pressure. The crude product was obtained as a

yellow viscous oil.²⁷⁴ Spectroscopic analysis showed the presence of NH₂. To the crude hydrazine (1.3 mmol) was added 2-(2-bromophenyl)-1-phenyl-1-ethanone (1.3 mmol); the mixture was dissolved in EtOH (10 mL), refluxed overnight, cooled in ice and made more viscous by the addition of ice-cold water. The crude product was collected by filtration and the azine was obtained as yellow solid (250 mg, 36%); mp: 220–223 °C; IR: ν_{max} (ATR) 3065, 2963, 2939, 1592, 1568, 1472, 1438, 732 cm⁻¹; ¹H NMR (400 MHz, CDCl₃): 7.83 (2H, dd, *J* = 7.6, 1.6 Hz, H-10 and H-2), 7.59 (1H, dd, *J* = 7.5, 1.5 Hz, H-12), 7.36 (3H, m, H-3 and H-10) 7.06 (3H, m, H-11, H-13 and H-4), 6.97 (3H, m, H-3 and H-5), 4.54 (2H, s, H-7) ppm; ¹³C NMR (100 MHz, CDCl₃): 162.3, 138.3, 132.7, 130.1, 129.7, 128.4, 127.8, 127.6, 127.4, 42.3 ppm; 569 (M+Na)⁺, 547 (M+H)⁺.

10.2.5. 3-Methyl-2-(pyridine-2-sulphonylamino)-butyric acid *tert*butyl ester, 167

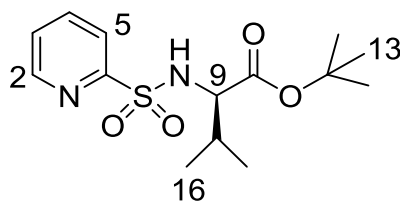

To a solution of 2-mercaptopyridine (6 mmol) in CH₂Cl₂ (30 mL) at 5 °C was added aqueous HCl (4 mL conc. HCl in 13.4 mL H₂O). Aqueous NaClO (20 mL, 11% chlorine content) was added to the solution using an addition funnel over 10 minutes. The solution was stirred at 5 °C for a further 60 minutes and was then extracted with CH₂Cl₂ (2 x 20 mL), dried over sodium sulphate and filtered to give a pale yellow solution. The solvent was reduced in volume until no colour remained (approximately one third the original volume). To this solution was added valine *tert*butyl ester (6 mmol) and triethylamine (6

mmol). The solution was allowed to stand at room temperature for 2 hours and was then quenched with H₂O (20 mL) and extracted with CH₂Cl₂ (2 x 20 mL), dried over sodium sulphate, filtered and the solvent removed to give a solid. This solid was recrystallised from MeOH/H₂O to give the title compound as a colourless crystalline solid (1.64 g, 87%); IR: ν_{max} (ATR) 3257, 2968, 2935, 2875, 1719, 1345, 1177, 1121 cm⁻¹; ¹H NMR (400 MHz, CDCl₃): 8.57 (1H, d, *J* = 4.5 Hz, H-2), 7.90 (1H, d, *J* = 7.8 Hz, H-5), 7.83 (1H, dt, *J* = 7.6, 1.6 Hz, H-4), 7.40 (1H, ddd, *J* = 4.5, 7.6, 1.0 Hz, H-3), 5.33 (1H, d, *J* = 9.3 Hz, NH), 3.99 (1H, dd, *J* = 9.3, 4.4 Hz, H-9), 2.03 (1H, m, H-14), 1.25 (9H, s, H-13), 0.96 (3H, d, *J* = 6.8 Hz, H-15 or 16), 0.80 (3H, d, *J* = 6.8 Hz, H-15 or 16); ¹³C NMR (100 MHz, CDCl₃): 170.4, 149.8, 138.2, 134.7, 126.6, 121.9, 82.1, 62.2, 57.1, 28.1, 19.1, 16.9 ppm.

10.2.6. *N*-*tert*butylcarbamate, 168

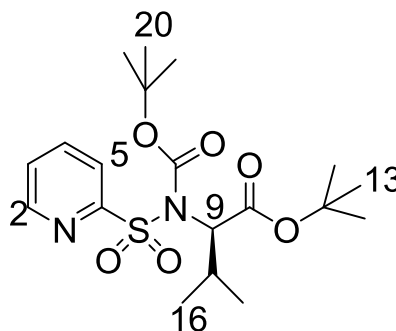

To a solution of 3-methyl-2-(pyridine-2-sulfonylamino)butyric acid *tert*butyl ester (0.22 mmol, 70 mg) in CH₂Cl₂ (2 mL) at room temperature was added di-*tert*butyl dicarbonate (90 mg, 0.41 mmol) and 4-(dimethylamino)pyridine (4 mg, 0.03 mmol). The solution was stirred at room temperature for 10 hours and then quenched with H₂O (5 mL) and extracted with CH₂Cl₂ (2 x 10 mL), dried over sodium sulphate, filtered and the solvent removed to give an oil.

The crude material was purified by column chromatography (2:1 petrol/EtOAc) to give the title compound as a colourless oil (80 mg, 86%); IR: ν_{max} (ATR) 2986, 1731, 1454, 1353, 1149, 1114, 1061 cm^{-1} ; ^1H NMR (400 MHz, CDCl_3): 8.63 (1H, d, $J = 4.3$ Hz, H-2), 8.15 (1H, d, $J = 8.0$ Hz, H-5), 7.86 (1H, dt, $J = 7.7, 1.6$ Hz, H-4), 7.45 (1H, ddd, $J = 4.3, 7.6, 0.7$ Hz, H-3), 4.54 (1H, d, $J = 8.9$ Hz, H-9), 2.48 (1H, m, H-14), 1.32 (9H, s, H-20), 1.28 (9H, s, H-13), 1.15 (3H, d, $J = 6.8$ Hz, H-15 or 16), 0.98 (3H, d, $J = 6.8$ Hz, H-15 or 16); ^{13}C NMR (100 MHz, CDCl_3): 168.5, 157.2, 150.3, 148.5, 137.4, 127.0, 124.2, 84.8, 81.7, 65.5, 29.0, 27.9, 27.8, 22.4, 20.0; MS: 415 ($\text{M}+\text{H}^+$), 359, 331, 303, 160.

10.2.7. Rearrangement of *N*-tertbutylcarbamate, 170

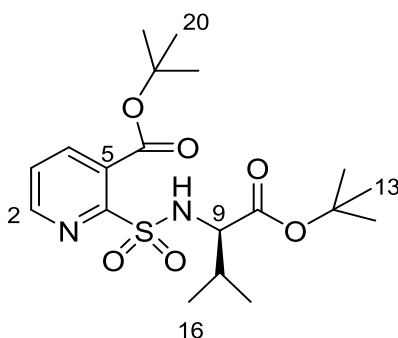

To a solution of *N*-tertbutylcarbamate **5** (20 mg, 0.06 mmol) in THF (1 mL) at -78 $^{\circ}\text{C}$ was added LDA (0.3 mL, 1M in THF). The solution was stirred at -78 $^{\circ}\text{C}$ for 1 hour and then quenched by addition of an aqueous solution of citric acid (1 mL). The mixture was extracted with CH_2Cl_2 (2 x 10 mL), dried over sodium sulphate, filtered and the solvent removed to give a colourless solid (18 mg, 90%); mp: $84\text{--}86$ $^{\circ}\text{C}$; IR: ν_{max} (ATR) 3200, 2975, 1727, 1369, 1307, 1138, 846, 775 cm^{-1} ; ^1H NMR (400 MHz, CDCl_3): 8.57 (1H, dd, $J = 4.7, 1.8$ Hz, H-2), 7.95 (1H, dd, $J = 7.8, 1.8$ Hz, H-4), 7.42 (1H, dd, $J = 4.8, 7.8$ Hz, H-3), 5.98 (1H, d, $J = 9.2$ Hz, NH), 4.00 (1H, dd, $J = 9.2, 4.0$ Hz, H-9), 2.07 (1H,

m, H-14), 1.57 (9H, s, H-20), 1.22 (9H, s, H-13), 0.97 (3H, d, $J = 6.7$ Hz, H-15 or 16), 0.84 (3H, d, $J = 6.7$ Hz, H-15 or 16); ^{13}C NMR (100 MHz, CDCl_3): 168.5, 157.2, 150.3, 148.5, 137.4, 127.0, 124.2, 84.8, 81.7, 65.5, 29.0, 27.9, 27.8, 22.4, 20.0; MS: 415 ($\text{M}+\text{H}$) $^+$, 359, 331, 303, 160; HRMS: found ($\text{M}+\text{H}$) $^+$ 415.1905, $\text{C}_{19}\text{H}_{30}\text{N}_2\text{O}_6\text{S}$ requires ($\text{M}+\text{H}$) 415.1897 - This and all other HRMS data presented gave a measured value of m/z within 1 mmu of the theoretical m/z value.

10.2.8. General Synthesis of *N*-acylated compounds

To a solution of pyridine-2-sulphonic acid benzylamide (234 mg, 1 mmol) in THF (10 mL) at 0 °C was added NaH (80 mg, 2 mmol, 60% dispersion in mineral oil), followed by the appropriate acid chloride (1.2 mmol). The solution was stirred at room temperature for 1 hour and then quenched with H_2O (5 mL) and extracted with CH_2Cl_2 (2 x 10 mL), dried over sodium sulphate and filtered to give an oil. The crude material was purified by column chromatography (3:1 petrol/EtOAc) to give the acylated product.

N-benzyl-*N*-(pyridin-2-ylsulphonyl)acetamide, 175

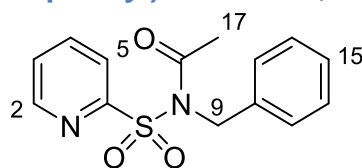

Colourless solid (275.50 mg, 95%), mp: 78–80 °C; IR: ν_{max} (ATR) 3064, 1701, 1427, 1353, 1187, 1117 cm^{-1} ; ^1H NMR (400 MHz, CDCl_3): 8.67 (1H, d, $J = 5.1$ Hz, H-2), 7.93 (1H, d, $J = 8.2$ Hz, H-5), 7.87 (1H, dt, $J = 7.5, 1.7$ Hz, H-4), 7.51 (1H, ddd, $J = 7.6, 4.6, 1.0$ Hz, H-3), 7.37–7.34 (2H, m, Ph), 7.28–7.22 (3H, m, Ph), 5.08 (2H, s, H-9), 2.55 (3H, s, H-17) ppm; ^{13}C NMR (100

MHz, CDCl₃):173171.4, 157.1, 150.0, 138.0, 136.3, 128.4, 128.1, 127.5, 127.3, 122.8, 50.1, 15.3 ppm; MS: 291 (M+H)⁺, 249.

Methylbenzyl(pyridin-2-ylsulphonyl)carbamate, 176

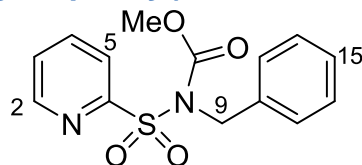

Colourless solid (247.05 mg, 81%), mp: 72–74 °C; IR: ν_{\max} (ATR) 3032, 2968, 1743 (C=O), 1580, 1429, 1348, 1306, 1239, 1118 cm⁻¹; ¹H NMR (CDCl₃, 400 MHz): δ 8.62 (1H, d, J = 4.4 Hz, H-2), 8.07 (1H, d, J = 7.8 Hz, H-5), 7.87 (2H, m, H-3, 4), 7.19-7.50 (5H, m, Ph), 5.13 (2H, s, H-9), 3.55 (3H, s, H-17) ppm; ¹³C NMR (100 MHz, CDCl₃): 156.7, 151.0, 150.0, 137.9, 136.9, 128.5, 128.1, 127.7, 127.4, 123.9, 54.1, 51.2 ppm; MS: 307 (M+H)⁺; HRMS: found (M+H)⁺ 307.0751, C₁₄H₁₄N₂O₄S requires (M+H) 307.0747.

N-benzyl-*N*-(pyridin-2-ylsulphonyl)hexanamide, 177

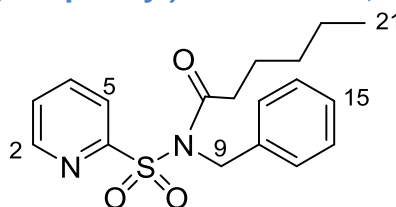

Colourless oil (283.72 mg, 82%); IR: ν_{\max} (ATR) 2956, 2930, 2871, 1703, 1355, 1168, 1115 cm⁻¹; ¹H NMR (400 MHz, CDCl₃): 8.55 (1H, m, H-2), 7.91 (1H, d, J = 8.0 Hz, H-5), 7.77 (1H, dt, J = 8.0, 1.4 Hz, H-4), 7.38 (1H, ddd, J = 8.0, 4.6, 0.8 Hz, H-3), 7.33 (2H, d, J = 7.2 Hz, H-11, 12), 7.21 (2H, t, J = 7.2 Hz, H-13,14), 7.15 (1H, m, H-15), 5.05 (2H, s, H-9), 2.71 (2H, t, J = 7.2 Hz, H-17), 1.51 (2H, p, J = 7.2 Hz, H-18), 1.10-1.18 (4H, m, H-19,20), 0.76 (3H, t, J = 7.2 Hz, H-21); ¹³C NMR (100 MHz, CDCl₃): 174.2, 156.9, 150.0, 138.2,

136.8, 128.5, 127.6, 127.5, 123.0, 50.1, 36.2, 31.0, 24.4, 22.3, 14.0; MS: 347 (M+H)⁺, 249, 214, 204.

***N*-benzyl-2-chloro-*N*-(pyridin-2-ylsulphonyl)propanamide, 178**

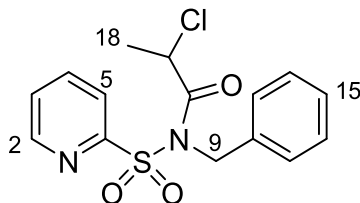

Colourless oil (263.64 mg, 78%); IR: ν_{\max} (ATR) 2987, 1707, 1452, 1428, 1361, 1167, 1116 cm^{-1} ; ¹H NMR (400 MHz, CDCl₃): δ 8.54 (1H, dt, J = 4.8, 1.5 Hz, H-2), 7.75 (1H d, J = 7.7 Hz, H-5), 7.71 (1H, dt, J = 7.7, 1.5 Hz, H-4), 7.38 (1H, ddd, J = 7.7, 4.8, 1.7 Hz, H-3), 7.20 - 7.09 (5H, m, Ph), 5.46 (1H, q, J = 6.6 Hz, H-17), 5.05 (1H, d, J = 15.3 Hz, H-9), 4.97 (1H, d, J = 15.3 Hz, H-9), 1.57 (3H, d, J = 6.6 Hz, H-18); ¹³C NMR: (100 MHz, CDCl₃): 171.5, 156.3, 150.0, 138.2, 135.6, 128.5, 128.0, 127.8, 127.6, 122.7, 52.7, 50.2, 21.6 ppm.

***N*-benzyl-2,2-dimethyl-*N*-(pyridin-2-ylsulphonyl)propanamide, 179**

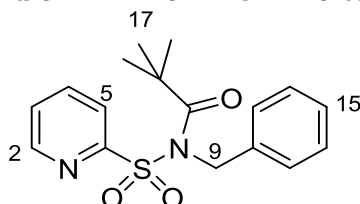

Colourless solid (249.75 mg, 75%), mp: 118–120 °C; IR: ν_{\max} (ATR); 3088, 3064, 3034, 3004, 2969, 2938, 1657 (C=O), 1607, 1581, 1338, 1321, 1253, 1178, 1155 cm^{-1} ; ¹H NMR (400 MHz, CDCl₃): IR: ν_{\max} (ATR): 3034, 3004, 2938, 1657, 1338, 1321, 1178, 1102 cm^{-1} ; 8.65 (1H, dd, J = 4.1, 1.2 Hz, H-2), 8.16 (1H, d, J = 8.0 Hz, H-5), 7.95 (1H, dt, J = 8.0, 1.2 Hz, H-4), 7.52 (1H, dd, J = 8.0, 4.1 Hz, H-3), 7.36-7.44 (3H, m, Ph), 7.26-7.31 (2H, m, Ph), 5.34 (2H, s, H-9), 1.18 (9H, s, H-17); ¹³C NMR (100 MHz, CDCl₃): 180.5, 157.4, 149.6,

138.0, 137.2, 128.7, 128.0, 127.4, 126.4, 123.7, 51.7, 42.0, 27.8; MS: 333 (M+H)⁺, 249.

Tertbutylbenzyl(pyridin-2-ylsulphonyl)carbamate, 180

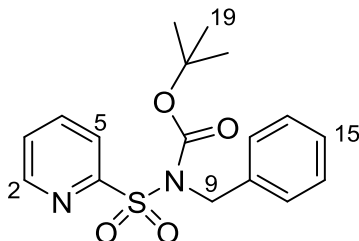

Colourless solid (330.60 mg, 95%), mp: 108–110 °C; IR: ν_{\max} (ATR) 2986, 1731, 1353, 1149, 1113, 1061, 731 cm^{-1} ; ^1H NMR (400 MHz, CDCl_3): δ 8.59 (1H, dt, $J = 4.4, 1.2$ Hz, H-2), 8.00 (1H br d, $J = 7.7$ Hz, H-5), 7.83 (1H, dt, $J = 7.7, 1.5$ Hz, H-4), 7.44–7.40 (3H, m, Ph, H-3), 7.29–7.24 (2H, m, Ph), 7.19 (1H, m, Ph), 5.02 (2H, s, H-9), 1.13 (9H, s, H-19); ^{13}C NMR: (CDCl_3 , 100 MHz): 157.3, 150.9, 149.9, 137.8, 137.6, 128.4, 127.9, 127.5, 127.1, 123.4, 84.6, 60.4, 51.0, 27.7 ppm; HRMS: found (M+H)⁺ 349.1217, $\text{C}_{17}\text{H}_{20}\text{N}_2\text{O}_4\text{S}$ requires (M+H) 349.1217.

N-benzyl-*N*-(pyridin-2-ylsulphonyl)benzamide, 181

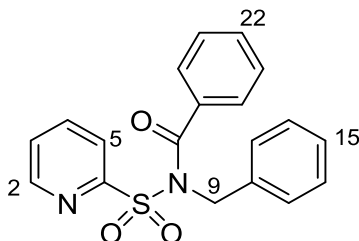

Colourless solid (348.48 mg, 99%), mp: 58–60 °C; IR: ν_{\max} (ATR) 3059, 3033, 1677, 1661, 1358, 1320, 1181 cm^{-1} ; ^1H NMR (400 MHz, CDCl_3): 8.73 (1H, dd, $J = 5.7, 1.6$ Hz, H-2), 8.03 (1H, d, $J = 8.0$ Hz, H-5), 7.91 (1H, dt, $J = 8.0, 1.6$ Hz, H-4), 7.54 (1H, ddd, $J = 8.0, 4.7, 1.0$ Hz, H-3), 7.25–7.47 (10H, m, Ph), 5.15 (2H, s, H-9); ^{13}C NMR (100 MHz, CDCl_3): 171.2, 156.7, 150.0, 138.0, 136.6, 134.7, 131.6, 128.6, 128.1, 128.0, 127.8, 127.7, 127.4, 52.0;

MS: 353 (M+H)⁺, 249, 214; HRMS: found (M+H)⁺ 353.0961, C₁₉H₁₆N₂O₃S requires (M+H) 353.0954.

***N*-benzyl-2-phenyl-*N*-(pyridin-2-ylsulphonyl)butanamide, 182**

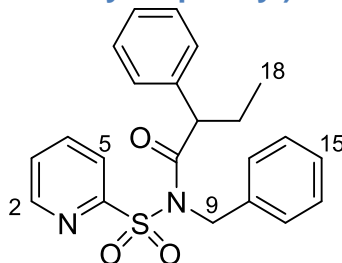

Colourless solid (294.14 mg, 77%), mp: 105–107 °C; IR: ν_{max} (ATR) 2964, 2926, 2874, 1697, 1454, 1354, 1181, 1115 cm⁻¹; ¹H NMR (400 MHz, CDCl₃): 8.58 (1H, br d, *J* = 4.6 Hz, H-2), 8.08 (1H, d, *J* = 8.1 Hz, H-5), 7.91 (1H, td, *J* = 7.7, 1.7 Hz, H-4), 7.51 (ddd, *J* = 7.7, 4.5, 1.0 Hz, H-3), 7.42–7.22 (10H, m, Ph), 7.06–7.02 (2H, m, Ph), 5.32 (1H, d, *J* = 16.4 Hz, H-9), 4.92 (1H, d, *J* = 16.4 Hz, H-9), 4.02 (1H, t, *J* = 5.8 Hz, H-16), 1.97 (1H, m, H-17), 1.60 (1H, m, H-17), 0.71 (3H, t, *J* = 7.2 Hz, H-18); ¹³C NMR (100 MHz, CDCl₃): 203.0, 153.6, 150.0, 136.8, 136.5, 136.1, 135.8, 128.6, 127.9, 127.8, 126.6, 126.2, 115.8, 47.8, 42.9, 27.6 ppm.

10.2.9. General procedure for the rearrangement

To a solution of the *N*-acylated compound (0.2 mmol) in THF (1 mL) at -78 °C was added a 0.66 M solution of LDA (0.3 mL). The solution was stirred at -78 °C for 30 mins and then quenched with citric acid solution (5 mL) and extracted with CH₂Cl₂ (2 x 10 mL), dried over sodium sulphate and filtered to give an oil. The crude material was purified by column chromatography (3:1 petrol/EtOAc) to give the nicotinic acid derivative.

Methyl-2-(benzylsulphamoyl)pyridine-3-carboxylate, 183

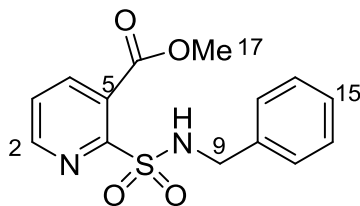

Colourless oil (50.02 mg, 82%); IR: ν_{\max} (ATR) 3127, 2958, 2862, 1739, 1584, 1436, 1336, 1304, 1224, 1142 cm^{-1} ; ^1H NMR (400 MHz, CDCl_3): δ 8.64 (1H, dd, $J = 5.0, 1.8$ Hz, H-2), 7.95 (1H, dd, $J = 7.6, 1.5$ Hz, H-4), 7.46 (1H, $J = 7.8, 4.9$ Hz, H-3), 7.17 (5H, m, Ph), 5.68 (1H, t, $J = 6.2$ Hz, NH), 4.24 (2H, d, $J = 6.3$ Hz, H-9), 3.91 (3H, s, H-17) ppm; ^{13}C NMR: (CDCl_3 , 400 MHz); 171.2, 166.4, 150.6, 138.4, 136.3, 128.7, 128.1, 127.7, 126.1, 53.7, 48.0 ppm; MS: 307 (M+H)⁺; HRMS: found (M+H)⁺ 307.0751, $\text{C}_{14}\text{H}_{14}\text{N}_2\text{O}_4\text{S}$ requires (M+H) 307.0747.

N-benzyl-3-(2-phenyl butanoyl)pyridine-2-sulphonamide, 184

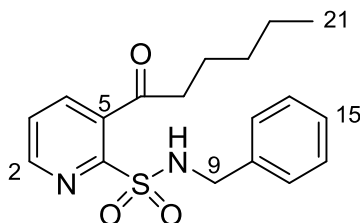

Colourless oil (66.43 mg, 96%); IR: ν_{\max} (ATR) 3276, 2955, 2930, 2870, 1703, 1455, 1403, 1333, 1165; ^1H NMR (400 MHz, CDCl_3): 8.58 (1H, dd, $J = 4.5, 1.6$ Hz, H-2), 7.67 (1H, dd, $J = 8.0, 1.6$ Hz, H-4), 7.44 (1H, dd, $J = 8.0, 4.5$ Hz, H-3), 7.15 – 7.18 (5H, m, Ph), 5.55 (1H, t, $J = 6.2$ Hz, NH), 4.20 (2H, d, $J = 6.2$ Hz, H-9), 2.86 (2H, t, $J = 7.5$ Hz, H-17), 1.63-1.71 (2H, m, H-18), 1.26-1.30 (4H, m, H-19,20), 0.83 (3H, t, $J = 7.3$ Hz, H-21); ^{13}C NMR (CDCl_3 , 100 MHz): 204.0, 153.5, 150.0, 137.0, 136.2, 135.8, 128.6, 128.0, 127.8, 126.2, 47.8, 43.8, 31.1, 23.3, 22.5, 14.0 ppm.

***N*-benzyl-3-(hexanoyl)pyridine-2-sulphonamide, 185**

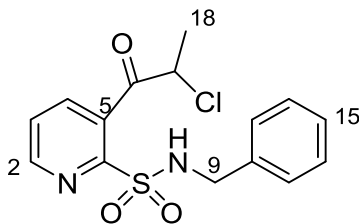

Colourless oil (51.38 mg, 76%); IR: ν_{\max} (ATR): 3029, 1717, 1455, 1338, 1216, 1167, 753 cm^{-1} ; ^1H NMR (400 MHz, CDCl_3): 8.60 (1H, dd, $J = 4.7, 1.5$ Hz, H-2), 7.80 (1H, dd, $J = 7.9, 1.8$ Hz, H-4), 7.47 (1H, dd, $J = 7.9, 4.8$ Hz, H-3), 7.21 – 7.11 (5H, m, Ph), 5.45 (1H, t, $J = 6.6$ Hz, NH), 4.96 (1H, q, $J = 6.9$ Hz, H-17), 4.19 (1H, dd, $J = 14.1, 6.6$ Hz, H-9), 4.10 (1H, dd, $J = 14.1, 6.6$ Hz, H-9), 1.73 (1H, d, $J = 6.9$ Hz, H-18) ppm; ^{13}C NMR: 196.6, 153.1, 150.7, 138.4, 135.8, 134.7, 128.8, 128.0, 127.9, 126.1, 58.2, 47.8, 29.7 ppm.

***N*-benzyl-3-(2,2-dimethylpropanoyl)pyridine-2-sulphonamide, 186**

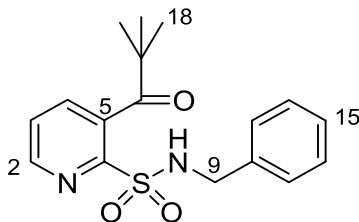

Colourless oil (58.61 mg, 88%); IR: ν_{\max} (ATR) 3320, 2967, 1697, 1578, 1455, 1335; ^1H NMR (400 MHz, CDCl_3): 8.58 (1H, dd, $J = 4.7, 1.8$ Hz, H-2), 7.62 (1H, dd, $J = 7.8, 1.8$ Hz, H-4), 7.42 (1H, dd, $J = 7.8, 4.7$ Hz, H-3), 7.13–7.18 (5H, m, Ph), 4.16 (2H, s, H-9), 1.25 (9H, s, H-18); ^{13}C NMR: 210.9, 153.1, 149.5, 136.5, 136.2, 134.7, 128.7, 128.0, 127.8, 125.8, 47.7, 45.3, 27.6; MS 333 ($\text{M}+\text{H}$)⁺, 279, 249, 103; HRMS: found ($\text{M}+\text{H}$)⁺ 333.1274, $\text{C}_{17}\text{H}_{20}\text{N}_2\text{O}_3\text{S}$ requires ($\text{M}+\text{H}$) 333.1267.

Tertbutyl-2-(benzylsulphamoyl)pyridine-3-carboxylate, 187

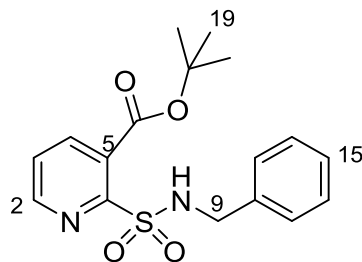

Colourless oil; (59.86 mg, 86%) ^1H NMR (400 MHz, CDCl_3): IR: ν_{max} (ATR) 8.60 (1H, dd, $J = 4.9, 1.6$ Hz, H-2), 7.95 (1H, dd, $J = 7.7, 1.8$ Hz, H-4), 7.44 (1H, dd, $J = 7.7, 4.9$ Hz, H-3), 7.21–7.16 (5H, m, Ph), 5.72 (1H, t, $J = 6.3$ Hz, NH), 4.23 (1H, d, $J = 6.5$ Hz, H-9), 155 (9H, s, H-19) ppm; ^{13}C NMR: 165.2, 155.0, 150.0, 138.5, 136.5, 129.7, 128.6, 128.0, 127.8, 126.0, 84.8, 48.0, 27.; HRMS: found $(\text{M}+\text{H})^+$ 349.1220, $\text{C}_{17}\text{H}_{20}\text{N}_2\text{O}_4\text{S}$ requires $(\text{M}+\text{H})$ 349.1217

N-benzyl-3-(phenylcarbonyl)pyridine-2-sulphonamide, 188

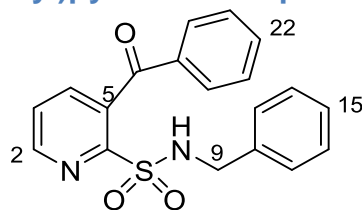

Colourless solid (33.10 mg, 78%), mp: 137–138 $^{\circ}\text{C}$; IR: ν_{max} (ATR) 3191, 1669, 1596, 1581, 1453, 1338, 1316, 1285, 1164, 1132; ^1H NMR (400 MHz, CDCl_3): 8.53 (1H, dd, $J = 4.6, 1.5$ Hz, H-2), 7.67–7.71 (3H, m, H-18, 19, 20), 7.54 (1H, d, $J = 7.7$ Hz, H-4), 7.47 (1H, dd, $J = 7.7, 4.5$ Hz, H-3), 7.39 (2H, t, $J = 8.0$ Hz, H-20, 21), 7.13 – 7.19 (5H, m, Ph), 4.22 (2H, s, H-9); ^{13}C NMR: 194.2, 154.8, 150.1, 137.1, 136.2, 135.9, 139.9, 134.4, 130.2, 128.8, 128.6, 127.9, 127.8, 125.8, 47.8; MS: 353 $(\text{M}+\text{H})^+$, 246.

***N*-benzyl-3-(2-phenylbutanoyl)pyridine-2-sulphonamide, 189**

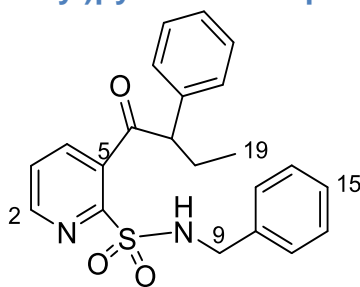

Colourless solid (68.76 mg, 90%), mp: 108–110 °C; IR: ν_{max} (ATR) 2925, 2850, 1703, 1454, 1334, 1204, 1164, 1132, 730 cm^{-1} ; ^1H NMR (400 MHz, CDCl_3): δ 8.45 (1H, dd, $J = 4.7, 1.8$ Hz, H-2), 7.23–7.09 (11H, m, Ph, H-3), 6.94 (1H, dd, $J = 7.8, 1.8$ Hz, H-4), 5.53 (1H, t, $J = 14.0, 6.5$ Hz, NH), 4.21 (1H, dd, $J = 14.0, 6.5$ Hz, H-9), 4.1–4.09 (2H, m, H-9, H-17), 2.22 (1H, m, H-18), 1.94 (1H, m, H-18), 0.78 (3H, t, $J = 8.2$ Hz, H-19); ^{13}C NMR (CDCl_3 , 100 MHz): 203.0, 153.6, 150.0, 136.8, 136.5, 136.1, 135.8, 128.6, 127.9, 127.8, 126.6, 126.2, 115.8, 47.8, 42.9, 27.6 ppm.

10.2.10. General Procedure for Synthesis of Sulphonamides

To a solution of aryl sulphonyl chloride (10 mmol) in CH_2Cl_2 (50 mL) was added isopropylamine (10 mmol) and triethylamine (20 mmol). The resulting solution was stirred for 30 mins at room temperature and then diluted with water (20 mL). The mixture was extracted with CH_2Cl_2 (2 x 10 mL), dried over sodium sulphate and filtered to give the crude sulphonamide. If required, the sulphonamide was further purified by recrystallisation from EtOH/water.

***Tert*butyl-3-methyl-2-(4-methylphenylsulphonamido)butanoate, 192**

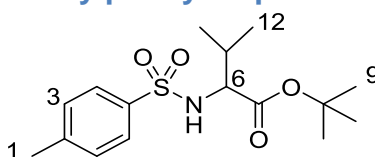

Colourless solid (3.11 g, 95%), mp 155–157 °C; IR: ν_{\max} (ATR) 3280, 2970, 1715, 1341, 1159 cm^{-1} ; ^1H NMR (400 MHz, CDCl_3): 7.74 (2H, d, $J = 8.5$ Hz, H-4), 7.29 (2H, d, $J = 8.5$ Hz, H-3), 5.08 (1H, d, $J = 9.2$ Hz, NH), 3.63 (1H, dd, $J = 9.2, 5.0$ Hz, H-6), 2.41 (3H, s, H-1), 2.06 (1H, m, H-10), 1.24 (9H, s, H-9), 1.01 (3H, d, $J = 6.4$ Hz, H-11/12), 0.86 (3H, d, $J = 6.4$ Hz, H-11/12); ^{13}C NMR (100 MHz, CDCl_3): 170.4, 143.5, 136.8, 129.6, 127.4, 82.2, 61.2, 31.7, 27.7, 21.5, 19.1, 17.0 ppm; MS: 350 ($\text{M}+\text{Na}$) $^+$, 272 ($\text{M}+\text{H}-\text{C}_4\text{H}_8$) $^+$; HRMS: found ($\text{M}+\text{Na}$) $^+$ 350.1398, $\text{C}_{16}\text{H}_{24}\text{NO}_4\text{S}$ requires ($\text{M}+\text{H}$) $^+$ 350.1397.

***N*-isopropyl-4-methylbenzenesulphonamide, 200**

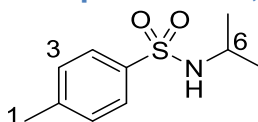

Colourless solid (1.96 g, 92%), mp 49–51 °C (lit: 48–50 °C);^{275, 276} IR: ν_{\max} (ATR) 3261, 2977, 1596, 1388, 1298 cm^{-1} ; ^1H NMR (400 MHz, CDCl_3): 7.79 (2H, d, $J = 8.1$ Hz, H-4), 7.31 (2H, d, $J = 8.1$ Hz, H-3), 4.72 (1H, d, $J = 6.9$ Hz, NH), 3.45 (1H, oct, $J = 6.9$ Hz, H-6), 2.44 (3H, s, H-1), 1.09 (6H, d, $J = 6.9$ Hz, H-7/8); ^{13}C NMR (100 MHz, CDCl_3): 143.2, 138.2, 129.6, 127.0, 46.0, 23.7, 21.5 ppm; MS: 236 ($\text{M}+\text{Na}$) $^+$, 172 ($\text{M}+\text{H}-\text{C}_3\text{H}_6$) $^+$; HRMS: found ($\text{M}+\text{Na}$) $^+$ 236.0716, $\text{C}_{10}\text{H}_{15}\text{NO}_2\text{S}$ requires ($\text{M}+\text{Na}$) $^+$ 236.0716.

***N*-isopropylbenzenesulphonamide, 201**

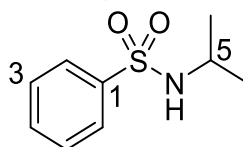

Colourless oil (1.89 g, 95%); IR: ν_{\max} (ATR) 3277, 2975, 1447, 1322, 1156 cm^{-1} ; ^1H NMR (400 MHz, CDCl_3) 7.92 (2H, d, $J = 7.3$ Hz, H-2), 7.56 (1H, t, $J = 7.3$ Hz, H-4), 7.50 (2H, t, $J = 7.3$ Hz, H-3), 5.16 (1H, d, $J = 6.1$ Hz, NH), 3.45 (1H, oct, $J = 6.1$ Hz, H-5), 1.07 (6H, d, $J = 6.4$ Hz, H-6/7); ^{13}C NMR (100

MHz, CDCl₃): 141.1, 132.4, 129.1, 127.0, 46.1, 23.6 ppm; MS: 222 (M+Na)⁺, 200 (M+H)⁺, 158 (M+H-C₃H₆)⁺; HRMS: found (M+H)⁺ 200.0739, C₉H₁₃NO₂S requires (M+H)⁺ 200.0740.

***N*-isopropyl-4-methoxybenzenesulphonamide, 202**

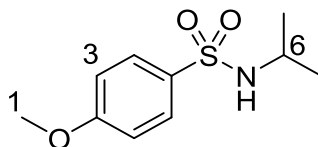

Colourless solid (2.08 g, 91%), mp 55–57 °C; IR: ν_{\max} (ATR) 3263, 2971, 1598, 1416, 1264, 1093 cm⁻¹; ¹H NMR (400 MHz, CDCl₃): 7.84 (2H, d, *J* = 8.7 Hz, H-4), 6.98 (2H, d, *J* = 8.7 Hz, H-3), 4.83 (1H, d, *J* = 6.5 Hz, NH), 3.87 (3H, s, H-1), 3.42 (1H, oct, *J* = 6.5 Hz, H-6), 1.07 (6H, d, *J* = 6.5 Hz, H-7/8); ¹³C NMR (100 MHz, CDCl₃): 162.7, 132.7, 129.1, 114.2, 55.6, 46.0, 23.7 ppm; MS: 252 (M+Na)⁺, 230 (M+H)⁺; HRMS: found (M+H)⁺ 230.0847, C₁₀H₁₅NO₃S requires (M+H)⁺, 230.0845.

***N*-isopropyl-4-nitrobenzenesulphonamide, 203**

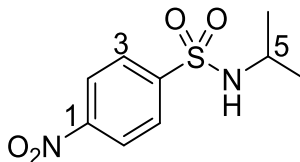

Light brown solid (1.78 g, 84%); mp 114–115 °C (lit: 114–115 °C);²⁷⁶ IR: ν_{\max} (ATR): 3245, 2980, 1521, 1346 cm⁻¹; ¹H NMR (400 MHz, CDCl₃): 8.38 (2H, d, *J* = 89.2 Hz, H-2), 8.10 (2H, d, *J* = 9.2 Hz, H-3), 4.86 (1H, d, *J* = 7.8 Hz, NH), 3.57 (1H, oct, *J* = 6.4 Hz, H-5), 1.14 (6H, d, *J* = 6.4 Hz, H-6/7); ¹³C NMR (100 MHz, CDCl₃): 150.0, 147.2, 128.2, 124.4, 46.6, 23.8 ppm; MS: 267 (M+Na)⁺; HRMS: found (M+Na)⁺ 267.0408, C₉H₁₂N₂O₄S requires (M+Na)⁺ 267.0410.

10.2.11. General procedure for 'Boc' protection

To a solution of sulphonamide (426 mg, 2 mmol) in DCM (10 mL) at ambient temperature was added Boc_2O (480 mg, 2.2 mmol), and 4-(dimethylamino)pyridine (5 mg). The solution was stirred at room temperature for 1 hr and was then quenched with H_2O (5 mL) and extracted with CH_2Cl_2 (2 x 10 mL), dried over sodium sulphate and filtered to give the product that was used without further purification.

Tertbutyl-2-(*N*-(tert-butoxycarbonyl)-4-methylphenylsulphonamido)-3-methylbutanoate, 193

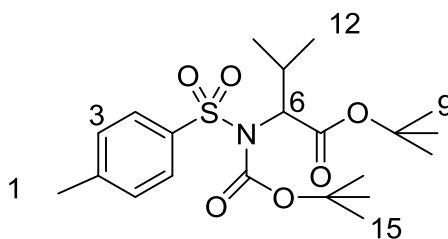

Colourless oil (669.2 mg, 78%); IR: ν_{max} (ATR) 2979, 1734, 1353, 1144 cm^{-1} ; ^1H NMR (400 MHz, CDCl_3): 7.92 (2H, d, $J = 8.2$ Hz, H-4), 7.28 (2H, d, $J = 8.2$ Hz, H-3), 4.15 (1H, d, $J = 9.1$ Hz, H-6), 2.55 (1H, m, H-11), 2.42 (3H, s, H-1), 1.40 (9H, s, H-12 or 15), 1.33 (9H, s, H-12 or 15); ^{13}C NMR (100 MHz, CDCl_3): 168.5, 150.2, 144.1, 137.0, 128.9, 128.8, 84.5, 81.9, 65.2, 28.5, 28.0, 27.8, 22.4, 21.6, 19.9 ppm; MS: 422 ($\text{M}+\text{Na}$) $^+$; HRMS: found ($\text{M}+\text{Na}$) $^+$ 422.1607, $\text{C}_{19}\text{H}_{29}\text{NO}_6\text{S}$ requires ($\text{M}+\text{Na}$) $^+$ 422.1608.

Tertbutylisopropyl(tosyl)carbamate, 204

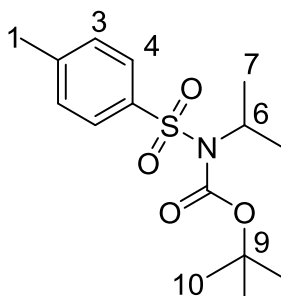

Colourless solid (459.90 mg, 73%); mp: 83–85 °C; IR: ν_{\max} (ATR): 2978, 1713, 1353, 1146 cm^{-1} ; ^1H NMR (400 MHz, CDCl_3): 7.78 (2H, d, $J = 8.3$ Hz, H-4), 7.30 (2H, d, $J = 8.3$ Hz, H-3), 4.77 (1H, sept, $J = 7.2$ Hz, H-6), 2.44 (3H, s, H-1), 1.47 (6H, d, $J = 7.2$ Hz, H-7), 1.37 (9H, s, H-12); ^{13}C NMR (100 MHz, CDCl_3): 150.8, 143.7, 138.1, 129.2, 127.5, 83.9, 51.1, 27.9, 21.6, 21.4 ppm; MS: 336 ($\text{M}+\text{Na}$) $^+$, 314 ($\text{M}+\text{H}$) $^+$, 258 ($\text{M}+\text{H}-\text{C}_4\text{H}_8$) $^+$; HRMS: found ($\text{M}+\text{H}$) $^+$ 314.1422, $\text{C}_{15}\text{H}_{23}\text{NO}_4\text{S}$ requires ($\text{M}+\text{H}$) $^+$ 314.1421.

Tertbutylisopropyl(phenylsulphonyl)carbamate, 207

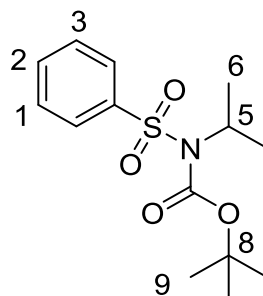

Colourless solid (451.5 mg, 75%); mp: 55–57 °C; IR: ν_{\max} (ATR): 2937, 2979, 1724, 1394, 1143 cm^{-1} ; ^1H NMR (400 MHz, CDCl_3): 7.87 (2H, d, $J = 7.1$ Hz, H-3), 7.56 (1H, t, $J = 7.1$ Hz, H-1), 7.48 (2H, t, $J = 7.1$ Hz, H-2), 4.75 (1H, sept, $J = 6.6$ Hz, H-5), 1.45 (6H, d, $J = 6.6$ Hz, H-6), 1.31 (9H, s, H-9) ppm; ^{13}C NMR (100 MHz, CDCl_3): 150.6, 141.0, 132.9, 128.7, 84.0, 51.2, 27.8, 21.3 ppm.

Tertbutylisopropyl((4-methoxyphenyl)sulphonyl)carbamate, 210

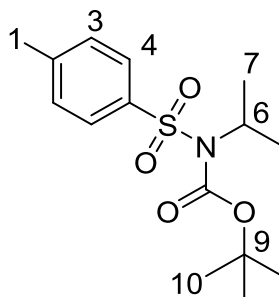

Colourless solid (529.6 mg, 80%); mp: 72–74 °C; IR: ν_{max} (ATR): 2978, 2938, 1721, 1348, 1258, 1145 cm^{-1} ; ^1H NMR (400 MHz, CDCl_3): 7.77 (2H, d, $J = 9.5$ Hz, H-4), 6.91 (2H, d, $J = 8.3$ Hz, H-3), 4.69 (1H, sept, $J = 7.2$ Hz, H-6), 3.76 (3H, s, H-1), 1.39 (6H, d, $J = 7.2$ Hz, H-7), 1.32 (9H, s, H-12); ^{13}C NMR (100 MHz, CDCl_3): 163.1, 150.8, 132.5, 129.7, 113.7, 83.7, 55.6, 51.0, 27.9, 21.3; MS: 353 ($\text{M}+\text{Na}$) $^+$, 330 ($\text{M}+\text{H}$) $^+$, 274 ($\text{M}+\text{H}-\text{C}_4\text{H}_8$) $^+$; HRMS: found ($\text{M}+\text{H}$) $^+$ 330.1368, $\text{C}_{15}\text{H}_{23}\text{NO}_5\text{S}$ requires ($\text{M}+\text{H}$) $^+$ 330.1370.

Tertbutylisopropyl((4-nitrophenyl)sulphonyl)carbamate, 213

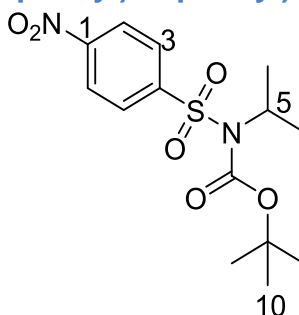

Brown solid (464.7 mg, 74%); mp: 154–156 °C; IR: ν_{max} (ATR): 3107, 2976, 1717, 1528, 1350, 1144, 742 cm^{-1} ; ^1H NMR (400 MHz, CDCl_3): 8.37 (2H, d, $J = 8.6$ Hz, H-2), 8.10 (2H, d, $J = 8.6$ Hz, H-3), 4.77 (1H, sept, $J = 7.0$ Hz, H-5), 1.49 (6H, d, $J = 7.0$ Hz, H-6 or 7), 1.40 (9H, s, H-10); ^{13}C NMR (100 MHz, CDCl_3): 150.4, 150.1, 146.5, 128.9, 123.9, 85.0, 51.9, 27.9, 21.5 ppm; MS: 367 ($\text{M}+\text{Na}$) $^+$; HRMS: found ($\text{M}+\text{Na}$) $^+$ 367.0934, $\text{C}_{14}\text{H}_{20}\text{N}_2\text{O}_6\text{S}$ requires ($\text{M}+\text{Na}$) $^+$ 367.0934.

10.2.12. General synthesis of *N*-acylated compounds

To a solution of pyridine-2-sulfonic acid benzylamide (234 mg, 1 mmol) in THF (10 mL) at 0 °C was added NaH (80 mg, 2 mmol, 60 % dispersion in mineral oil), followed by the appropriate acid chloride (1.2 mmol). The

solution was stirred at room temperature for 1 hr and then quenched with H₂O (5 mL) and extracted with CH₂Cl₂ (2 x 10 mL), dried over sodium sulphate and filtered to give an oil. The crude material was purified by column chromatography (3:1 petrol/EtOAc) to give the acylated product.

Ethylisopropyl(tosyl)carbamate, 205

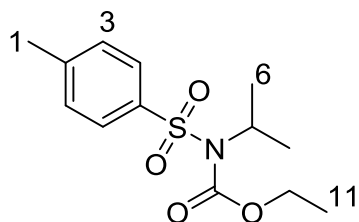

Colourless oil (219.4 mg, 77%); IR: ν_{\max} (ATR) 2921, 2853, 1737, 1460 cm⁻¹; ¹H NMR (400 MHz, CDCl₃): 7.74 (2H, d, J = 8.7 Hz, H-4), 7.22 (2H, d, J = 8.7 Hz, H-3), 4.75 (1H, sept, J = 6.1 Hz, H-6), 4.05 (2H, q, J = 7.9 Hz, H-10), 2.35 (3H, s, H-1), 1.39 (6H, d, J = 6.1 Hz, H-7 or 8), 1.11 (3H, q, J = 7.9 Hz, H-11); ¹³C NMR (100 MHz, CDCl₃): 152.2, 144.1, 137.6, 129.3, 128.0, 62.9, 51.4, 21.6, 21.4, 13.9 ppm; MS: 308 (M+Na)⁺, 286 (M+H)⁺; HRMS: found (M+H)⁺ 286.1109, C₁₃H₁₉NO₄S requires (M+H)⁺ 286.1108.

Methylisopropyl(tosyl)carbamate, 206

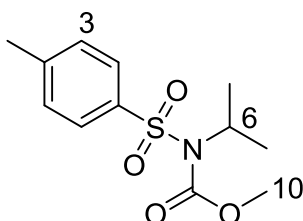

Colourless oil (227.6 mg, 84%); IR: ν_{\max} (ATR) 2975, 1730, 1351, 1256 cm⁻¹; ¹H NMR (400 MHz, CDCl₃) 7.74 (1H, d, J = 8.2 Hz, H-2), 7.24 (1H, d, J = 8.2 Hz, H-3), 4.75 (1H, sept, J = 7.2 Hz, H-6), 3.61 (3H, s, H-10), 2.36 (3H, s, H-12), 1.38 (6H, d, J = 7.2 Hz, H-7 or H-8) ppm; ¹³C NMR (100 MHz, CDCl₃): 152.8, 144.3, 137.4, 129.3, 128.0, 53.2, 51.6, 21.5, 21.3 ppm; MS: 294

(M+Na)⁺, 272 (M+H)⁺; HRMS: found (M+Na)⁺ 294.0771, C₁₂H₁₇NO₄S requires (M+Na)⁺ 294.0770.

Ethylisopropyl(phenylsulphonyl)carbamate, 208

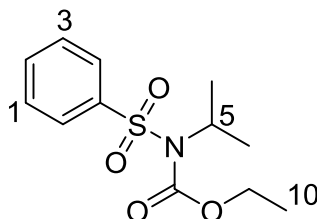

Colourless oil (205.9 mg, 76%); IR: ν_{\max} (ATR) 2936, 1726, 1368, 1350, 1251 cm^{-1} ; ¹H NMR (400 MHz, CDCl₃): 7.94 (2H, d, J = 7.6 Hz, H-3), 7.61 (1H, t, J = 7.6 Hz, H-1), 7.52 (2H, t, J = 7.6 Hz, H-2), 4.85 (1H, sept, J = 6.8 Hz, H-5), 4.12 (2H, q, J = 7.4 Hz, H-9), 1.49 (6H, d, J = 6.8 Hz, H-6 or 7), 1.17 (3H, q, J = 7.4 Hz, H-10); ¹³C NMR (100 MHz, CDCl₃): 152.1, 140.6, 133.2, 128.7, 127.9, 63.0, 51.5, 21.4, 13.9 ppm; MS: 294 (M+Na)⁺, 272 (M+H)⁺; HRMS: found (M+H)⁺ 272.0953, C₁₂H₁₇NO₄S requires (M+H)⁺ 272.0951.

Methylisopropyl(tosyl)carbamate, 209

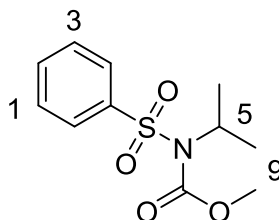

Colourless oil (210.7 mg, 82%); IR: ν_{\max} (ATR) 2975, 1729, 1448, 1353, 1256, 1089 cm^{-1} ; ¹H NMR (400 MHz, CDCl₃): 7.87 (2H, d, J = 7.5 Hz, H-3), 7.54 (1H, t, J = 7.5 Hz, H-1), 7.45 (2H, t, J = 7.5 Hz, H-2), 4.76 (1H, sept, J = 6.9 Hz, H-5), 3.61 (3H, s, H-9), 1.34 (6H, d, J = 6.9 Hz, H-6 or 7) ppm; ¹³C NMR (100 MHz, CDCl₃): 152.8, 140.4, 133.2, 128.7, 127.9, 53.3, 51.7, 29.7,

21.3 ppm; MS: 280 (M+Na)⁺, 258 (M+H)⁺; HRMS: found (M+H)⁺ 258.0796, C₁₁H₁₅NO₄S requires (M+H)⁺ 272.0951

Ethylisopropyl((4-methoxyphenyl)sulphonyl)carbamate, 211

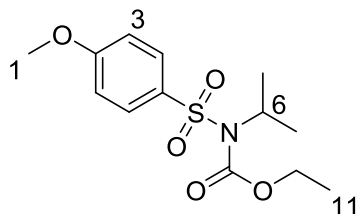

Colourless solid (246.8 mg, 82%); mp: 57–58 °C; IR: ν_{\max} (ATR) 2978, 1724, 1595, 1254, 1087 cm⁻¹; ¹H NMR (400 MHz, CDCl₃): 7.87 (2H, d, *J* = 8.8 Hz, H-4), 6.97 (2H, d, *J* = 8.8 Hz, H-3), 4.81 (1H, sept, *J* = 7.0 Hz, H-6), 4.14 (2H, q, *J* = 7.3 Hz, H-10), 3.87 (3H, s, H-1), 1.46 (6H, d, *J* = 7.3 Hz, H-7 or 8), 1.21 (3H, q, *J* = 7.3 Hz, H-11); ¹³C NMR (100 MHz, CDCl₃): 163.3, 152.2, 132.0, 130.2, 113.8, 62.8, 55.7, 51.4, 21.4, 14.0 ppm; MS: 324 (M+Na)⁺, 302 (M+H)⁺; HRMS: found (M+H)⁺ 302.1057, C₁₃H₁₉NO₅S requires (M+H)⁺ 302.1057.

Methylisopropyl((4-methoxyphenyl)sulphonyl)carbamate, 212

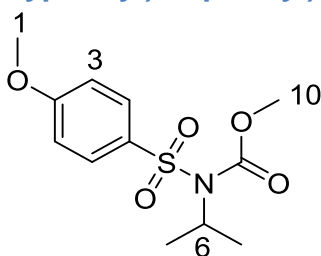

Colourless oil (215.2 mg, 75%); IR: ν_{\max} (ATR) 2975, 1728, 1595, 1350, 1256 cm⁻¹; ¹H NMR (400 MHz, CDCl₃): 7.79 (2H, d, *J* = 8.4 Hz, H-4), 6.90 (2H, d, *J* = 8.4 Hz, H-3), 4.73 (1H, sept, *J* = 7.0 Hz, H-6), 3.79 (3H, s, H-5), 3.61 (3H, s, H-10), 1.36 (6H, d, *J* = 7.0 Hz, H-7 or 8) ppm; ¹³C NMR (100 MHz, CDCl₃): 163.4, 152.8, 131.7, 130.3, 114.1, 55.7, 53.2, 51.5, 23.7 ppm; MS: 310

(M+Na)⁺, 288 (M+H)⁺; HRMS: found (M+Na)⁺ 310.0717, C₁₂H₁₇NO₅S requires (M+Na)⁺ 310.0720

Ethylisopropyl((4-nitrophenyl)sulphonyl)carbamate, 214

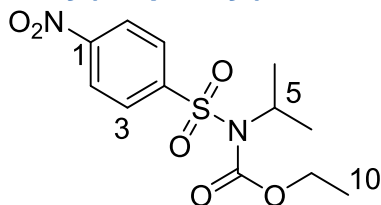

Brown solid (193.1 mg, 68%); mp: 83–84 °C; IR: ν_{\max} (ATR) 3109, 2981, 2926, 1730, 1531, 1345, 1169 cm⁻¹; ¹H NMR (400 MHz, CDCl₃): 8.38 (2H, d, J = 8.7 Hz, H-2), 8.15 (2H, d, J = 8.7 Hz, H-3), 4.85 (1H, sept, J = 6.6 Hz, H-5), 4.18 (2H, q, J = 7.5 Hz, H-9), 1.51 (6H, d, J = 6.6 Hz, H-6 or 7), 1.24 (3H, q, J = 7.5 Hz, H-10) ppm; ¹³C NMR (100 MHz, CDCl₃): 151.0, 146.0, 129.3, 123.9, 68.0, 63.5, 52.2, 25.6, 21.5, 14.0 ppm; MS: 339 (M+Na)⁺; HRMS: found (M+Na)⁺ 339.0620, C₁₂H₁₆N₂O₆S requires (M+Na)⁺ 339.0621.

Methylisopropyl((4-nitrophenyl)sulphonyl)carbamate, 215

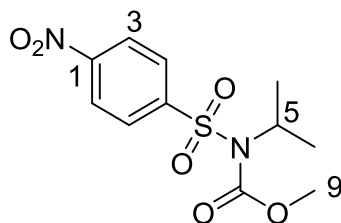

Brown solid (172.8 mg, 64%); mp: 99–100 °C; IR: ν_{\max} (ATR) 2978, 1732, 1532, 1349 cm⁻¹; ¹H NMR (400 MHz, CDCl₃): 8.37 (2H, d, J = 8.6 Hz, H-2), 8.13 (2H, d, J = 8.6 Hz, H-3), 4.83 (1H, sept, J = 7.0 Hz, H-5), 3.72 (3H, s, H-9), 1.48 (6H, d, J = 7.0 Hz, H-6 or 7) ppm; ¹³C NMR (100 MHz, CDCl₃): 152.5, 150.3, 145.7, 129.4, 124.0, 53.7, 52.3, 21.4 ppm; MS: 325 (M+Na)⁺; HRMS: found (M+Na)⁺ 325.0462, C₁₁H₁₄N₂O₆S requires (M+Na)⁺ 325.0465.

10.2.13. General procedure for the rearrangement reaction

To a solution of the boc-protected amine (1 mmol) in THF (2 mL) at -78 °C was added LDA (1M, 1 mL) over 2 minutes. The solution was stirred at -78 °C for 30 minutes and then quenched with citric acid aqueous solution (5 mL) and extracted with CH₂Cl₂ (2 x 10 mL), dried over sodium sulphate and filtered to give the product.

Tertbutyl-2-(N-(1-(tert-butoxy)-3-methyl-1-oxobutan-2-yl)sulphamoyl)-5-methylbenzoate, 194

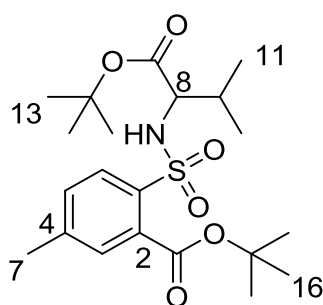

Colourless oil (338.9 mg, 79%); IR: ν_{\max} (ATR) 3292, 2974, 2934, 1718, 1256, 1156, 1137 cm⁻¹; ¹H NMR (400 MHz, CDCl₃): 7.82 (1H, d, *J* = 8.6 Hz, H-6), 7.49 (1H, s, H-3), 7.29 (1H, d, *J* = 8.6 Hz, H-5), 6.46 (1H, d, *J* = 8.6 Hz, NH), 3.79 (1H, dd, *J* = 8.6, 6.4 Hz, H-8), 2.41 (3H, s, H-7), 2.04 (1H, oct, *J* = 6.4 Hz, H-9), 1.64 (9H, H-13 or 16), 1.16 (9H, H-13 or 16), 0.99 (3H, d, *J* = 6.4 Hz, H-14 or 15), 0.94 (3H, d, *J* = 6.4 Hz, H-14 or 15) ppm; ¹³C NMR (100 MHz, CDCl₃): 169.9, 166.7, 142.9, 136.4, 132.7, 131.0, 130.8, 128.8, 83.5, 81.9, 62.6, 31.9, 28.1, 27.6, 21.3, 19.0, 17.7 ppm; MS: 408 (M+Na)⁺; HRMS: found (M+Na)⁺ 408.1452, C₁₈H₂₇NO₆S requires (M+Na)⁺ 408.1451.

Tertbutyl-2-(*N*-isopropylsulphamoyl)-5-methylbenzoate, 216

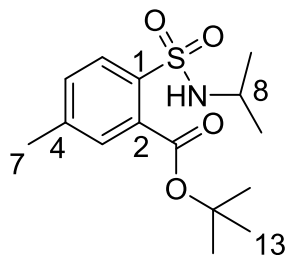

Colourless oil (267.7 mg, 85%); IR: ν_{\max} (ATR) 3294, 2976, 2936, 1706, 1306, 1119 cm^{-1} ; ^1H NMR (400 MHz, CDCl_3): 7.85 (1H, d, $J = 7.8$ Hz, H-6), 7.39 (1H, s, H-3), 7.28 (1H, d, $J = 7.8$ Hz, H-5), 5.62 (1H, d, $J = 6.7$ Hz, NH), 3.42 (1H, oct, $J = 6.7$ Hz, H-8), 2.37 (3H, s, H-7), 1.55 (9H, s, H-13), 1.01 (6H, d, $J = 6.7$ Hz, H-9 or H-10) ppm; ^{13}C NMR (100 MHz, CDCl_3): 167.5, 142.8, 133.3, 132.6, 131.1, 130.7, 83.7, 46.6, 28.0, 23.6, 21.3 ppm; MS: 336 ($\text{M}+\text{Na}$) $^+$, 314 ($\text{M}+\text{H}$) $^+$, 258 ($\text{M}-t\text{Bu}$) $^+$; HRMS: found ($\text{M}+\text{H}$) $^+$ 314.1421, $\text{C}_{15}\text{H}_{23}\text{NO}_4\text{S}$ requires ($\text{M}+\text{Na}$) $^+$ 314.1421.

Ethyl-2-(*N*-isopropylsulphamoyl)-5-methylbenzoate, 217

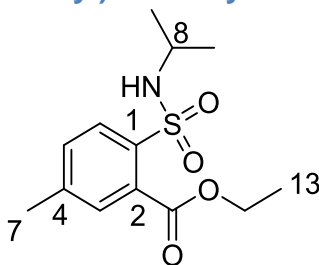

Colourless oil (222.3 mg, 78%); IR: ν_{\max} (ATR) 3300, 2974, 1714, 1338, 1266, 1164, 1117 cm^{-1} ; ^1H NMR (400 MHz, CDCl_3): 7.89 (1H, d, $J = 7.7$ Hz, H-4), 7.52 (1H, d, $J = 1.0$ Hz, H-3), 7.34 (1H, dd, $J = 7.7, 1.0$ Hz, H-7), 5.69 (1H, d, $J = 7.0$ Hz, NH), 4.35 (2H, q, $J = 7.2$ Hz, H-9), 3.42 (1H, oct, $J = 7.0$ Hz, H-8), 2.37 (3H, s, H-7), 1.34 (3H, t, $J = 7.2$ Hz, H-13), 1.00 (6H, d, $J = 7.0$ Hz, H-11) ppm; ^{13}C NMR (100 MHz, CDCl_3): 167.9, 143.0, 137.4, 131.8, 131.2, 129.5, 128.0, 62.4, 46.5, 23.6, 21.4, 14.1 ppm.

Methyl-2-(*N*-isopropylsulphamoyl)-5-methylbenzoate, 218

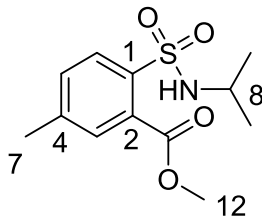

Colourless oil (224.9 mg, 83%); IR: ν_{\max} (ATR) 3299, 2974, 1719, 1435, 1337, 1267, 1163, 1118 cm^{-1} ; ^1H NMR (400 MHz, CDCl_3): 7.91 (1H, d, $J = 8.2\text{Hz}$, H-6), 7.55 (1H, d, $J = 1.6\text{ Hz}$, H-3), 7.34 (1H, dd, $J = 8.2, 1.6\text{ Hz}$, H-5), 5.68 (1H, d, $J = 7.2\text{ Hz}$, NH), 3.89 (3H, s, H-12), 3.43 (1H, oct, $J = 7.2\text{ Hz}$, H-8), 2.38 (3H, s, H-7), 1.00 (6H, d, $J = 7.2\text{ Hz}$, H-9 or 10) ppm; ^{13}C NMR (100 MHz, CDCl_3): 168.2, 143.0, 137.6, 132.0, 131.4, 130.2, 129.6, 53.2, 46.5, 23.6, 21.2 ppm.

tert-butyl-2-(*N*-isopropylsulphamoyl)benzoate, 219

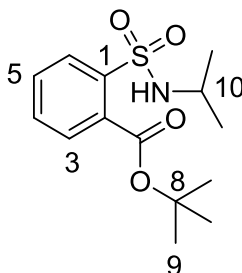

Colourless oil (276.9 mg, 92%); IR: ν_{\max} (ATR) 3291, 2978, 2935, 1706, 1370, 1304, 1119 cm^{-1} ; ^1H NMR (400 MHz, CDCl_3): 7.97 (1H, m, $J = 8.5\text{Hz}$, H-6), 7.62 (1H, m, H-3), 7.52-7.48 (2H, m, H-4 and 5), 5.70 (1H, d, $J = 7.2\text{ Hz}$, NH), 3.43 (1H, oct, $J = 7.2\text{ Hz}$, H-10), 1.54 (9H, s, H-11), 1.00 (6H, d, $J = 7.2\text{ Hz}$, H-9) ppm; ^{13}C NMR (100 MHz, CDCl_3): 167.3, 139.6, 132.9, 132.0, 130.7, 128.6, 127.4, 83.7, 67.9, 46.6, 28.0, 21.4 ppm; MS: 322 ($\text{M}+\text{Na}$) $^+$, 300 ($\text{M}+\text{H}$) $^+$, 244 ($\text{M}-\text{tBu}$) $^+$; HRMS: found ($\text{M}+\text{H}$) $^+$ 300.1274, $\text{C}_{14}\text{H}_{21}\text{NO}_4\text{S}$ requires ($\text{M}+\text{H}$) $^+$ 300.1264.

Ethyl-2-(*N*-isopropylsulphamoyl)benzoate, 220

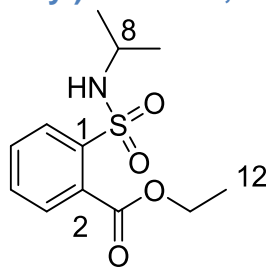

Colourless oil (211.4 mg, 78%); IR: ν_{\max} (ATR) 3297, 2975, 2935, 1713, 1338, 1280, 1166, 1115 cm^{-1} ; ^1H NMR (400 MHz, CDCl_3): 8.03 (1H, m, H-6), 7.73 (1H, m, H-3), 7.56-7.53 (2H, m, H-4 and 5), 5.73 (1H, d, $J = 6.0$ Hz, NH), 4.36 (2H, q, $J = 7.6$ Hz, H-11), 3.45 (1H, m, H-7), 1.34 (3H, t, $J = 7.6$ Hz, H-12), 1.01 (6H, d, $J = 7.6$ Hz, H-8 and 9) ppm; ^{13}C NMR (100 MHz, CDCl_3): 167.8, 140.3, 132.1, 131.5, 130.8, 129.3, 127.4, 62.5, 46.8, 22.2, 14.1 ppm; MS: 294 ($\text{M}+\text{Na}$) $^+$, 272 ($\text{M}+\text{H}$) $^+$; HRMS: found ($\text{M}+\text{H}$) $^+$ 272.0956, $\text{C}_{14}\text{H}_{21}\text{NO}_4\text{S}$ requires ($\text{M}+\text{H}$) $^+$ 300.1264.

Methyl-2-(*N*-isopropylsulphamoyl)benzoate, 221

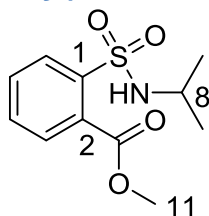

Colourless oil (215.9 mg, 84%); IR: ν_{\max} (ATR) 3296, 2975, 1718, 1289, 1115 cm^{-1} ; ^1H NMR (400 MHz, CDCl_3): 7.99 (1H, dd, $J = 7.5, 2.4$ Hz, H-6), 7.69 (1H, dd, $J = 7.5, 2.4$ Hz, H-3), 7.52-7.48 (2H, m, H-4 and 5), 5.70 (1H, d, $J = 6.4$ Hz, NH), 3.85 (3H, s, H-11), 3.42 (1H, oct, $J = 6.4$ Hz, H-7), 0.97 (6H, d, $J = 6.4$ Hz, H-8 and 9) ppm; ^{13}C NMR (100 MHz, CDCl_3): 168.2, 140.5, 132.1, 131.7, 130.7, 129.1, 127.0, 53.3, 46.6, 23.8 ppm; MS: 280 ($\text{M}+\text{Na}$) $^+$, 258 ($\text{M}+\text{H}$) $^+$; HRMS: found ($\text{M}+\text{H}$) $^+$ 258.0797, $\text{C}_{11}\text{H}_{15}\text{NO}_4\text{S}$ requires ($\text{M}+\text{H}$) $^+$ 258.0795.

Tertbutyl-2-(*N*-isopropylsulphamoyl)-5-methoxybenzoate, 222

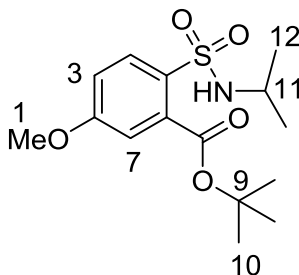

Colourless oil (297.9 mg, 90%); IR: ν_{\max} (ATR) 3298, 2977, 1710, 1594, 1572, 1308, 1163 cm^{-1} ; ^1H NMR (400 MHz, CDCl_3): 7.95 (1H, d, $J = 8.5$ Hz, H-4), 7.13 (1H, d, $J = 2.8$ Hz, H-7), 6.93 (1H, dd, $J = 8.5, 2.8$ Hz, H-3), 5.59 (1H, d, $J = 6.8$ Hz, NH), 3.86 (3H, s, H-1), 3.44 (1H, oct, $J = 6.8$ Hz, H-11), 1.59 (9H, s, H-10), 1.07 (6H, d, $J = 6.8$ Hz, H-12) ppm; ^{13}C NMR (100 MHz, CDCl_3): 167.0, 162.0, 134.4, 131.4, 131.3, 116.7, 114.2, 83.8, 55.8, 46.5, 28.0, 23.6; MS: 352 ($\text{M}+\text{Na}$) $^+$, 330 ($\text{M}+\text{H}$) $^+$, 274 ($\text{M}-t\text{Bu}$) $^+$; HRMS: found ($\text{M}+\text{H}$) $^+$ 330.1367, $\text{C}_{15}\text{H}_{23}\text{NO}_5\text{S}$ requires ($\text{M}+\text{H}$) $^+$ 330.1370.

Ethyl-2-(*N*-isopropylsulphamoyl)-5-methoxybenzoate, 223

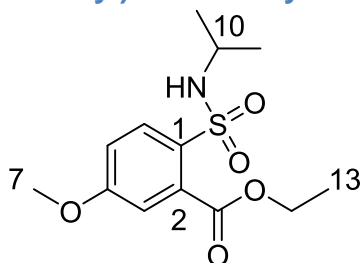

Colourless oil (279.9 mg, 93%); IR: ν_{\max} (ATR) 3302, 2975, 1715, 1571, 1335, 1292, 1113 cm^{-1} ; ^1H NMR (400 MHz, CDCl_3): 7.95 (1H, d, $J = 8.9$ Hz, H-6), 7.20 (1H, d, $J = 2.8$ Hz, H-3), 6.97 (1H, dd, $J = 8.9, 2.8$ Hz, H-5), 5.60 (1H, d, $J = 6.4$ Hz, NH), 4.35 (2H, q, $J = 7.5$ Hz, H-12), 3.83 (3H, s, H-7), 3.42 (1H, oct, $J = 6.4$ Hz, H-8), 1.35 (3H, t, $J = 7.5$ Hz, H-12), 1.02 (6H, d, $J = 6.4$ Hz, H-9 or H-10); ^{13}C NMR (100 MHz, CDCl_3): 167.5, 162.1, 132.5, 131.7, 131.6, 117.0, 115.1, 62.6, 55.9, 46.5, 23.6, 14.1 ppm; MS: 324 ($\text{M}+\text{Na}$) $^+$, 302

(M+H)⁺; HRMS: found (M+H)⁺ 302.1061, C₁₃H₁₉NO₅S requires (M+H)⁺ 302.1061.

Methyl-2-(*N*-isopropylsulphamoyl)-5-methoxybenzoate, 224

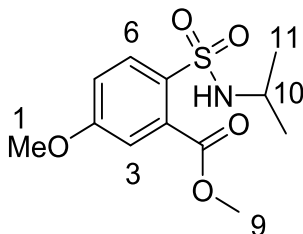

Colourless oil (229.6 mg, 80%); IR: ν_{\max} (ATR) 3299, 2974, 1719, 1435, 1337, 1267, 1163, 1118 cm⁻¹; ¹H NMR (400 MHz, CDCl₃): 7.91 (1H, d, *J* = 8.2 Hz, H-4), 7.55 (1H, d, *J* = 1.6 Hz, H-3), 7.34 (1H, dd, *J* = 8.2, 1.6 Hz, H-7), 5.68 (1H, d, *J* = 7.2 Hz, NH), 3.89 (3H, s, H-9), 3.43 (1H, oct, *J* = 7.2 Hz, H-10), 2.38 (3H, s, H-1), 1.00 (6H, d, *J* = 7.2 Hz, H-11) ppm; ¹³C NMR (100 MHz, CDCl₃): 168.2, 143.0, 137.6, 132.0, 131.4, 130.2, 129.6, 53.2, 46.5, 23.6, 21.2 ppm; MS: 310 (M+Na)⁺, 288 (M+H)⁺; HRMS: found (M+H)⁺ 288.0902, C₁₂H₁₇NO₅S requires (M+H)⁺ 288.0900.

10.2.14. General procedure Sulphonamide derived from *Tert*butyl Aniline

To a solution of aryl sulphonyl chloride (10 mmol) in CH₂Cl₂ (20 mL) was added *tert*butylaniline (10 mmol) and triethylamine (1.6 g, 18 mmol). The resulting solution was stirred for 30 mins at room temperature. The mixture was extracted with CH₂Cl₂ (2 x 10 mL), and washed with 2M HCl (2 x 10 mL) and NaHCO₃ solution. The organic layer was dried over MgSO₄, filtered and the solvent was removed to give the crude sulphonamide. If required, the sulphonamide was further purified by recrystallisation from aqueous EtOH.

***N*-(4-*tert*butylphenyl)-4-methylbenzenesulphonamide, 226**

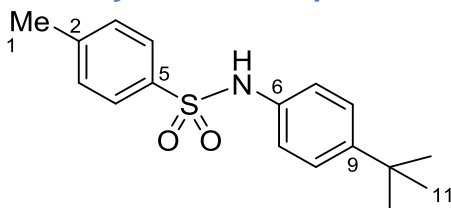

White solid, mp: 170–172 °C; (3.50 g, 84%); IR: ν_{max} (ATR) 3219, 3070, 2969, 1596, 1433, 1323, 1149 cm^{-1} ; ^1H NMR (400 MHz, CDCl_3): 7.89 (2H, d, $J = 8.3$ Hz, H-4), 7.16 (4H, t, $J = 7.4$ Hz, H-3, H-8), 6.90 (2H, d, $J = 6.7$ Hz, H-7), 6.31 (1H, s, N-H) 2.40 (3H, s, H-1) 1.22 (9H, s, H-11); ^{13}C NMR (100 MHz, CDCl_3): 146.8, 141.9, 134.7, 131.8, 127.8, 124.4, 120.0, 32.6, 29.5, 19.6 ppm. MS: 326 ($\text{M}+\text{Na}$) $^+$, 304 ($\text{M}+\text{H}$) $^+$, 248 ($\text{M}+\text{H}-\text{C}_4\text{H}_8$) $^+$.

***N*-(4-*tert*butylphenyl)-4-methoxybenzenesulphonamide, 227**

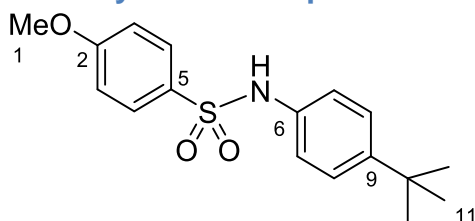

White needle-like crystals (1.69 g, 53 %); mp: 168–169 °C; IR: ν_{max} (ATR) 3231, 3023, 2971, 2956, 1594, 1446, 1267, 1148 cm^{-1} ; ^1H NMR (400 MHz, CDCl_3): 7.73 (2H, d, $J = 8.8$ Hz, H-4), 7.28 (2H, d, $J = 9.0$ Hz, H-8), 6.89 (2H, d, $J = 8.6$ Hz, H-7), 6.91 (2H, d, $J = 8.9$ Hz, H-3), 6.36 (1H, s, N-H), 3.85 (3H, s, H-1), 1.28 (9H, s, H-11); ^{13}C NMR (100 MHz, CDCl_3): 163.0, 148.6, 133.7, 131.0, 129.4, 126.2, 121.8, 114.1, 55.6, 34.4, 31.3 ppm. MS: 342 ($\text{M}+\text{Na}$) $^+$, 320 ($\text{M}+\text{H}$) $^+$, 264 ($\text{M}+\text{H}-\text{C}_4\text{H}_8$) $^+$.

N-(4-*tert*butylphenyl)-4-acetylbenzenesulphonamide, 228

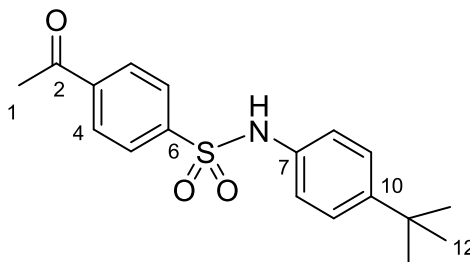

White needle-like crystals (2.87 g, 92%); mp: 104–106 °C; IR: ν_{\max} (ATR) 3257, 2961, 1685, 1594, 1466, 1261, 1160 cm^{-1} ; ^1H NMR (400 MHz, CDCl_3): 8.02 (2H, d, $J = 8.5$ Hz, H-5), 7.87 (2H, d, $J = 8.5$ Hz, H-4), 7.29 (2H, d, $J = 8.6$ Hz, H-9), 6.98 (2H, d, $J = 8.6$ Hz, H-8), 6.49 (1H, s, N-H), 2.65 (3H, s, H-1), 1.28 (9H, s, H-12) ; ^{13}C NMR (100 MHz, CDCl_3): 197.7, 149.4, 143.3, 140.2, 140.0, 128.8, 127.6, 126.5, 122.3, 34.4, 31.2, 26.8 ppm; MS: 354 ($\text{M}+\text{Na}$) $^+$, 304 ($\text{M}+\text{H}$) $^+$, 276 ($\text{M}+\text{H}-\text{C}_4\text{H}_8$) $^+$.

N-(4-*tert*butylphenyl)-4-cyanobenzenesulphonamide, 229

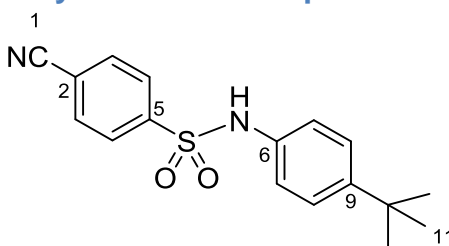

Off white shiny needle-like crystals (2.77 g, 88%); mp: 168–170 °C; IR: ν_{\max} (ATR) 3233, 3039, 2957, 2235, 1594, 1382, 1165 cm^{-1} ; ^1H NMR (400 MHz, CDCl_3): 7.76 (2H, d, $J = 8.42$, H-4), 7.68 (2H, d, $J = 8.43$, H-3) 7.22 (2H, d, $J = 8.62$, H-8) 6.91 (2H, d, $J = 8.6$ Hz, H-7) 6.37 (1H, s, N-H), 1.20 (9H, s, H-11); ^{13}C NMR (100 MHz, CDCl_3): 154.6, 143.1, 133.0, 130.6, 130.4, 129.3, 126.8, 117.9, 117.0, 35.0, 31.2 ppm.

N-(4-*tert*butylphenyl)-4-fluorobenzenesulphonamide, 230

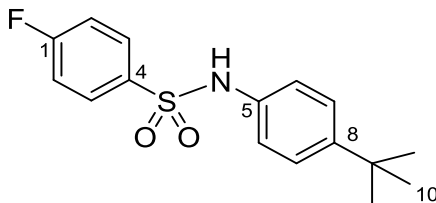

White crystalline solid (2.57 g, 93%); mp: 160–162 °C; IR: ν_{\max} (ATR) 3246, 3066, 2962, 2867, 1590, 1458, 1236, 1167 cm^{-1} ; ^1H NMR (400 MHz, CDCl_3): 7.80 (2H, m, H-3), 7.28 (2H, t, $J = 7.5$ Hz, H-2) 7.13 (2H, m, H-7) 7.28 (2H, t, $J = 7.5$ Hz, H-6) 7.13 (2H, t, $J = 8.5$ Hz, H-8), 6.99 (2H, d, $J = 8.6$ Hz, H-6) 6.61 (1H, s, N-H), 1.28 (9H, s, H-10); ^{13}C NMR (100 MHz, CDCl_3): 149.2, 133.2, 130.0, 129.9, 126.3, 122.2, 116.4, 116.1, 34.4, 31.3 ppm.

N-(4-*tert*butylphenyl)-4-chlorobenzenesulphonamide, 231

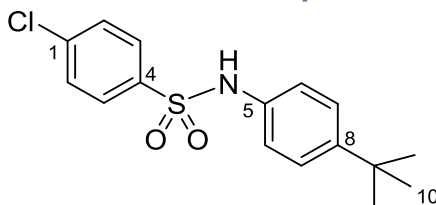

White sandy-like crystals (3.26 g, 91%); mp: 183–185 °C; IR: ν_{\max} (ATR) 3216, 3085, 2958, 2868, 1573, 1476, 1364, 1166, 753 cm^{-1} ; ^1H NMR (400 MHz, CDCl_3): 7.71 (2H, d, $J = 10.8$ Hz, H-3) 7.44 (2H, d, $J = 10.9$ Hz, H-2) 7.29 (2H, d, $J = 11.1$ Hz, H-7), 6.99 (2H, d, $J = 11.2$ Hz, H-6), 6.49 (1H, s, N-H) 1.22 (9H, s, H-10); ^{13}C NMR (100 MHz, CDCl_3): 149.2, 139.5, 137.7, 133.1, 129.3, 128.7, 126.4, 122.1, 34.7, 31.3 ppm. MS: 346 ($\text{M}+\text{Na}$) $^+$, 324 ($\text{M}+\text{H}$) $^+$, 268 ($\text{M}+\text{H}-\text{C}_4\text{H}_8$) $^+$.

N-(4-*tert*butylphenyl)-4-bromobenzenesulphonamide, 232

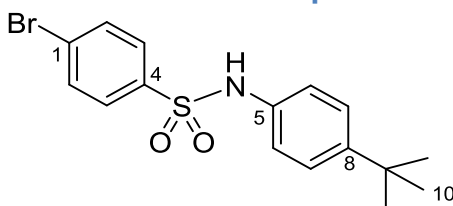

White crystals (2.96 g, 81%); mp: 188–191 °C; IR: ν_{\max} (ATR) 3218, 3051, 2968, 1576, 1327, 1150, 746 cm^{-1} ; ^1H NMR (400 MHz, CDCl_3) 7.53 (4H, q, $J = 7.7$ Hz, H-2, H-3) 7.19 (2H, d, $J = 8.3$ Hz, H-7) 6.89 (2H, d, $J = 8.6$ Hz, H-6) 6.44 (1H, s, N-H) 1.20 (9H, s, H-10) ppm; ^{13}C NMR (100 MHz, CDCl_3): 149.2, 138.3, 133.1, 132.3, 128.8, 128.0, 126.4, 122.1, 34.5, 31.3 ppm. MS: 390 ($\text{M}+\text{Na}$)⁺, 368 ($\text{M}+\text{H}$)⁺, 312 ($\text{M}+\text{H}-\text{C}_4\text{H}_8$)⁺.

10.2.15. General procedure for preparing Carbamates derived from *Tert*butyl Aniline

To a solution of sulphonamide (2 mmol) in THF (20 mL) at 0 °C was added NaH (300 mg, 12.5 mmol, 60% dispersion in mineral oil), followed by the MeOCOCCl (0.5 mL, 6.5 mmol). The solution was stirred at room temperature overnight. The reaction mixture was quenched with water and the organic layer was washed with NaHCO_3 solution. The organic layer was collected, dried over sodium sulphate, filtered and the solvent was removed under reduced pressure to give the crude product. The crude sulphonamide was purified by recrystallisation from aq. EtOH.

Methyl(4-*tert*butylphenyl)[(4-methylphenyl)sulphonyl] carbamate, 233

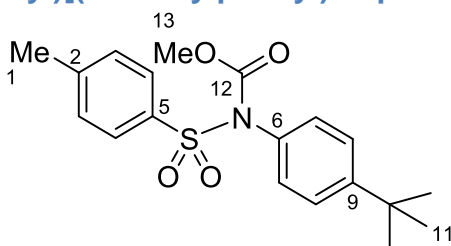

White solid (2.76 g, 96%); 171–173 °C; IR: ν_{\max} (ATR) 3047, 2961, 2871, 1736, 1596, 1436, 1363, 1169 cm^{-1} ; ^1H NMR (400MHz, CDCl_3): 7.85 (2H, d, $J = 8.3$ Hz, H-4), 7.37 (2H, d, $J = 6.6$ Hz, H-8), 7.29 (2H, d, $J = 8.2$ Hz, H-3), 7.18 (2H, d, $J = 6.6$ Hz, H-7) 3.58 (3H, s, H-13) 2.39 (3H, s, H-1), 1.28 (9H, s,

H-11) ppm; ^{13}C NMR (100 MHz, CDCl_3): 152.9, 152.4, 144.8, 136.2, 133.2, 129.5, 129.0, 128.9, 126.3, 53.9, 35.0, 31.3 ppm. MS: 384 ($\text{M}+\text{Na}$) $^+$, 362 ($\text{M}+\text{H}$) $^+$, 306 ($\text{M}+\text{H}-\text{C}_4\text{H}_8$) $^+$.

Methyl(4-*tert*butylphenyl)[(4-methoxyphenyl)sulphonyl] carbamate, 234

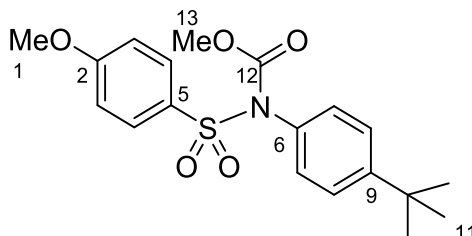

White solid (0.70 g, 93%); mp: 180–182 °C; IR: ν_{max} (ATR) 3032, 2959, 1734, 1593, 1437, 1363, 1163 cm^{-1} ; ^1H NMR (400 MHz, CDCl_3): 7.90 (2H, d, $J = 9.0$ Hz, H-4) 7.35 (2H, d, $J = 8.5$ Hz, H-8) 7.07 (2H, d, $J = 8.5$ Hz, H-7) 6.95 (2H, d, $J = 9.0$ Hz, H-3), 3.83 (3H, s, H-1), 3.58 (3H, s, H-13), 1.27 (9H, s, H-11); ^{13}C NMR (100 MHz, CDCl_3): 163.8, 153.0, 152.3, 133.2, 131.3, 130.6, 128.9, 126.3, 114.0, 56.0, 54.0, 34.8, 31.3 ppm MS: 400 ($\text{M}+\text{Na}$) $^+$, 378 ($\text{M}+\text{H}$) $^+$.

Methyl(4-*tert*butylphenyl)[(4-acetylphenyl)sulphonyl] carbamate, 235

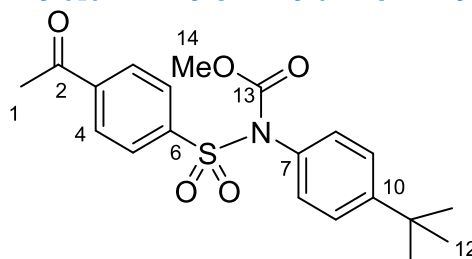

White solid (0.17 g, 44%); mp: 208–210 °C; IR: ν_{max} (ATR) 3046, 2965, 1739, 1639, 1371, 1172 cm^{-1} ; ^1H NMR (400 MHz, CDCl_3): 8.09-8.03 (4H, m, H-3, H-4, 5), 7.39 (2H, d, $J = 8.5$ Hz, H-9), 7.06 (2H, d, $J = 8.5$ Hz, H-8), 3.58 (3H, s, H-14), 2.60 (3H, s, H-1), 1.28 (9H, s, H-12); ^{13}C NMR (100 MHz, CDCl_3): 196.7, 152.8, 142.7, 140.8, 132.7, 129.4, 128.9, 128.6, 126.4, 54.2, 34.8, 31.3, 26.9; MS: 412 ($\text{M}+\text{Na}$) $^+$, 390 ($\text{M}+\text{H}$) $^+$.

Methyl(4-*tert*butylphenyl)[(4-cyanophenyl)sulphonyl] carbamate, 236

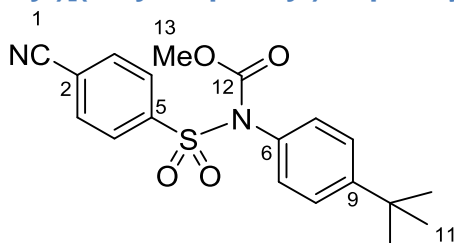

White crystalline solid (0.15 g, 41%); mp: 190–191 °C; IR: ν_{max} (ATR) 3047, 2954, 2870, 2236, 1736, 1508, 1435, 1370, 1187 cm^{-1} ; ^1H NMR (400 MHz, CDCl_3): 8.09 (2H, d, $J = 8.3$ Hz, H-4), 7.80 (2H, d, $J = 8.3$ Hz, H-3), 7.39 (2H, d, $J = 8.5$ Hz, H-8), 7.06 (2H, d, $J = 8.4$ Hz, H-7), 3.59 (3H, s, H-13), 1.18 (9H, s, H-11) ppm; ^{13}C NMR (100 MHz, CDCl_3): 153.0, 152.7, 143.0, 132.5, 132.3, 129.7, 129.7, 128.7, 126.5, 117.4, 54.3, 34.8, 31.2 ppm.

Methyl(4-*tert*butylphenyl)[(4-fluorophenyl)sulphonyl] carbamate, 237

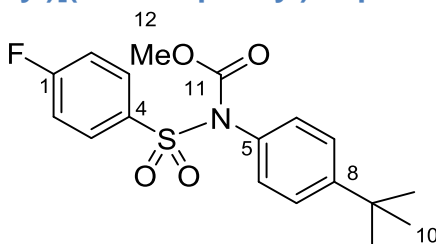

White crystalline solid (0.63 g, 93%); mp: 154–156 °C; IR: ν_{max} (ATR) 3068, 2965, 1736, 1598, 1436, 1369, 1179 cm^{-1} ; ^1H NMR (400 MHz, CDCl_3): 8.08 (2H, m, H-3), 7.46 (2H, d, $J = 8.5$ Hz, H-2), 7.25 (2H, d, $J = 8.5$ Hz, H-7), 7.14 (2H, d, $J = 8.5$ Hz, H-6), 3.68 (3H, s, H-12), 1.39 (9H, s, H-10) ppm; ^{13}C NMR (100 MHz, CDCl_3): 156.9, 151.6, 135.1, 132.9, 131.9, 128.8, 126.3, 116.2 ppm.

Methyl(4-*tert*butylphenyl)[(4-chlorophenyl)sulphonyl]carbamate, 238

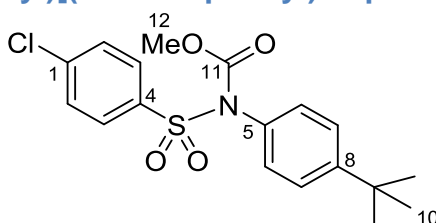

Pale yellow solid (0.30 g, 36%); 174–177 °C; IR: ν_{max} (ATR) 3071, 2960, 2872, 1736, 1584, 1436, 1372, 1182 cm^{-1} ; ^1H NMR (400 MHz, CDCl_3): 7.91 (2H, d, $J = 8.7$ Hz, H-3), 7.47 (2H, d, $J = 8.6$ Hz, H-2), 7.37 (2H, d, $J = 8.5$ Hz, H-7), 7.06 (2H, d, $J = 8.5$ Hz, H-6), 3.59 (3H, s, H-12), 1.18 (9H, s, H-10) ppm; ^{13}C NMR (100 MHz, CDCl_3): 155.6, 148.8, 140.1, 136.0, 130.4, 128.3, 128.1, 125.8, 124.2, 50.8, 35.8, 31.2 ppm; MS: 404 ($\text{M}+\text{Na}$) $^+$, 382 ($\text{M}+\text{H}$) $^+$, 326 ($\text{M}+\text{H}-\text{C}_4\text{H}_8$) $^+$.

Methyl(4-tertbutylphenyl)[(4-bromophenyl)sulphonyl] carbamate, 239

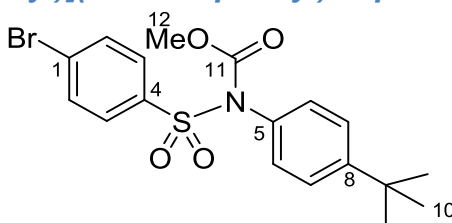

White crystalline solid (0.65 g, 76%); mp: 183–185 °C; IR: ν_{max} (ATR) 3083, 2967, 1736, 1572, 1235, 1173, 742 cm^{-1} ; ^1H NMR (400 MHz, CDCl_3): 7.83 (2H, d, $J = 8.6$ Hz, H-3); 7.65 (2H, d, $J = 8.5$ Hz, H-2), 7.37 (2H, d, $J = 8.5$ Hz, H-7), 7.05 (2H, d, $J = 8.6$ Hz, H-6), 3.58 (3H, s, H-12), 1.27 (9H, s, H-10) ppm; ^{13}C NMR (100 MHz, CDCl_3): 152.7, 138.0, 132.8, 132.2, 130.6, 129.2, 128.8, 126.4, 54.2, 34.8, 31.3 ppm.

10.2.16. General procedure for synthesis of the Rearranged Product

To a solution of the carbamate (0.25 mmol) in THF (1 mL) at -78 °C was added LDA (1M, 1 mL). The solution was stirred at -78 °C for 10 minutes and then quenched with citric acid aqueous solution (2 mL) and extracted with CH_2Cl_2 (2 x 5 mL), dried over sodium sulphate and filtered to give the product. The crude rearranged product was purified by column chromatography (petrol/EtOAc) to give the title compound.

Methyl-2-[(4-*tert*butylphenylsulphamyl]-5-methylbenzoate, 240

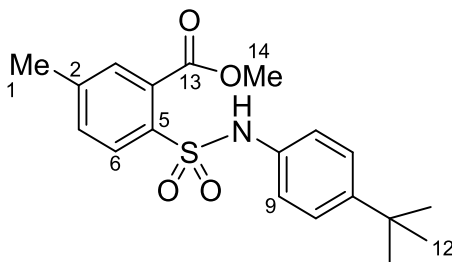

White crystalline solid (70 mg, 78%); mp: 140–143 °C; IR: ν_{max} (ATR) 3273, 3047, 2961, 1734, 1595, 1264, 1156 cm^{-1} ; ^1H NMR (400 MHz, CDCl_3): 7.83 (1H, s, H-3), 7.63 (1H, d, $J = 8.1$ Hz, H-6), 7.54 (1H, s, N-H), 7.14 (3H, m, H-7, H-10), 7.09 (2H, m, H-9), 3.95 (3H, m, H-14), 1.16 (9H, s, H-12) ppm; ^{13}C NMR (100 MHz, CDCl_3): 168.4, 148.7, 143.4, 134.0, 130.6, 129.6, 128.7, 128.3, 126.0, 121.7, 53.5, 40.9, 34.6, 33.8 ppm; MS: 384 ($\text{M}+\text{Na}$) $^+$, 362 ($\text{M}+\text{H}$) $^+$.

Methyl-2-[(4-*tert*butylphenylsulphamyl]-5-methoxybenzoate, 241

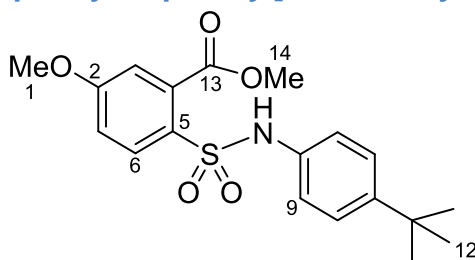

White crystalline solid (90 mg, 95%); mp: 132–134 °C; IR: ν_{max} (ATR) 3305, 3032, 2970, 2873, 1717, 1597, 1497, 1304, 1163, 701 cm^{-1} ; ^1H NMR (400 MHz, CDCl_3): 7.70 (1H, s, N-H), 7.67 (1H, d, $J = 8.8$ Hz, H-6), 7.16 (2H, m, H-10), 6.98 (2H, d, $J = 8.5$ Hz, H-9), 6.70 (1H, dd, $J = 8.8, 2.7$ Hz, H-3), 3.96 (3H, s, H-1), 3.74 (3H, s, H-14), 1.18 (9H, s, H-12) ppm; ^{13}C NMR (100 MHz, CDCl_3): 168.0, 162.8, 148.7, 134.2, 133.6, 131.9, 126.0, 122.7, 116.9, 115.2 ppm.

Methyl-2-[(4-*tert*butylphenylsulphamyl]-5-fluorobenzoate, 243

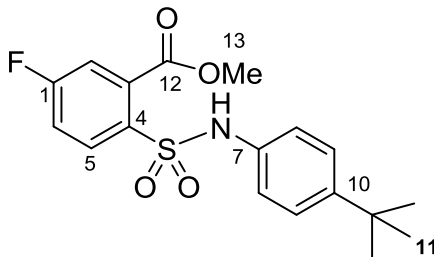

Colourless oil (90.5 mg, 98%); IR: ν_{\max} (ATR) 3285, 3079, 2961, 2869, 1722, 1582, 1437, 1263, 1164, 670 cm^{-1} ; ^1H NMR (400 MHz, CDCl_3): 7.78 (1H, s, N-H), 7.76 (1H, dd, $J = 8.8, 5.6$ Hz, H-2), 7.44 (1H, dd, $J = 8.5, 2.6$ Hz, H-5), 7.16 (2H, m, H-9), 7.06 (1H, m, H-6), 6.99 (2H, m, H-8), 4.00 (3H, s, H-13), 1.19 (9H, s, H-11) ppm; ^{13}C NMR (100 MHz, CDCl_3): 169.2, 162.0, 161.5, 161.3, 161.1, 148.1, 133.5, 129.0, 128.9, 127.9, 122.3, 121.9, 121.0, 117.4 ppm.

Methyl-2-[(4-*tert*butylphenylsulphamyl]-5-chlorobenzoate, 244

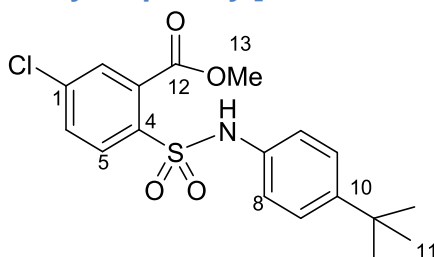

Yellow solid (70 mg, 73%); mp: 106–108 $^{\circ}\text{C}$; IR: ν_{\max} (ATR) 3273, 3020, 2963, 2873, 1718, 1561, 1267, 1165, 705, 670 cm^{-1} ; ^1H NMR (400 MHz, CDCl_3): 7.75 (1H, s, H-2), 7.73–7.67 (2H, m, N-H, H-5), 7.36 (1H, dd, $J = 8.5, 2.1$ Hz, H-6), 7.17 (2H, d, $J = 8.6$ Hz, H-9), 6.98 (2H, d, $J = 8.6$ Hz, H-8), 3.97 (3H, s, H-13), 1.18 (9H, s, H-11) ppm; ^{13}C NMR (100 MHz, CDCl_3): 169.3, 149.2, 139.1, 136.9, 133.5, 131.9, 131.8, 130.7, 129.1, 122.7, 53.8, 34.4, 31.2 ppm; MS: 404 ($\text{M}+\text{Na}$) $^+$, 382 ($\text{M}+\text{H}$) $^+$, 306 ($\text{M}+\text{H}-\text{C}_4\text{H}_8$) $^+$.

Methyl-2-[(4-*tert*butylphenylsulphamyl]-5-methylbenzoate, 245

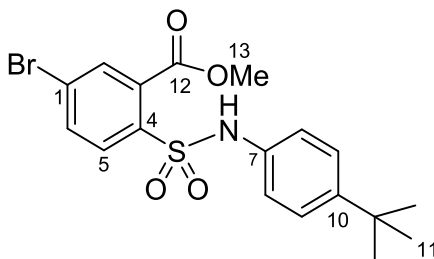

White solid (80.3 mg, 75%); mp: 112–114 °C; IR: ν_{\max} (ATR) 3281, 3061, 2961, 2868, 1718, 1662, 1436, 1288, 1167, 734 cm^{-1} ; ^1H NMR (400 MHz, CDCl_3): 7.96 (1H, s, H-2), 7.86 (1H, s, N-H), 7.66 (1H, m, H-5), 7.27 (2H, d, J = 8.5 Hz, H-9), 7.06 (2H, d, J = 8.5 Hz, H-8), 4.06 (3H, s, H-13), 1.28 (9H, s, H-12) ppm; ^{13}C NMR (100 MHz, CDCl_3): 167.0, 149.2, 137.5, 134.4, 133.5, 132.0, 131.9, 127.2, 126.2, 122.8 ppm; MS: 464 ($\text{M}+\text{K}$) $^+$, 448 ($\text{M}+\text{Na}$) $^+$, 426 (MH^+), 370 ($\text{M}+\text{H}-\text{C}_4\text{H}_8$) $^+$.

11. References

1. Varnali, T.; Edwards, H. G. M., Raman spectroscopic identification of scytonemin and its derivatives as key biomarkers in stressed environments. *Philosophical Transactions of the Royal Society, A: Mathematical, Physical & Engineering Sciences* **2014**, 372, 20140197.
2. Varnali, T.; Edwards, H. G. M., Theoretical Study of Novel Complexed Structures for Methoxy Derivatives of Scytonemin: Potential Biomarkers in Iron-Rich Stressed Environments. *Astrobiology* **2013**, 13, 861-869.
3. Varnali, T.; Edwards, H. G. M., Scytonin, a novel cyanobacterial photoprotective pigment: calculations of Raman spectroscopic biosignatures. *Journal of Molecular Modeling* **2014**, 20, 1-8.
4. Varnali, T.; Edwards, H. G. M., Reduced and oxidised scytonemin: Theoretical protocol for Raman spectroscopic identification of potential key biomolecules for astrobiology. *Spectrochimica Acta, Part A: Molecular and Biomolecular Spectroscopy* **2014**, 117, 72-77.
5. Fulton, J. M.; Arthur, M. A.; Freeman, K. H., Subboreal aridity and scytonemin in the Holocene Black Sea. *Organic Geochemistry* **2012**, 49, 47-55.
6. Wang, G.; Hao, Z.; Huang, Z.; Chen, L.; Li, X.; Hu, C.; Liu, Y., Raman spectroscopic analysis of a desert cyanobacterium *nostoc* sp. in response to UVB radiation. *Astrobiology* **2010**, 10, 783-788.
7. Varnali, T.; Edwards, H. G. M., Ab initio calculations of scytonemin derivatives of relevance to extremophile characterization by Raman spectroscopy. *Philosophical Transactions of the Royal Society, A:*

- Mathematical, Physical & Engineering Sciences* **2010**, 368, 3193-3203.
8. Edwards, H. G. M.; Moody, C. D.; Newton, E. M.; Villar, S. E. J.; Russell, M. J., Raman spectroscopic analysis of cyanobacterial colonization of hydromagnesite, a putative Martian extremophile. *Icarus* **2005**, 175, 372-381.
 9. Gernaey, A. M.; Thomas, A. D.; Foott, L.; Podmore, I. D., Biomarker for cyanobacteria. *Abstracts of Papers, 225th ACS National Meeting, New Orleans, LA, United States, March 23-27, 2003* **2003**, GEOC-153.
 10. Kochanowska-Karamyan, A. J.; Hamann, M. T., Marine Indole Alkaloids: Potential New Drug Leads for the Control of Depression and Anxiety. *Chemical Reviews (Washington, DC, United States)* **2010**, 110, 4489-4497.
 11. Finefield, J. M.; Frisvad, J. C.; Sherman, D. H.; Williams, R. M., Fungal origins of the bicyclo[2.2.2]diazaoctane ring system of prenylated indole alkaloids. *Journal of Natural Products* **2012**, 75, 812-833.
 12. Chakravarti, R. N., Strychnine alkaloids. I. *Journal of the Institution of Chemists (India)* **1968**, 40, 42-8.
 13. Cannon, J. S.; Overman, L. E., Is There No End to the Total Syntheses of Strychnine? Lessons Learned in Strategy and Tactics in Total Synthesis. *Angewandte Chemie, International Edition* **2012**, 51, 4288-4311.

14. Robinson, O. J.; Sahakian, B. J., A Double Dissociation in the Roles of Serotonin and Mood in Healthy Subjects. *Biological Psychiatry* **2009**, *65*, 89-92.
15. Humphrey, G. R.; Kueth, J. T., Practical methodologies for the synthesis of Indoles. *Chemical Reviews (Washington, DC, United States)* **2006**, *106*, 2875-2911.
16. Robinson, B., Fischer indole synthesis. *Chem. Rev.* **1963**, 373-401.
17. Stenske, A., Aromatic benzenoids. Part 3. Reactions of aromatic compounds. *Schweizerische Laboratoriums-Zeitschrift* **2001**, *58*, 184-188.
18. Taylor, R., Electrophilic reactions [of aromatic compounds]. *Int. Rev. Sci. Org. Chem., Ser. Two* **1976**, *3*, 25-61.
19. Laarhoven, W. H.; Nivard, R. J. F., Photochemical reactions of aromatic compounds. *Int. Rev. Sci. Org. Chem., Ser. Two* **1976**, *3*, 125-67.
20. Gangadhararao, G.; Uruvakilli, A.; Swamy, K. C. K., Bronsted Acid Mediated Alkenylation and Copper-Catalyzed Aerobic Oxidative Ring Expansion/Intramolecular Electrophilic Substitution of Indoles with Propargyl Alcohols: A Novel One-Pot Approach to Cyclopenta[c]quinolines. *Organic Letters* **2014**, *16*, 6060-6063.
21. De Rosa, M.; Cuenca, A.; Fernandez, M. R., A new mechanism (SEi) for electrophilic substitution in indoles. Chlorination of indoles with sodium hypochlorite by competitive SE₂ and SE_i mechanisms. *Heterocycles* **1986**, *24*, 1311-18.

22. Islam, M. S.; Al Majid, A. M. A.; Al-Othman, Z. A.; Barakat, A., Highly enantioselective Friedel-Crafts alkylation of indole with electron deficient trans- β -nitroalkenes using Zn(II)-oxazoline-imidazoline catalysts. *Tetrahedron: Asymmetry* **2014**, *25*, 245-251.
23. Bachu, P.; Akiyama, T., Enantioselective Friedel-Crafts alkylation reaction of indoles with α,β -unsaturated acyl phosphonates catalyzed by chiral phosphoric acid. *Chemical Communications (Cambridge, United Kingdom)* **2010**, *46*, 4112-4114.
24. Sundberg, R. J., Electrophilic substitution reactions of indoles. *Topics in Heterocyclic Chemistry* **2010**, *26*, 47-115.
25. Iqbal, Z.; Jackson, A. H.; Rao, K. R. N., Reactions on solid supports. Part IV: reactions of α,β -unsaturated carbonyl compounds with indoles using clay as a catalyst. *Tetrahedron Letters* **1988**, *29*, 2577-80.
26. Berti, G.; Da Settimo, A.; Nannipieri, E., Reactions of some indole derivatives with benzoyl nitrate. Novel oxidative coupling reactions of 2-methylindoles. *Journal of the Chemical Society [Section] C: Organic* **1968**, 2145-51.
27. Yap, W. S.; Gan, C. Y.; Sim, K. S.; Lim, S. H.; Low, Y. Y.; Kam, T.-S., Aspidofractinine and Eburnane Alkaloids from a North Borneo Kopsia. Ring-Contracted, Additional Ring-Fused, and Paucidactine-Type Aspidofractinine Alkaloids from *K. pauciflora*. *Journal of Natural Products* **2016**, *79*, 230-239.
28. Sim, D. S. Y.; Teoh, W. Y.; Sim, K. S.; Lim, S. H.; Thomas, N. F.; Low, Y. Y.; Kam, T.-S., Vobatensines A-F, Cytotoxic Iboga-Vobasine

- Bisindoles from *Tabernaemontana corymbosa*. *Journal of Natural Products* **2016**, *79*, 1048-1055.
29. Nge, C. E.; Chong, K. W.; Thomas, N. F.; Lim, S. H.; Low, Y. Y.; Kam, T. S., Ibogan, aspidosperman, vincamine, and bisindole alkaloids from a Malayan *Tabernaemontana corymbosa*: Iboga alkaloids with C-20 α substitution. *Journal of Natural Products* **2016**, *79*, 1388-1399.
30. Lewis, S. E., Recent advances in the chemistry of macroline, sarpagine and ajmaline-related indole alkaloids. *Tetrahedron* **2006**, *62*, 8655-8681.
31. Dillon, J. G.; Castenholz, R. W., Scytonemin, a cyanobacterial sheath pigment, protects against UVC radiation: implications for early photosynthetic life. *Journal of Phycology* **1999**, *35*, 673-681.
32. Patel, O. P. S.; Mishra, A.; Maurya, R.; Saini, D.; Pandey, J.; Taneja, I.; Raju, K. S. R.; Kanojiya, S.; Shukla, S. K.; Srivastava, M. N.; Wahajuddin, M.; Tamrakar, A. K.; Srivastava, A. K.; Yadav, P. P., Naturally Occurring Carbazole Alkaloids from *Murraya koenigii* as Potential Antidiabetic Agents. *Journal of Natural Products* **2016**, *79*, 1276-1284.
33. Kwon, J.; Seo, Y. H.; Lee, J. E.; Seo, E. K.; Li, S.; Guo, Y.; Hong, S.-B.; Park, S. Y.; Lee, D., Spiroindole alkaloids and spiroditerpenoids from *Aspergillus duricaulis* and their potential neuroprotective effects. *Journal of Natural Products* **2015**, *78*, 2572-2579.
34. Bodur, E.; Cokugras, A. N., The effects of indole-3-acetic acid on human and horse serum butyrylcholinesterase. *Chem Biol Interact* **2005**, *157-158*, 375-8.

35. Yurekli, F.; Geckil, H.; Topcuoglu, F., The synthesis of indole-3-acetic acid by the industrially important white-rot fungus *Lentinus sajor-caju* under different culture conditions. *Mycol. Res.* **2003**, *107*, 305-309.
36. Kutz, A.; Muller, A.; Hennig, P.; Kaiser Werner, M.; Piotrowski, M.; Weiler Elmar, W., A role for nitrilase 3 in the regulation of root morphology in sulphur-starving *Arabidopsis thaliana*. *Plant J* **2002**, *30*, 95-106.
37. Russo, P.; Frustaci, A.; Del Bufalo, A.; Fini, M.; Cesario, A., Multitarget drugs of plants origin acting on Alzheimer's disease. *Current Medicinal Chemistry* **2013**, *20*, 1686-1693.
38. Wilde, M. I.; Markham, A., Ondansetron: A review of its pharmacology and preliminary clinical findings in novel applications. *Drugs* **1996**, *52*, 773-794.
39. Jokela, R. M.; Cakmakkaya, O. S.; Danzeisen, O.; Korttila, K. T.; Kranke, P.; Malhotra, A.; Paura, A.; Radke, O. C.; Sessler, D. I.; Soikkeli, A.; Roewer, N.; Apfel, C. C., Ondansetron has similar clinical efficacy against both nausea and vomiting. *Anaesthesia* **2009**, *64*, 147-151.
40. Fumoleau, P.; Giovannini, M.; Rolland, F.; Votan, B.; Paillarse, J. M.; The French Ondansetron Study, G., Ondansetron suppository: an effective treatment for the prevention of emetic disorders induced by cisplatin-based chemotherapy. *Oral Oncol.* **1997**, *33*, 354-358.
41. Einarson, A.; Maltepe, C.; Navioz, Y.; Kennedy, D.; Tan, M. P.; Koren, G., The safety of ondansetron for nausea and vomiting of pregnancy: a prospective comparative study. *Bjog* **2004**, *111*, 940-942.

42. White, R. H., Indole-3-acetic acid and 2-(indol-3-ylmethyl)indol-3-yl acetic acid in the thermophilic archaebacterium *Sulfolobus acidocaldarius*. *J Bacteriol* **1987**, *169*, 5859-60.
43. Van Order, R. B.; Lindwall, H. G., Indole. *Chem. Rev.* **1942**, *30*, 69-96.
44. Neisewander, J. L.; Cheung, T. H. C.; Pentkowski, N. S., Dopamine D3 and 5-HT1B receptor dysregulation as a result of psychostimulant intake and forced abstinence: Implications for medications development. *Neuropharmacology* **2014**, *76*, 301-319.
45. Haleem, D. J., Serotonin neurotransmission in anorexia nervosa. *Behavioural Pharmacology* **2012**, *23*, 478-495.
46. Ioerger, T. R.; Du, C.; Linthicum, D. S., Conservation of cys-cys trp structural triads and their geometry in the protein domains of immunoglobulin superfamily members. *Molecular immunology* **1999**, *36*, 373-86.
47. Fukuwatari, T.; Shibata, K., Nutritional aspect of tryptophan metabolism. *International Journal of Tryptophan Research* **2013**, *6*, 3-8.
48. Ellinger, P.; Abdel Kader, M. M., Role of tryptophan in the biosynthesis of nicotinamide. *Nature* **1949**, *163*, 799.
49. Marioni, F.; Bertoli, A.; Pistelli, L., A straightforward procedure to biosynthesis melatonin using freshly chopped *Achillea millefolium* L. as reagent. *Phytochemistry Letters* **2008**, *1*, 107-110.
50. Anisimov, V. N., Pineal gland and melatonin. *Melatonin v Norme i Patologii* **2004**, 7-19.

51. Balskus, E. P.; Case, R. J.; Walsh, C. T., The biosynthesis of cyanobacterial sunscreen scytonemin in intertidal microbial mat communities. *FEMS Microbiology Ecology* **2011**, *77*, 322-332.
52. Hickman, A. B.; Klein, D. C.; Dyda, F., Melatonin biosynthesis: the structure of serotonin N-acetyltransferase at 2.5 Å resolution suggests a catalytic mechanism. *Molecular Cell* **1999**, *3*, 23-32.
53. Schomerus, C.; Korf, H. W., Mechanisms regulating melatonin synthesis in the mammalian pineal organ. *Annals of the New York Academy of Sciences* **2005**, *1057*, 372-383.
54. Strasser, B.; Gostner, J. M.; Fuchs, D., Mood, food, and cognition: role of tryptophan and serotonin. *Current Opinion in Clinical Nutrition and Metabolic Care* **2016**, *19*, 55-61.
55. Winge, I.; McKinney, J.; Haavik, J., Tryptophan hydroxylase. *Amino Acids in Human Nutrition and Health* **2012**, 150-172.
56. Nowak, E. C.; de Vries, V. C.; Wasiuk, A.; Ahonen, C.; Bennett, K. A.; Le Mercier, I.; Ha, D.-G.; Noelle, R. J., Tryptophan hydroxylase-1 regulates immune tolerance and inflammation. *Journal of Experimental Medicine* **2012**, *209*, 2127-2135.
57. Joseph, P. G., Serotonergic and tryptaminergic overstimulation on refeeding implicated in "enlightenment" experiences. *Medical Hypotheses* **2012**, *79*, 598-601.
58. Richard, D. M.; Dawes, M. A.; Mathias, C. W.; Acheson, A.; Hill-Kapturczak, N.; Dougherty, D. M., L-tryptophan: basic metabolic functions, behavioral research and therapeutic Indications. *International Journal of Tryptophan Research* **2009**, *2*, 45-60.

59. Takada, M., Serotonin (5-HT). *Kekkan Rimoderingu to Shushoku Inshi* **1997**, 33-43.
60. Boadle-Biber, M. C., Biosynthesis of serotonin. *Biol. Serotonergic Transm.* **1982**, 63-94.
61. Torrente Mariana, P.; Gelenberg Alan, J.; Vrana Kent, E., Boosting serotonin in the brain: is it time to revamp the treatment of depression? *Journal of psychopharmacology (Oxford, England)* **2012**, 26, 629-35.
62. Donaldson, Z. R.; Nautiyal, K. M.; Ahmari, S. E.; Hen, R., Genetic approaches for understanding the role of serotonin receptors in mood and behavior. *Current Opinion in Neurobiology* **2013**, 23, 399-406.
63. Donaldson, Z. R.; Piel, D. A.; Santos, T. L.; Richardson-Jones, J.; Leonardo, E. D.; Beck, S. G.; Champagne, F. A.; Hen, R., Developmental Effects of Serotonin 1A Autoreceptors on Anxiety and Social Behavior. *Neuropsychopharmacology* **2014**, 39, 291-302.
64. Heinisch, S.; Kirby, L. G., Fractalkine/CX3CL1 enhances GABA synaptic activity at serotonin neurons in the rat dorsal raphe nucleus. *Neuroscience (Amsterdam, Netherlands)* **2009**, 164, 1210-1223.
65. Kilkens, T. O. C.; Honig, A.; van Nieuwenhoven, M. A.; Riedel, W. J.; Brummer, R. J. M., Acute tryptophan depletion affects brain-gut responses in irritable bowel syndrome patients and controls. *Gut* **2004**, 53, 1794-1800.
66. Newman, J. M. B.; Clark, M. G., Stimulation and inhibition of resting muscle thermogenesis by vasoconstrictors in perfused rat hind limb. *Canadian Journal of Physiology and Pharmacology* **1998**, 76, 867-872.

67. Amstein, R.; Fetkovska, N.; Luscher, T. F.; Kiowski, W.; Buhler, F. R., Age and the platelet serotonin vasoconstrictor axis in essential hypertension. *Journal of cardiovascular pharmacology* **1988**, *11 Suppl 1*, S35-40.
68. Pandi-Perumal, S. R.; Srinivasan, V.; Spence, D. W.; Cardinali, D. P., Role of the melatonin system in the control of sleep: therapeutic implications. *CNS Drugs* **2007**, *21*, 995-1018.
69. Bogan, J.; Rentoul, E.; Smith, H.; Weir, W. P., Homicidal poisoning by strychnine. *Journal of the Forensic Science Society* **1966**, *6*, 166-9.
70. Ekebergh, A.; Karlsson, I.; Mete, R.; Pan, Y.; Borje, A.; Maartensson, J., Oxidative Coupling as a Biomimetic Approach to the Synthesis of Scytonemin. *Organic Letters* **2011**, *13*, 4458-4461.
71. Brenowitz, S.; Castenholz, R. W., Long-term effects of UV and visible irradiance on natural populations of a scytonemin-containing cyanobacterium (*Calothrix* sp.). *FEMS Microbiology Ecology* **1997**, *24*, 343-352.
72. Balskus Emily, P.; Walsh Christopher, T., Investigating the initial steps in the biosynthesis of cyanobacterial sunscreen scytonemin. *J Am Chem Soc* **2008**, *130*, 15260-1.
73. Bultel-Ponce, V.; Felix-Theodose, F.; Sarthou, C.; Ponge, J. F.; Bodo, B., New pigments from the terrestrial cyanobacterium *Scytonema* sp. collected on the Mitaraka inselberg, French Guyana. *J Nat Prod* **2004**, *67*, 678-81.
74. Groniger, A.; Sinha, R. P.; Klisch, M.; Hader, D. P., Photoprotective compounds in cyanobacteria, phytoplankton and macroalgae - a

- database. *Journal of Photochemistry and Photobiology, B: Biology* **2000**, *58*, 115-122.
75. Shoguchi, E.; Tanaka, M.; Takeuchi, T.; Shinzato, C.; Satoh, N., Probing a coral genome for components of the photoprotective scytonemin biosynthetic pathway and the 2-aminoethylphosphonate pathway. *Marine Drugs* **2013**, *11*, 559-570.
76. Proteau, P. J.; Gerwick, W. H.; Garcia-Pichel, F.; Castenholz, R., The structure of scytonemin, an ultraviolet sunscreen pigment from the sheaths of cyanobacteria. *Experientia* **1993**, *49*, 825-9.
77. Singh, S. P.; Kumari, S.; Rastogi, R. P.; Singh, K. L.; Richa; Sinha, R. P., Photoprotective and biotechnological potentials of cyanobacterial sheath pigment, scytonemin. *African Journal of Biotechnology* **2010**, *9*, 580-588.
78. Balskus, E. P.; Walsh, C. T., An Enzymatic Cyclopentyl[b]indole Formation Involved in Scytonemin Biosynthesis. *Journal of the American Chemical Society* **2009**, *131*, 14648-14649.
79. Gao, Q.; Garcia-Pichel, F., Microbial ultraviolet sunscreens. *Nature Reviews Microbiology* **2011**, *9*, 791-802.
80. Varnali, T.; Edwards, H. G. M.; Hargreaves, M. D., Scytonemin: molecular structural studies of a key extremophilic biomarker for astrobiology. *International Journal of Astrobiology* **2009**, *8*, 133-140.
81. Biemann, K., Application of mass spectrometry to structure problems. IV. The carbon skeleton of sarpagine. *Journal of the American Chemical Society* **1961**, *83*, 4801-5.

82. Neukomm, G.; Hesse, M., Mass spectrometric studies. Part 30. The mass spectral retro-Diels-Alder reaction: 1,2,3,4-tetrahydrocarbazole. *Helvetica Chimica Acta* **1977**, *60*, 2431-5.
83. Gonzalo Rodriguez, J.; Urrutia, A.; Canoira, L., Electron impact mass spectrometry of indole derivatives. *International Journal of Mass Spectrometry and Ion Processes* **1996**, *152*, 97-110.
84. Ghahremanzadeh, R.; Ahadi, S.; Sayyafi, M.; Bazgir, A., Reaction of phthalhydrazide and acetylenedicarboxylates in the presence of N-heterocycles: an efficient synthesis of phthalazine derivatives. *Tetrahedron Letters* **2008**, *49*, 4479-4482.
85. Mogilaiah, K.; Chowdary, D. S.; Reddy, P. R.; Reddy, N. V., Mild and efficient synthesis of phthalazine-1,4-diones using PTSA in the solid state. *Synthetic Communications* **2003**, *33*, 127-131.
86. Joutsiniemi, K.; Leppila, P.; Vainiotalo, P., Extensive rearrangement reactions observed for differently N-substituted 2,5-dimethylpyrroles under electron ionization. *Rapid Communications in Mass Spectrometry* **1998**, *12*, 231-238.
87. Nyadong, L.; Quinn, J. P.; Hsu, C. S.; Hendrickson, C. L.; Rodgers, R. P.; Marshall, A. G., Atmospheric Pressure Laser-Induced Acoustic Desorption Chemical Ionization Mass Spectrometry for Analysis of Saturated Hydrocarbons. *Analytical Chemistry (Washington, DC, United States)* **2012**, *84*, 7131-7137.
88. McCarthy, E. D.; Han, J.; Calvin, M., Hydrogen atom transfer in mass spectrometric fragmentation patterns of saturated aliphatic hydrocarbons. *Analytical Chemistry* **1968**, *40*, 1475-80.

89. Williams, E. R., Supercharging, fast mixing, and charge detection in mass spectrometry. *Abstracts of Papers, 248th ACS National Meeting & Exposition, San Francisco, CA, United States, August 10-14, 2014* **2014**, ANYL-92.
90. Meng, Z.; Limbach, P. A., Mass spectrometry of nucleic acids. *Functional Genomics Series* **2002**, *1*, 197-233.
91. Havlicek, V.; Jegorov, A.; Sedmera, P., Mass spectrometry of cyclosporins. *New Advances in Analytical Chemistry* **2000**, P2/339-P2/368.
92. Stobiecki, M., Application of mass spectrometry for identification and structural studies of flavonoid glycosides. *Phytochemistry* **2000**, *54*, 237-256.
93. Richardin, P., Contribution of mass spectrometry to the study of our cultural heritage. *Spectra Analyse* **1996**, *25*, 27-33.
94. Horn, A. B., Infrared molecular vibrational spectroscopy. *Encyclopedia of Applied Spectroscopy* **2009**, 887-932.
95. Reich, G., Near-infrared spectroscopy and imaging: Basic principles and pharmaceutical applications. *Advanced Drug Delivery Reviews* **2005**, *57*, 1109-1143.
96. Lozada-Garcia, R. R.; Ceponkus, J.; Chin, W.; Chevalier, M.; Crepin, C., Acetylacetone in hydrogen solids: IR signatures of the enol and keto tautomers and UV induced tautomerization. *Chemical Physics Letters* **2011**, *504*, 142-147.
97. Turrell, G., The Raman effect. *Raman Microscopy* **1996**, 9-25.

98. Long, D. A., Introduction to Raman spectroscopy. *RSC Analytical Spectroscopy Monographs* **2005**, 9, 17-40.
99. Venkatarayudu, T., The rule of mutual exclusion. *Journal of Chemical Physics* **1954**, 22, 1269.
100. Lupoi Jason, S.; Gjersing, E.; Davis Mark, F., Evaluating lignocellulosic biomass, its derivatives, and downstream products with Raman spectroscopy. *Frontiers in bioengineering and biotechnology* **2015**, 3, 50.
101. Kendall, C.; Hutchings, J.; Barr, H.; Shepherd, N.; Stone, N., Exploiting the diagnostic potential of biomolecular fingerprinting with vibrational spectroscopy. *Faraday Discussions* **2011**, 149, 279-290.
102. Clemo, G. R.; Felton, D. G. I., Chemistry of carbazoles. 1,2,3,4-Tetrahydro-4-ketocarbazole. *Journal of the Chemical Society* **1951**, 700-3.
103. Allen, F. H., The Cambridge Structural Database: a quarter of a million crystal structures and rising. *Acta Crystallographica, Section B: Structural Science* **2002**, B58, 380-388.
104. Rodriguez, J. G.; Temprano, F.; Esteban-Calderon, C.; Martinez-Ripoll, M., Synthesis of 4-(N,N-dimethylaminoethyl)-1,2,3,4-tetrahydrocarbazole: molecular structure and reactivity of the 1,2-dihydrocarbazol-4(3H)-one and derivatives. *Journal of the Chemical Society, Perkin Transactions 1: Organic and Bio-Organic Chemistry (1972-1999)* **1989**, 2117-22.
105. Inman, M.; Moody, C. J., Indole synthesis - something old, something new. *Chemical Science* **2013**, 4, 29-41.

106. Barluenga, J.; Valdes, C., Five-membered heterocycles: indole and related systems. *Modern Heterocyclic Chemistry* **2011**, *1*, 377-531.
107. Song Jinhua, J.; Reeves Jonathan, T.; Gallou, F.; Tan, Z.; Yee Nathan, K.; Senanayake Chris, H., Organometallic methods for the synthesis and functionalization of azaindoles. *Chem Soc Rev* **2007**, *36*, 1120-32.
108. Bi, W. J.; Li, X. J.; Zhang, G.-l.; Zhang, F.-b., Progress in synthesis and functionalization of 7-substituted indole catalyzed by palladium. *Huaxue Gongye Yu Gongcheng (Tianjin, China)* **2007**, *24*, 446-452.
109. Dobbs, A., Total Synthesis of Indoles from Tricholoma Species via Bartoli/Heteroaryl Radical Methodologies. *Journal of Organic Chemistry* **2001**, *66*, 638-641.
110. Shorygin, P. P.; Polyakova, K. S., Production of indole. *Sintezy Dushistykh Veshchestv, Sbornik Statei* **1939**, 130-6.
111. Li, J.; Cook, J. M., Reissert indole synthesis. *Name Reactions in Heterocyclic Chemistry* **2005**, 154-158.
112. Dobson, D. R.; Gilmore, J.; Long, D. A., Synthesis of 7-formylindole using the Bartoli indole methodology. *Synlett* **1992**, 79-80.
113. Li, J.; Cook, J. M., Gassman indole synthesis. *Name Reactions in Heterocyclic Chemistry* **2005**, 128-131.
114. Han, Y., Mori-Ban indole synthesis. *Name Reactions in Heterocyclic Chemistry II* **2011**, 175-186.
115. Wang, C.; Sperry, J., Schischkiniin support studies: synthetic access to 1,1'-bisindoles. *Chemical Communications (Cambridge, United Kingdom)* **2013**, *49*, 4349-4351.

116. Zhu, G. H.; Yu, L. M.; Zhang, Q.; Zhang, Z. J.; Li, X., Mechanism of Fischer indole synthesis and its applications. *Guangzhou Huagong* **2012**, *40*, 6-8.
117. Alford, P. E.; Fu, L.; Kubert, J. K.; Wang, L.; Gribble, G. W., A convenient Fischer indole synthesis of 2,3'-biindoles. *Tetrahedron Letters* **2011**, *52*, 2642-2644.
118. Larock, R. C.; Yum, E. K.; Refvik, M. D., Synthesis of 2,3-Disubstituted Indoles via Palladium-Catalyzed Annulation of Internal Alkynes. *Journal of Organic Chemistry* **1998**, *63*, 7652-7662.
119. Rosas-Garcia, V. M.; Quintanilla-Licea, R.; Longoria R, F. E., The Fischer indole synthesis: a semiempirical study. *ECHET98: Electronic Conference on Heterocyclic Chemistry, June 29-July 24, 1998* **1998**, 237-243.
120. Robinson, G. M.; Robinson, R., New synthesis of tetraphenylpyrrole. *Journal of the Chemical Society, Transactions* **1918**, *113*, 639-45.
121. Bajwa, G. S.; Brown, R. K., The dienone-imine intermediate in the Fischer indole synthesis. *Canadian Journal of Chemistry* **1968**, *46*, 3105-9.
122. Clusius, K.; Weisser, H. R., Reactions with nitrogen¹⁵. III. Mechanism of the Fischer indole synthesis. *Helvetica Chimica Acta* **1952**, *35*, 400-6.
123. Allen, C. F. H.; Wilson, C. V., Use of N¹⁵ as a tracer element in chemical reactions. The mechanism of the Fischer indole synthesis. *Journal of the American Chemical Society* **1943**, *65*, 611-12.

124. Wagaw, S.; Yang, B. H.; Buchwald, S. L., A palladium-catalyzed method for the preparation of indoles via the Fischer indole synthesis. *Journal of the American Chemical Society* **1999**, *121*, 10251-10263.
125. Mills, K.; Al Khawaja, I. K.; Al-Saleh, F. S.; Joule, J. A., Fischer indole synthesis of 3-acyl- and 3-alkoxycarbonylindoles. *Journal of the Chemical Society, Perkin Transactions 1: Organic and Bio-Organic Chemistry (1972-1999)* **1981**, 636-41.
126. Pausacker, K. H., Fischer indole synthesis. III. Cyclization of the phenylhydrazones of some 2-substituted cyclohexanones. *Journal of the Chemical Society* **1950**, 621-4.
127. Stoermer, D.; Heathcock, C. H., Total synthesis of (-)-alloaristoteline, (-)-serratoline, and (+)-aristotelone. *Journal of Organic Chemistry* **1993**, *58*, 564-8.
128. Kelly, A. H.; McLeod, D. H.; Parrick, J., Thermal indolization of arylhydrazones. *Canadian Journal of Chemistry* **1965**, *43*, 296-301.
129. Rogers, C. U.; Corson, B. B., 1,2,3,4-Tetrahydrocarbazole. *Organic Syntheses* **1950**, *30*, 90-2.
130. Coffey, S., Some derivatives of 1,2-cyclohexanedione. *Recueil des Travaux Chimiques des Pays-Bas et de la Belgique* **1923**, *42*, 528-32.
131. Vankar, Y. D.; Chaudhuri, N. C.; Rao, C. T., Regioselective reductions of 2,3-epoxy acetals with zinc-chlorotrimethylsilane and lithium aluminum hydride: convenient synthesis of 1,2- and 1,3-diones. *Tetrahedron Letters* **1987**, *28*, 551-4.
132. Vankar, Y. D.; Reddy, M. V.; Chaudhuri, N. C., Studies in asymmetric synthesis. 2. Chiral acetals in organic synthesis: regioselective

- synthesis of 2- and 3-hydroxy acetals from 2,3-olefinic acetals. Reinvestigation and further applications. *Tetrahedron* **1994**, *50*, 11057-78.
133. Oikawa, Y.; Yonemitsu, O., Selective oxidation of the side chain at C-3 of indoles. *Journal of Organic Chemistry* **1977**, *42*, 1213-16.
134. Li, X.; Vince, R., Conformationally restrained carbazolone-containing α,γ -diketo acids as inhibitors of HIV integrase. *Bioorganic & Medicinal Chemistry* **2006**, *14*, 2942-2955.
135. Carr, G.; Whittaker, D., Lactone formation in superacidic media. *Journal of the Chemical Society, Perkin Transactions 2: Physical Organic Chemistry (1972-1999)* **1987**, 1877-80.
136. Aubagnac, J. L.; Campion, P.; Guenot, P., Mass spectrometry of nitrogen heterocycles. VII. 1-Phenyl-1,2,3-triazole. *Organic Mass Spectrometry* **1978**, *13*, 571-4.
137. Aubagnac, J. L.; Campion, P., Mass spectrometry of nitrogen heterocycles. X. Contribution to the behavior of the aniline ion and aminopyridine ions prior to fragmentation by loss of hydrogen cyanide. *Organic Mass Spectrometry* **1979**, *14*, 425-9.
138. Sridevi, C.; Velraj, G., Structural, vibrational, electronic, NMR, NLO and reactivity analyses of (3Z)-3-(2-oxo-2-phenylethylidene)-1,3-dihydro-2H-indol-2-one (OPEDI) by ab initio HF and DFT calculations. *Spectrochimica Acta, Part A: Molecular and Biomolecular Spectroscopy* **2013**, *107*, 334-346.

139. Gunasekaran, S.; Sailatha, E.; Seshadri, S.; Kumaresan, S., FTIR, FT Raman spectra and molecular structural confirmation of isoniazid. *Indian Journal of Pure and Applied Physics* **2009**, *47*, 12-18.
140. Saleem, H.; Subashchandrabose, S.; Erdogdu, Y.; Thanikachalam, V.; Jayabharathi, J., FT-IR, FT-Raman spectral and conformational studies on (E)-2-(2-hydroxybenzylidenamino)-3-(1H-indol-3yl) propionic acid. *Spectrochimica Acta, Part A: Molecular and Biomolecular Spectroscopy* **2013**, *101*, 91-99.
141. Cinar, M.; Karabacak, M., Determination of conformational and spectroscopic features of ethyl trans-alfa-cyano-3-indole-acrylate compound: An experimental and quantum chemical study. *Spectrochimica Acta, Part A: Molecular and Biomolecular Spectroscopy* **2013**, *104*, 428-436.
142. Arjunan, V.; Puviarasan, N.; Mohan, S., Fourier transform infrared and Raman spectral investigations of 5-aminoindole. *Spectrochimica Acta, Part A: Molecular and Biomolecular Spectroscopy* **2006**, *64A*, 233-239.
143. Puviarasan, N.; Arjunan, V.; Mohan, S., FT-IR and FT-Raman studies on 3-aminophthalhydrazide and N-aminophthalimide. *Turkish Journal of Chemistry* **2002**, *26*, 323-333.
144. Tanner, E. M., The infrared absorption spectra of some indole-3-ketones. *Spectrochimica Acta* **1957**, *9*, 282-6.
145. Gilchrist, T. L., *Heterocyclic Chemistry, 2nd Edition*. 1992; p 396 .

146. Elguero, J.; Marzin, C.; Katritzky, A. R.; Linda, P., *Advances in Heterocyclic Chemistry, Supplement 1: The Tautomerism of Heterocycles*. 1976; p 656 .
147. Sundaraganesan, N.; Umamaheswari, H.; Joshua, B. D.; Meganathan, C.; Ramalingam, M., Molecular structure and vibrational spectra of indole and 5-aminoindole by density functional theory and ab initio Hartree-Fock calculations. *Journal of Molecular Structure: THEOCHEM* **2008**, *850*, 84-93.
148. Li, X.; Li, J.; Li, W.; Zhou, X.; Li, Q.; Li, Z.; Qin, J.; Hu, J., Spectroscopic and quantum mechanical study of three novel azo-materials containing indole and sulfonyl based chromophores. *Spectrochimica Acta, Part A: Molecular and Biomolecular Spectroscopy* **2013**, *105*, 593-599.
149. Mann, F. G.; Willcox, T. J., Synthesis of indolo[2',3',1,2]- and indolo[3',2',1,2]carbazole. *Journal of the Chemical Society* **1958**, 1525-9.
150. Lambert, J. B.; Shurvell, H. F.; Lightner, D. A.; Cooks, R. G., *Organic Structural Spectroscopy*. 1998; p 568.
151. Dole, M.; Mack, L. L.; Hines, R. L.; Mobley, R. C.; Ferguson, L. D.; Alice, M. B., Molecular beams of macroions. *Journal of Chemical Physics* **1968**, *49*, 2240-9.
152. Yamashita, M.; Fenn, J. B., Electrospray ion source. Another variation on the free-jet theme. *Journal of Physical Chemistry* **1984**, *88*, 4451-9.
153. Light-Wahl, K. J.; Springer, D. L.; Winger, B. E.; Edmonds, C. G.; Camp, D. G., II; Thrall, B. D.; Smith, R. D., Observation of a small

- oligonucleotide duplex by electrospray ionization mass spectrometry. *J. Am. Chem. Soc.* **1993**, *115*, 803-4.
154. Huang, E. C.; Pramanik, B. N.; Tsarbopoulos, A.; Reichert, P.; Ganguly, A. K.; Trotta, P. P.; Nagabhushan, T. L.; Covey, T. R., Application of electrospray mass spectrometry in probing protein-protein and protein-ligand noncovalent interactions. *J. Am. Soc. Mass Spectrom.* **1993**, *4*, 624-30.
155. Ganem, B.; Li, Y. T.; Henion, J. D., Observation of noncovalent enzyme-substrate and enzyme-product complexes by ion-spray mass spectrometry. *J. Am. Chem. Soc.* **1991**, *113*, 7818-19.
156. Pan, H., A non-covalent dimer formed in electrospray ionisation mass spectrometry behaving as a precursor for fragmentations. *Rapid Commun Mass Spectrom* **2008**, *22*, 3555-60.
157. Ding, J.; Anderegg, R. J., Specific and nonspecific dimer formation in the electrospray ionization mass spectrometry of oligonucleotides. *J. Am. Soc. Mass Spectrom.* **1995**, *6*, 159-64.
158. Ganem, B.; Li, Y. T.; Henion, J. D., Detection of noncovalent receptor-ligand complexes by mass spectrometry. *J. Am. Chem. Soc.* **1991**, *113*, 6294-6.
159. Mautjana, N. A.; Estes, J.; Eyler, J. R.; Brajter-Toth, A., Antioxidant pathways and one-electron oxidation of dopamine and cysteine in electrospray and on-line electrochemistry electrospray ionization mass spectrometry. *Electroanalysis* **2008**, *20*, 1959-1967.
160. Jiang, H.; Somogyi, A.; Timmermann, B. N.; Gang, D. R., Instrument dependence of electrospray ionization and tandem mass

- spectrometric fragmentation of the gingerols. *Rapid Communications in Mass Spectrometry* **2006**, *20*, 3089-3100.
161. Yamdagni, R.; Kebarle, P., Gas-phase basicities of amines. Hydrogen bonding in proton-bound amine dimers and proton-induced cyclization of α, ω -diamines. *J. Am. Chem. Soc.* **1973**, *95*, 3504-10.
 162. McLuckey, S. A.; Cameron, D.; Cooks, R. G., Proton affinities from dissociations of proton-bound dimers. *J. Am. Chem. Soc.* **1981**, *103*, 1313-17.
 163. Larson, J. W.; McMahon, T. B., Formation, thermochemistry, and relative stabilities of proton-bound dimers of oxygen n-donor bases from ion cyclotron resonance solvent-exchange equilibrium measurements. *J. Am. Chem. Soc.* **1982**, *104*, 6255-61.
 164. Cheng, X.; Wu, Z.; Fenselau, C., Collision energy dependence of proton-bound dimer dissociation: entropy effects, proton affinities, and intramolecular hydrogen-bonding in protonated peptides. *J. Am. Chem. Soc.* **1993**, *115*, 4844-8.
 165. Morton, T. H., Gas phase analogs of solvolysis reactions. *Tetrahedron* **1982**, *38*, 3195-243.
 166. McAdoo, D. J., Ion-neutral complexes in unimolecular decompositions. *Mass Spectrom. Rev.* **1988**, *7*, 363-93.
 167. Bowen, R. D., Ion-neutral complexes. *Acc. Chem. Res.* **1991**, *24*, 364-71.
 168. Longevialle, P., Ion-neutral complexes in the unimolecular reactivity of organic cations in the gas phase. *Mass Spectrom. Rev.* **1992**, *11*, 157-92.

169. Jennings, K. R., The changing impact of the collision-induced decomposition of ions on mass spectrometry. *Int. J. Mass Spectrom.* **2000**, *200*, 479-493.
170. Mueller, T.; Badu-Tawiah, A.; Cooks, R. G., Accelerated Carbon-Carbon Bond-Forming Reactions in Preparative Electrospray. *Angewandte Chemie, International Edition* **2012**, *51*, 11832-11835.
171. Smith, G. F.; Walters, A. E., Indoles. V. 3-Alkylindole dimers. *J. Chem. Soc.* **1961**, 940-3.
172. McComas, C. C.; Gilbert, E. J.; Van Vranken, D. L., Stereochemistry of 3-Alkylindole Dimerization: Acyclic 1,1'-Tryptophan Dimers. *J. Org. Chem.* **1997**, *62*, 8600-8603.
173. Ishikawa, H.; Takayama, H.; Aimi, N., Dimerization of indole derivatives with hypervalent iodines(III): a new entry for the concise total synthesis of rac- and meso-chimonanthines. *Tetrahedron Lett.* **2002**, *43*, 5637-5639.
174. Bao, B.; Sun, Q.; Yao, X.; Hong, J.; Lee, C.-O.; Cho, H. Y.; Jung, J. H., Bisindole Alkaloids of the Topsentin and Hamacanthin Classes from a Marine Sponge *Spongisorites* sp. *J. Nat. Prod.* **2007**, *70*, 2-8.
175. Casapullo, A.; Bifulco, G.; Bruno, I.; Riccio, R., New bisindole alkaloids of the topsentin and hamacanthin classes from the Mediterranean marine sponge *Rhaphisia lacazei*. *J. Nat. Prod.* **2000**, *63*, 447-51.
176. Miyake, F. Y.; Yakushijin, K.; Horne, D. A., A Concise Synthesis of Topsentin A and Nortopsentins B and D. *Org Lett* **2000**, *2*, 2121-2123.

177. Burres, N. S.; Barber, D. A.; Gunasekera, S. P.; Shen, L. L.; Clement, J. J., Antitumor activity and biochemical effects of topsentin. *Biochem Pharmacol* **1991**, *42*, 745-51.
178. STRYCHNINE AS AN ANTIDOTE TO SNAKE POISON. *The Lancet* **1891**, *138*, 959-960.
179. Bao, B.; Sun, Q.; Yao, X.; Hong, J.; Lee Chong, O.; Sim Chung, J.; Im Kwang, S.; Jung Jee, H., Cytotoxic bisindole alkaloids from a marine sponge *Spongisorites* sp. *J. Nat. Prod.* **2005**, *68*, 711-5.
180. Shoeb, M.; Celik, S.; Jaspars, M.; Kumarasamy, Y.; MacManus, S. M.; Nahar, L.; Thoo-Lin, P. K.; Sarker, S. D., Isolation, structure elucidation and bioactivity of schischkiniin, a unique indole alkaloid from the seeds of *Centaurea schischkini*. *Tetrahedron* **2005**, *61*, 9001-9006.
181. Kaswasaki, I.; Yamashita, m.; Ohta, S., Successive diarylation at the carbon positions (2/4 and 2/5) of 1H-imidazole and its application to the total synthesis of nortopsentin D. *Journal of the Chemical Society, Chemical Communications* **1994**, 2085-6.
182. Achab, S., A three-component coupling approach to the marine bisindole alkaloids: topsentin, deoxytopsentin and bromotopsentin. *Tetrahedron Letters* **1996**, *37*, 5503-5506.
183. Braekman, J. C.; Daloze, D.; Stoller, C., Synthesis of topsentin-A, a bisindole alkaloid of the marine sponge *Topsentia genitrix*. *Bulletin des Societes Chimiques Belges* **1987**, *96*, 809-12.

184. Braekman, J. C.; Daloze, D.; Moussiaux, B.; Stoller, C.; Deneubourg, F., Sponge secondary metabolites: new results. *Pure and Applied Chemistry* **1989**, *61*, 509-12.
185. Wang, C.; Sperry, J., Schischkiniin support studies: synthetic access to 1,1'-bisindoles. *Chem. Commun. (Cambridge, U. K.)* **49**, 4349-4351.
186. Yang, H.; Sun, P.; Zhu, Y.; Yan, H.; Lu, L.; Liu, D.; Rong, G.; Mao, J., Palladium-catalyzed synthesis of indoles via intramolecular Heck reaction. *Catalysis Communications* **2013**, *38*, 21-25.
187. Willis, M. C.; Taylor, D.; Gillmore, A. T., Palladium-catalyzed intramolecular O-arylation of enolates: Application to benzo[b]furan synthesis. *Organic Letters* **2004**, *6*, 4755-4757.
188. Willis, M. C.; Taylor, D.; Gillmore, A. T., Palladium-catalyzed intramolecular enolate O-arylation and thio-enolate S-arylation: synthesis of benzo[b]furans and benzo[b]thiophenes. *Tetrahedron* **2006**, *62*, 11513-11520.
189. Melkonyan, F. S.; Kuznetsov, D. E.; Yurovskaya, M. A.; Karchava, A. V., One-pot synthesis of substituted indoles via titanium(iv) alkoxide mediated imine formation copper-catalyzed N-arylation. *RSC Advances* **2013**, *3*, 8388-8397.
190. Melkonyan, F. S.; Karchava, A. V.; Yurovskaya, M. A., Synthesis of N-Substituted Indole-3-carboxylic Acid Derivatives via Cu(I)-Catalyzed Intramolecular Amination of Aryl Bromides. *Journal of Organic Chemistry* **2008**, *73*, 4275-4278.
191. Ruiz, M.; Sanchez, J. D.; Lopez-Alvarado, P.; Menendez, J. C., A systematic study of two complementary protocols allowing the general,

- mild and efficient deprotection of N-pivaloylindoles. *Tetrahedron* **2012**, *68*, 705-710.
192. Liu, Q.; Zhao, Q. Y.; Liu, J.; Wu, P.; Yi, H.; Lei, A., A trans diacyloxylation of indoles. *Chemical Communications (Cambridge, UK)* **2012**, *48*, 3239-3241.
193. Macleod, C.; McKiernan, G. J.; Guthrie, E. J.; Farrugia, L. J.; Hamprecht, D. W.; Macritchie, J.; Hartley, R. C., Synthesis of 2-Substituted Benzofurans and Indoles Using Functionalized Titanium Benzylidene Reagents on Solid Phase. *Journal of Organic Chemistry* **2003**, *68*, 387-401.
194. Mendiola, J.; Baeza, A.; Alvarez-Builla, J.; Vaquero, J. J., Reaction of Bromomethylazoles and Tosylmethyl Isocyanide. A Novel Heterocyclization Method for the Synthesis of the Core of Marine Alkaloids Variolins and Related Azolopyrimidines. *Journal of Organic Chemistry* **2004**, *69*, 4974-4983.
195. Young, I. S.; Baran, P. S., Protecting-group-free synthesis as an opportunity for invention. *Nature Chemistry* **2009**, *1*, 193-205.
196. Lin, X.; Dorr, H.; Nuss, J. M., Utilization of Fukuyama's sulfonamide protecting group for the synthesis of N-substituted α -amino acids and derivatives. *Tetrahedron Letters* **2000**, *41*, 3309-3313.
197. Naito, H.; Hata, T.; Urabe, H., Selective Deprotection of Methanesulfonamides to Amines. *Organic Letters* **2010**, *12*, 1228-1230.
198. Ragnarsson, U.; Grehn, L., Dual protection of amino functions involving Boc. *RSC Advances* **2013**, *3*, 18691-18697.

199. Patel, D. R.; Patel, K. C., Synthesis and characterization of reactive dyes based on 2-phenyl-3-[4'-(4''-aminophenylsulphonamido)]phenyl-4(3H)-quinazolinone-6-sulphonic acid. *Arabian Journal of Chemistry* **2010**, *4*, 279-285.
200. Wang, F.; Wang, L.; Cai, X.; Sun, Y.; Su, L.; Zhang, L.; Han, Z.; Zhang, G.; Wang, G., Synthesis of branched azo dyes based on benzene sulfonamide intermediates and their spectral properties. *Coloration Technology* **2012**, *128*, 425-433.
201. Abd-Alredha, L.; Al-Rubaie, R.; Jameel Mhessn, R., Synthesis and characterization of azo dye para red and new derivatives. *Journal of Chemistry* **2012**, *9*, 465-470.
202. Schmidt, B.; Wolf, F.; Brunner, H., Styrylsulfonates and -Sulfonamides through Pd-Catalysed Matsuda-Heck Reactions of Vinylsulfonic Acid Derivatives and Arenediazonium Salts. *European Journal of Organic Chemistry* **2016**, Ahead of Print.
203. DeBergh, J. R.; Niljianskul, N.; Buchwald, S. L., Synthesis of Aryl Sulfonamides via Palladium-Catalyzed Chlorosulfonylation of Arylboronic Acids. *Journal of the American Chemical Society* **2013**, *135*, 10638-10641.
204. Wales, J. K.; Krees, S. V.; Grant, A. M.; Viktora, J. K.; Wolff, F. W., Structure-activity relations of benzothiadiazine compounds as hyperglycemic agents. *Journal of Pharmacology and Experimental Therapeutics* **1968**, *164*, 421-31.
205. Cherney, R. J.; Mo, R.; Meyer, D. T.; Hardman, K. D.; Liu, R.-Q.; Covington, M. B.; Qian, M.; Wasserman, Z. R.; Christ, D. D.; Trzaskos,

- J. M.; Newton, R. C.; Decicco, C. P., Sultam Hydroxamates as Novel Matrix Metalloproteinase Inhibitors. *Journal of Medicinal Chemistry* **2004**, *47*, 2981-2983.
206. Wells, G. J.; Tao, M.; Josef, K. A.; Bihovsky, R., 1,2-Benzothiazine 1,1-Dioxide P2-P3 Peptide Mimetic Aldehyde Calpain I Inhibitors. *Journal of Medicinal Chemistry* **2001**, *44*, 3488-3503.
207. Misu, Y.; Togo, H., Novel preparation of 2,1-benzothiazine derivatives from sulfonamides with [hydroxy(tosyloxy)iodo]arenes. *Organic & Biomolecular Chemistry* **2003**, *1*, 1342-1346.
208. Toure, B. B.; Miller-Moslin, K.; Yusuff, N.; Perez, L.; Dore, M.; Joud, C.; Michael, W.; DiPietro, L.; van der Plas, S.; McEwan, M.; Lenoir, F.; Hoe, M.; Karki, R.; Springer, C.; Sullivan, J.; Levine, K.; Fiorilla, C.; Xie, X.; Kulathila, R.; Herlihy, K.; Porter, D.; Visser, M., The Role of the Acidity of N-Heteroaryl Sulfonamides as Inhibitors of Bcl-2 Family Protein-Protein Interactions. *ACS Medicinal Chemistry Letters* **2013**, *4*, 186-190.
209. Seydel, J. K., Mode of action and quantitative structure-activity relationship of sulfonamides in biological systems of different complexity (enzymes, bacteria, rat, and human). *International Journal of Quantum Chemistry* **1981**, *20*, 131-50.
210. Guianvarc'h, D.; Duca, M.; Boukarim, C.; Kraus-Berthier, L.; Leonce, S.; Pierre, A.; Pfeiffer, B.; Renard, P.; Arimondo, P. B.; Monneret, C.; Dauzonne, D., Synthesis and Biological Activity of Sulfonamide Derivatives of Epipodophyllotoxin. *Journal of Medicinal Chemistry* **2004**, *47*, 2365-2374.

211. Saeedi, M.; Goli, F.; Mahdavi, M.; Dehghan, G.; Faramarzi, M. A.; Foroumadi, A.; Shafiee, A., Synthesis and biological investigation of some novel sulfonamide and amide derivatives containing coumarin moieties. *Iranian Journal of Pharmaceutical Research* **2014**, *13*, 881-892.
212. Woods, D. D., The biochemical mode of action of the sulfonamide drugs. *Journal of General Microbiology* **1962**, *29*, 687-702.
213. Mathew, N. T.; Asgharnejad, M.; Peykamian, M.; Laurenza, A., Naratriptan is effective and well tolerated in the acute treatment of migraine. Results of a double-blind, placebo-controlled, crossover study. *Neurology* **1997**, *49*, 1485-1490.
214. Rapoport, A. M.; Ramadan, N. M.; Adelman, J. U.; Mathew, N. T.; Elkind, A. H.; Kudrow, D. B.; Earl, N. L., Optimizing the dose of zolmitriptan (Zomig, 311C90) for the acute treatment of migraine. A multicenter, double-blind, placebo-controlled, dose range-finding study. *Neurology* **1997**, *49*, 1210-1218.
215. Klassen, A.; Elkind, A.; Asgharnejad, M.; Webster, C.; Laurenza, A., Naratriptan is effective and well tolerated in the acute treatment of migraine. Results of a double-blind, placebo-controlled, parallel-group study. Naratriptan S2WA3001 Study Group. *Headache* **1997**, *37*, 640-5.
216. Hoffmann, S., Silver sulfadiazine: an antibacterial agent for topical use in burns. A review of the literature. *Scandinavian journal of plastic and reconstructive surgery* **1984**, *18*, 119-26.

217. Carr, H. S.; Wlodkowski, T. J.; Rosenkranz, H. S., Silver sulfadiazine. In vitro antibacterial activity. *Antimicrobial Agents and Chemotherapy* **1973**, *4*, 585-7.
218. Zelder, F.; Sonnay, M.; Prieto, L., Antivitamins for Medicinal Applications. *ChemBioChem* **2015**, *16*, 1264-1278.
219. Wainwright, M.; Kristiansen, J. E., On the 75th anniversary of Prontosil. *Dyes and Pigments* **2010**, *88*, 231-234.
220. Alfare, K.; Lee, D.; Scharrer, E.; Van Arman, S. A., Preparation of azo dyes from sulfanilamide. *Chemical Educator* **2004**, *9*, 89-90.
221. Macarovici, C. G. H., Reaction of prontosil album. *Buletinul Societatii de Stiinte din Cluj* **1940**, *9*, 426-31.
222. Supuran, C. T.; Casini, A.; Scozzafava, A., Protease inhibitors of the sulfonamide type: anticancer, antiinflammatory, and antiviral agents. *Medicinal Research Reviews* **2003**, *23*, 535-558.
223. Spielmeyer, A.; Heer, M.; Mohring, S. A. I.; Hausmann, H.; Stahl, J.; Kietzmann, M.; Dold, S.; Spengler, B.; Hamscher, G., UV-Irradiation of the Antibiotic Sulfathiazole Surprisingly Leads to Former Antituberculous Promizole. *Clean: Soil, Air, Water* **2015**, *43*, 490-495.
224. Surekha, V.; Peter, J. V.; Jeyaseelan, L.; Cherian, A. M., Drug interaction: rifampicin and glibenclamide. *The National medical journal of India* **1997**, *10*, 11-2.
225. Lyden, P.; Pereira, B.; Chen, B.; Zhao, L.; Lamb, J.; Lei, I. f.; Rajput, P., Direct Thrombin Inhibitor Argatroban Reduces Stroke Damage in 2 Different Models. *Stroke* **2014**, *45*, 896-899.

226. Wood, W. B., Jr.; Irons, E. N., Mechanism of recovery in pneumococcal pneumonia. II. Effect of sulfonamide therapy on the pulmonary lesion of experimental pneumonia. *Journal of Experimental Medicine* **1946**, *84*, 365-76.
227. Levitt, A.; Schweitzer, H. T.; Goldstein, K., Sodium sulfapyridine monohydrate intravenously in the treatment of lobar pneumonia. *Journal of Laboratory and Clinical Medicine* **1942**, *27*, 443-7.
228. Lee, S. D.; Chan, T. H.; Kwon, K. S., Rearrangement of α -(acyloxy)acetates into 2-hydroxy-3-keto esters. *Tetrahedron Letters* **1984**, *25*, 3399-402.
229. Fuji, K.; Kawabata, T., Memory of chirality - a new principle in enolate chemistry. *Chemistry - A European Journal* **1998**, *4*, 373-376.
230. Wipf, P.; Methot, J.-L., Synthetic Studies toward Diazonamide A. A Novel Approach for Polyoxazole Synthesis. *Organic Letters* **2001**, *3*, 1261-1264.
231. Wender, P. A.; Marquess, D. G.; McGrane, L. P.; Taylor, R. E., First total synthesis of taxol. 1. Functionalization of the B ring and first total synthesis of taxol. 2. Completion of the C and D rings. Total synthesis of taxol. *Chemtracts: Organic Chemistry* **1994**, *7*, 160-71.
232. Giji, S.; Abirami, P.; Arumugam, M.; Balasubramaniam, T., HPTLC screening of amino acids from alcoholic extracts of four molluscan species along the South East Coast of India. *Journal of Chemical and Pharmaceutical Research* **2011**, *3*, 93-100.

233. Akram, M.; Asif, H. M.; Uzair, M.; Akhtar, N.; Madni, A.; Shah, S. M. A.; Zahoor ul, H.; Ullah, A., Amino acids: a review article. *Journal of Medicinal Plants Research* **2011**, *5*, 3997-4000.
234. Chiu, K.-H.; Wang, S. J., Arsenic toxicity and environmental problems. *Abstracts of Papers, 231st ACS National Meeting, Atlanta, GA, United States, March 26-30, 2006* **2006**, ENVR-013.
235. Dunlap, K. A.; Brown, J. D.; Keith, A. B.; Satterfield, M. C., Factors controlling nutrient availability to the developing fetus in ruminants. *Journal of Animal Science and Biotechnology* **2015**, *6*, 1-24.
236. Rudnick, G.; Kramer, R.; Blakely, R. D.; Murphy, D. L.; Verrey, F., The SLC6 transporters: perspectives on structure, functions, regulation, and models for transporter dysfunction. *Pfluegers Archiv* **2014**, *466*, 25-42.
237. Park, J. C.; Kim, Y. B.; Yoon, J. H.; Kim, H. J.; Kim, S. M.; Kanai, Y.; Endou, H.; Kim, D. K., Preferential expression of L-type amino acid transporter 1 in ameloblasts during rat tooth development. *Anatomia, histologia, embryologia* **2004**, *33*, 119-24.
238. Shaffer Paul, L.; Goehring, A.; Shankaranarayanan, A.; Gouaux, E., Structure and mechanism of a Na⁺-independent amino acid transporter. *Science (New York, N.Y.)* **2009**, *325*, 1010-4.
239. Kawabata, T.; Wirth, T.; Yahiro, K.; Suzuki, H.; Fujii, K., Direct Asymmetric α -Alkylation of Phenylalanine Derivatives Using No External Chiral Sources. *Journal of the American Chemical Society* **1994**, *116*, 10809-10.

240. Kawabata, T.; Yahiro, K.; Fuji, K., Memory of chirality: enantioselective alkylation reactions at an asymmetric carbon adjacent to a carbonyl group. *Journal of the American Chemical Society* **1991**, *113*, 9694-6.
241. Kawabata, T.; Fuji, K., Memory of chirality: asymmetric induction based on the dynamic chirality of enolates. *Topics in Stereochemistry* **2003**, *23*, 175-205.
242. Carlier, P. R., Memory of chirality for the asymmetric synthesis of quaternary benzodiazepines. *Abstracts, 58th Southeast Regional Meeting of the American Chemical Society, Augusta, GA, United States, November 1-4* **2006**, SRM06-006.
243. Wanyoike, G. N. a. a.; Onomura, O.; Maki, T.; Matsumura, Y., Highly Enhanced Enantioselectivity in the Memory of Chirality via Acyliminium Ions. *Organic Letters* **2002**, *4*, 1875-1877.
244. Kawabata, T.; Fuji, K., Memory of chirality: Alkylation of α -amino acid derivatives. *Yuki Gosei Kagaku Kyokaishi* **2000**, *58*, 1095-1099.
245. Seebach, D.; Wasmuth, D., Alkylation of amino acids without loss of optical activity: α - and β -alkylation of an aspartic acid derivative. *Angewandte Chemie* **1981**, *93*, 1007-8.
246. Zhao, H.; Hsu, D. C.; Carlier, P. R., Memory of chirality. An emerging strategy for asymmetric synthesis. *Synthesis* **2005**, 1-16.
247. Lynch, T. J.; Newcomb, M.; Bergbreiter, D. E.; Hall, M. B., Molecular structure of the lithium enolate of acetaldehyde. *Journal of Organic Chemistry* **1980**, *45*, 5005-6.

248. Crouch, I. T.; Neff, R. K.; Frantz, D. E., Pd-Catalyzed Asymmetric β -Hydride Elimination en Route to Chiral Allenes. *Journal of the American Chemical Society* **2013**, *135*, 4970-4973.
249. Ma, S.; Tsui, H.-W.; Spinelli, E.; Busacca, C. A.; Franses, E. I.; Wang, N.-H. L.; Wu, L.; Lee, H.; Senanayake, C.; Yee, N.; Gonella, N.; Fandrick, K.; Grinberg, N., Insights into chromatographic enantiomeric separation of allenes on cellulose carbamate stationary phase. *Journal of Chromatography A* **2014**, *1362*, 119-128.
250. Periasamy, M.; Sanjeevakumar, N.; Dalai, M.; Gurubrahamam, R.; Reddy, P. O., Highly enantioselective synthesis of chiral allenes by sequential creation of stereogenic center and chirality transfer in a single pot operation. *Organic Letters* **2012**, *14*, 2932-2935.
251. Leiminer, A.; Stephan, B.; Mannschreck, A., Chiral 2H-pyrans. Part 4. The enantiomers of indolino spiro compounds. Barriers to thermal cleavage of their C(sp³)-O bond. *Molecular Crystals and Liquid Crystals Science and Technology, Section A: Molecular Crystals and Liquid Crystals* **1994**, *246*, 215-21.
252. Lorenz, K.; Yashima, E.; Okamoto, Y., Enantiomeric enrichment of stereolabile chiral spiro compounds by dynamic HPLC on chiral stationary phases. *Angewandte Chemie, International Edition* **1998**, *37*, 1922-1925.
253. Bringmann, G.; Mortimer, A. J. P.; Keller, P. A.; Gresser, M. J.; Garner, J.; Breuning, M., Atroposelective synthesis of axially chiral biaryl compounds. *Angewandte Chemie, International Edition* **2005**, *44*, 5384-5427.

254. Yamada, S.; Akimoto, H., The clear establishment of the absolute configurations in biphenyl, bianthryl, and bianthraquinonyl systems. *Tetrahedron Letters* **1968**, 3967-70.
255. Zhou, A.; Rayabarapu, D.; Hanson, P. R., "Click, click, cyclize": a DOS approach to sultams utilizing vinyl sulfonamide linchpins. *Organic Letters* **2009**, *11*, 531-534.
256. Martin, R. H., The helicenes. *Angewandte Chemie* **1974**, *86*, 727-38.
257. Shen, Y.; Chen, C.-F., Helicenes: Synthesis and Applications. *Chemical Reviews (Washington, DC, United States)* **2012**, *112*, 1463-1535.
258. Hauke, C. M.; Rahe, P.; Nimmrich, M.; Schuette, J.; Kittelmann, M.; Stara, I. G.; Stary, I.; Rybacek, J.; Kuehnle, A., Molecular Self-Assembly of Enantiopure Heptahelicene-2-Carboxylic Acid on Calcite (10 $\bar{1}$ 4). *Journal of Physical Chemistry C* **2012**, *116*, 4637-4641.
259. El Abed, R.; Aloui, F.; Genet, J.-P.; Ben Hassine, B.; Marinetti, A., Synthesis and resolution of 2-(diphenylphosphino)heptahelicene. *Journal of Organometallic Chemistry* **2007**, *692*, 1156-1160.
260. Ernst, K.-H.; Neuber, M.; Grunze, M.; Ellerbeck, U., NEXAFS study on the orientation of chiral P-heptahelicene on Ni(100). *Journal of the American Chemical Society* **2001**, *123*, 493-495.
261. Buergi, T.; Urakawa, A.; Behzadi, B.; Ernst, K.-H.; Baiker, A., The absolute configuration of heptahelicene: a VCD spectroscopy study. *New Journal of Chemistry* **2004**, *28*, 332-334.

262. Gingras, M., One hundred years of helicene chemistry. Part 1: non-stereoselective syntheses of carbohelicenes. *Chemical Society Reviews* **2013**, *42*, 968-1006.
263. Kamikawa, K., Recent development of helicene synthesis. *Yuki Gosei Kagaku Kyokaishi* **2014**, *72*, 58-67.
264. Gingras, M., One hundred years of helicene chemistry. Part 3: applications and properties of carbohelicenes. *Chemical Society Reviews* **2013**, *42*, 1051-1095.
265. Neese, F., The ORCA program system. *Wiley Interdisciplinary Reviews: Computational Molecular Science* **2012**, *2*, 73-78.
266. Perdew, J. P.; Burke, K.; Ernzerhof, M., Generalized gradient approximation made simple. *Physical Review Letters* **1996**, *77*, 3865-3868.
267. Becke, A. D., Density-functional thermochemistry. III. The role of exact exchange. *Journal of Chemical Physics* **1993**, *98*, 5648-52.
268. Weigend, F.; Ahlrichs, R., Balanced basis sets of split valence, triple zeta valence and quadruple zeta valence quality for H to Rn: Design and assessment of accuracy. *Physical chemistry chemical physics : PCCP* **2005**, *7*, 3297-305.
269. Klamt, A.; Schueuermann, G., COSMO: a new approach to dielectric screening in solvents with explicit expressions for the screening energy and its gradient. *Journal of the Chemical Society, Perkin Transactions 2: Physical Organic Chemistry (1972-1999)* **1993**, 799-805.

270. Chandrasekhar, S.; Mukherjee, S., A convenient modification of the Fischer indole synthesis with a solid acid. *Synthetic Communications* **2015**, *45*, 1018-1022.
271. Rogers, C. U.; Corson, B. B., One-step synthesis of 1,2,3,4-tetrahydrocarbazole and 1,2-benzo-3,4-dihydrocarbazole. *Journal of the American Chemical Society* **1947**, *69*, 2910-11.
272. Sharp, G., LARGE DOSES OF STRYCHNINE IN SURGICAL SHOCK. *The Lancet* **1902**, *159*, 1210.
273. Anthony, W. C., Reactions of 3, α -epoxyoxindoles and their rearrangement to 2,3-disubstituted indoles. *Journal of Organic Chemistry* **1966**, *31*, 77-81.
274. Shirinian, V. Z.; Belen'kii, L. I.; Krayushkin, M. M., A convenient method for the preparation of N-unsubstituted hydrazones of aromatic ketones and aldehydes. *Russian Chemical Bulletin (Translation of Izvestiya Akademii Nauk, Seriya Khimicheskaya)* **1999**, *48*, 2171-2173.
275. Rad, M. N. S.; Khalafi-Nezhad, A.; Asrari, Z.; Behrouz, S.; Amini, Z.; Behrouz, M., One-pot synthesis of sulfonamides from primary and secondary amine derived sulfonate salts using cyanuric chloride. *Synthesis* **2009**, 3983-3988.
276. Raban, M.; Jones, F. B., Jr., Stereochemistry at trivalent nitrogen. XI. Effect of polar substituents on the barrier to rotation about the sulfenyl sulfur-nitrogen bond in N-alkyl-N-arenesulfonylarenesulfenamides. *J. Amer. Chem. Soc.* **1971**, *93*, 2692-9.

12. LIST OF PUBLISHED PAPERS AND CONFERENCE PRESENTATIONS

Research Papers [Published]

- 1 Novel Formation of $[2M-H]^+$ Species in Positive Electrospray Mass Spectra of Indoles, A Sadykhan, S T Ayrton, R T Gallagher, W H C Martin and R D Bowen, Rapid Commun Mass Spectrom, 2014, **26**, 1948-1952.
- 2 Intra-molecular N-C Rearrangements involving Sulfonamide Protecting Groups, Nitrogen to Carbon Rearrangement forming Nictonic Acid Sulfonamides, A Sadykhan, R D Bowen, R T Gallagher and W H C Martin, Tetrahedron Lett, 2015, 66-68.

Research Papers [Submitted or in Preparation]

- 3 The Mechanism of Alkene Elimination from Protonated Toluenesulphonamides generated by Electrospray Ionisation, A Sadykhan, J Ebert, W H C Martin, R T Gallagher and R D Bowen, submitted.
- 4 Mass spectra of oxo-cycloalkan[*b*]indoles, A Sadykhan, W H C Martin, R T Gallagher and R D Bowen, in preparation.
- 5 Detection and Characterisation of Oxocyclohexan[*b*]indoles by Combined Application of Vibrational Spectroscopy and Mass Spectrometry, A Sadykhan, W H C Martin, R T Gallagher, J Kendrick and R D Bowen, in preparation

Conference Presentations [* indicates presenter was A Saidykhan; † indicates poster presentation; † indicates oral presentation.]

- 1* Mass Spectrometry of Tricyclic Indoles, A Saidykhan, R D Bowen, H G M Edwards and R T Gallagher, 32nd British Mass Spectrometry Society Meeting, University of Cardiff, September 2011 (poster 4).
- 2 Mass Spectra of Tricyclic Indoles, Ketoindoles and Indolenines, S T Ayrton, A Saidykhan, R D Bowen, W H C Martin and R T Gallagher, 33rd BMSS, AstraZeneca, Alderley Park, April 2012.
- 3* Mass Spectrometry of Tricyclic Indoles, A Saidykhan, R D Bowen, W H C Martin and R T Gallagher, Royal Society of Chemistry Postgraduate Symposium, University of Bradford, October 2012.
- 4 Covalent Dimerisation of Protonated Indole Analogues under ESI+ Conditions, S T Ayrton, A Saidykhan, R D Bowen, W H. C Martin and R T Gallagher, British Mass Spectrometry Society Meeting 80-60 conference, University of Warwick, December 2012.
- 5 Covalent Dimerisation of Protonated Indole Analogues under ESI+ Conditions, R T Gallagher, S T Ayrton, A Saidykhan, W H C Martin and R D Bowen, 61st American Society for Mass Spectrometry Meeting, Minneapolis, USA, June 2013.
- 6 Mass Spectra of Benzanilides, Y Nazir, A Saidykhan, K S Jagdev, W H C Martin, R D Bowen and R T Gallagher, 34th British Mass Spectrometry Society Meeting, Eastbourne, UK, September 2013.
- 7* Covalent Dimerisation of Protonated Indole Analogues under ESI+ Conditions, A Saidykhan, R T Gallagher, S T Ayrton, W H C Martin and R D Bowen, 34th British Mass Spectrometry Society Meeting, Eastbourne, UK, September 2013.

- 8* Bond formation in the Nebuliser of an ESI+ Instrument - Analytical Applications and Scope for Synthesis, S T Ayrton, R D Bowen, R T Gallagher, W H C Martin and A Sadykhan, 35th British Mass Spectrometry Society Meeting, AstraZeneca, Alderley Park, April 2014.
- 9*.† Novel Dimerisation of Indoles under Positive Ion Electrospray Conditions, A Sadykhan, S T Ayrton, R D Bowen, W H C Martin and R T Gallagher, Royal Society of Chemistry Postgraduate Symposium, University of Bradford, October 2014.
- 10 Interesting Rearrangement Chemistry of Sulphonamides, A Sadykhan, R D Bowen, R T Gallagher and W H C Martin, Royal Society of Chemistry Postgraduate Symposium, University of Bradford, October 2014.
- 11* Novel Formation of $[2M-H]^+$ Covalent Dimers from Indoles under ESI+ Conditions, S T Ayrton, A Sadykhan, W H C William, R T Gallagher and R D Bowen, 36th British Mass Spectrometry Society Meeting, University of Birmingham, September, 2015.