

bradscholars

Bond between glass fibre reinforced polymer bars and high - strength concrete

Item Type	Article
Authors	Saleh, N.;Ashour, Ashraf;Sheehan, Therese
Citation	Saleh N, Ashour A, Sheehan T (2019) Bond between glass fibre reinforced polymer bars and high-strength concrete. Structures. 22: 139-153.
DOI	https://doi.org/10.1016/j.istruc.2019.08.003
Publisher	Elsevier
Rights	© 2019 Institution of Structural Engineers. Published by Elsevier Ltd. All rights reserved. Reproduced in accordance with the publisher's self-archiving policy. This manuscript version is made available under the CC-BY-NC-ND 4.0 license.
Download date	2026-06-10 03:55:19
Link to Item	http://hdl.handle.net/10454/17246

Bond between glass fibre reinforced polymer bars and high - strength concrete

Najia Saleh^{a*}, Ashraf Ashour^b and Therese Sheehan^b

^a Civil Engineering Department, University of Omar Al-Mukhtar, Al Baida, Libya

^b School of Engineering, University of Bradford, Bradford, BD7 1DP, UK

E-mails: obeidinajia@hotmail.com,

a.f.ashour@bradford.ac.uk, T.sheehan@bradford.ac.uk

ABSTRACT

In this study, bond properties of glass fibre reinforced polymer (GFRP) bars embedded in high-strength concrete (HSC) were experimentally investigated using a pull-out test. The experimental program consisted of testing 84 pull-out specimens prepared according to ACI 440.3R-12 standard. The testing of the specimens was carried out considering bar diameter (9.5, 12.7 and 15.9 mm), embedment length (2.5, 5, 7.5 and 10 times bar diameter) and surface configuration (helical wrapping with slight sand coating (HW-SC) and sand coating (SC)) as the main parameters. Twelve pull-out specimens reinforced with 16 mm steel bar were also tested for comparison purposes.

Most of the specimens failed by a pull-out mode. Visual inspection of the tested specimens reinforced with GFRP (HW-SC) bars showed that the pull-out failure was due to the damage of outer bar surface, whilst the detachment of the sand coating was responsible for the bond failure of GFRP (SC) reinforced specimens. The bond stress – slip behaviour of GFRP (HW-SC) bars is different from that of GFRP (SC) bars and it was also found that GFRP (SC) bars gave a better bond performance than GFRP (HW-SC) bars. It was observed that the reduction rate of bond strength of both GFRP types with increasing the bar diameter and the embedment length was reduced in the case of high-strength concrete. Bond strength predictions obtained from ACI-440.1R, CSA-S806, CSA-S6 and

29 JSCE design codes were compared with the experimental results. Overall, all design
30 guidelines were conservative in predicting bond strength of both GFRP bars in HSC and
31 ACI predictions were closer to the tested results than other codes.

32 Keywords: GFRP bar; high-strength concrete; pull-out; bond behaviour and design code

33 **1 Introduction**

34 The use of fibre reinforced polymer (FRP) re-bars as an alternative to steel reinforcement
35 has rapidly increased because of their excellent corrosion resistance, high tensile strength
36 to weight ratio, good non-magnetisation properties, good fatigue properties and ease of
37 handling. However, FRP reinforced concrete members behave differently to those
38 reinforced with steel bars due to non- ductility of FRP bars, lower modulus of elasticity and
39 bond strength which influence the performance of FRP reinforced concrete members. The
40 mechanism of bond stress transfer between FRP bars and concrete is a fundamental
41 requirement to guarantee their successful application in concrete members. In addition,
42 the use of high-strength concretes has been recently increased owing to their higher
43 compressive and tensile strengths, better durability and higher stiffness than normal-
44 strength concretes. Many studies have been conducted to investigate the bond behaviour
45 of GFRP bars in normal-strength concrete (NSC) using a pull-out test [1-10]. However,
46 very limited research studies are available in the literature regarding the bond behaviour
47 of GFRP bars embedded in high- strength concrete using a pull-out method [5, 10-15].
48 Baena et al. [5] tested pull-out specimens reinforced with GFRP bars having various
49 surface treatments (sand coating, helical wrapping with a slight sand coating and grooves)
50 and concrete compressive strengths (30 and 50 MPa). They confirmed that different bond
51 mechanisms were observed for different surface configurations. Moreover, the effect of
52 surface treatment on bond strength was less significant for concretes with low

53 compressive strengths, but it was important for concretes with high-compressive strengths
54 [\[5\]](#). The influence of two types of GFRP bar (sand coating and helical wrapping with a
55 slight sand coating) on the bond performance was also investigated by Davalos et al. [\[11\]](#)
56 considering concrete compressive strength in the range of 57 to 63 MPa. They found that
57 sand coated GFRP bars had better bond strength than helically wrapped GFRP bars. On
58 the contrary, the results obtained by Lee et al. [\[12\]](#) indicated that the bond strength for the
59 helically wrapped with slightly sand coated GFRP bars was higher than that for the sand
60 coated GFRP bars for concrete compressive strengths (25, 40 and 70 MPa). Hossain et
61 al. [\[13\]](#) tested the bond behaviour of sand-coated GFRP bars in HSC (74 MPa) with taking
62 into account two the effect of two parameters: bar diameter (15.9 and 19.1 mm) and
63 embedment length (3, 5, 7, 10 times bar diameter). Their findings showed that the
64 reduction in bond strength with increasing bar diameter was clear for each embedment
65 length. It was also observed that the decrease rate in bond strength reduced, as the
66 embedment length increased. Furthermore, the experimental investigation performed by
67 Tekle et al. [\[14\]](#) indicated that the increase of the embedment length of sand-coated GFRP
68 bars embedded in HSC (42 MPa) resulted in reducing in the bond strength. Lee et al. [\[15\]](#)
69 investigated the effect of bar diameter (19 and 25 mm) on the bond behaviour of two types
70 of GFRP bars (sand-coated and spiral-wrapped) in high -strength concrete (40 and 60
71 MPa). It was found that a reduction rate in bond strength for both GFRP types was lower
72 with increasing the bar size. Lee et al. [\[10\]](#) studied the influence of concrete strength on
73 the bond failure mode of helically wrapped and sand coated GFRP bars. They found that
74 bond failure occurred at the interface between concrete and outer bar surface for normal
75 strength concrete, while it occurred at the interface between outer bar surface and bar
76 core in the case of high-strength concrete. They also found that bond strength increased

77 with increasing the concrete strength (from 25.6 to 92.4 MPa) and this improvement in
78 bond strength was greater in steel bars than in GFRP bars. As a result, the investigation
79 of bond properties of GFRP bars in HSC with considering the effect of bar diameter,
80 embedment length and bar surface has not been adequately covered in the literature.
81 Therefore, further research needs to be conducted.

82 According to the previous experimental investigations [\[1, 2, 4, 5, 16-20\]](#), it was found that
83 bond strength of GFRP bars in conventional concrete depends on several parameters,
84 such as bar diameter, embedment length, compressive concrete strength, surface
85 configuration, bar type, concrete cover, bar position and transverse reinforcement. Table
86 1 summarizes the parameters that influence the bond strength considered in the design
87 guidelines (ACI 440.1R [\[21\]](#), CSA-S806 [\[22\]](#), CSA-S6 [\[23\]](#) and JSCE [\[24\]](#)). The key
88 factors, namely concrete strength, bar diameter, concrete cover and bar position, are
89 considered in all of these codes. Embedment length is only taken into account by ACI-
90 440.1R-15. The bar surface is one of the main factors which affects bond strength,
91 however, Canadian codes only considered this influence by suggesting the bar surface
92 factor in their equations. Although each FRP type has different bond characteristics, all
93 codes neglected the effect of fibre type on bond strength, except the Canadian codes.
94 Furthermore, confinement provided by transverse reinforcement (stirrups) along the*
95 developed and spliced reinforcing bars, that contributes in increasing bond strength, is
96 considered by Japanese and Canadian (CSA-S6) codes, and it is ignored in other codes.
97 The performance of code equations in predicting the bond strength of GFRP (HW-SC)
98 and GFRP (SC) re-bars embedded in high - strength concrete needs to be investigated.
99 In this paper, the results of 84 pull-out tests performed according to ACI 440.3R-12 [\[25\]](#)
100 are presented with the aim of better understanding the bond properties of two common

101 GFRP bar types (helical wrapping with a slight sand coating and sand coating) in high –
 102 strength concrete. The bond behaviour is analysed considering the effect of the following
 103 parameters (embedment length, bar diameter and surface configuration) on bond
 104 strength. The code predictions are compared with the test results for validating their
 105 applicability in the case of high – strength concrete.

106 **Table 1 - Main factors considered in determining bond strength by design codes**

Model	Bar diameter	Concrete strength	Concrete cover	Bar surface	Bar location	Bonded length	Transverse reinforcement	Fibre type
JSCE 1997	✓	✓	✓	x	✓	x	✓	x
CSA-S806-12	✓	✓	✓	✓	✓	x	x	✓
CSA-S6-14	✓	✓	✓	✓	✓	x	✓	✓
ACI 440.1R-15	✓	✓	✓	x	✓	✓	x	x

107

108 **2 Experimental investigation**

109 **2.1 Materials**

110 Pull-out cubes were constructed using ready – mixed concrete with a maximum coarse
 111 aggregate size of 10 mm. Cylinder specimens (150 x 300 mm) and cube specimens (100
 112 x 100 x 100 mm) were cast and cured under the same conditions as pull-out cubes. The
 113 cylinders and cubes were tested immediately after testing the pull-out specimens to
 114 provide the splitting tensile strength and the cube compressive strength of concrete.
 115 GFRP (HW-SC), GFRP (SC) and steel bars were used in this study. Helically wrapped
 116 with slightly sand coated GFRP and sand coated GFRP bars shown in Figure 1 were
 117 made of continuous longitudinal fibres impregnated in vinylester resin: the minimum
 118 content of continuous ECR-glass fibres was 75% (per weight) and the maximum content
 119 of vinylester resin was 25%, and the content of continuous E-glass fibres 80% (per unit
 120 weight) and vinylester resin 20%, respectively. The tensile strength and elastic modulus
 121 of GFRP and steel bars were determined according to specifications ASTM

122 D7205/D7205M [26] and ASTM A706/A706M [27], respectively. The outer diameters were
 123 measured according to ACI 440.3R-12 [25]. The geometrical and mechanical properties
 124 of GFRP and steel bars are summarized in Table 2, and the mechanical properties of
 125 vinylester resin are shown in Table 3.

126

Table 2. Geometrical and mechanical properties of GFRP and steel bars

Bar type	GFRP (HW-SC)			GFRP (SC)			Steel
	3#	4#	5#	3#	4#	5#	
Bar size	3#	4#	5#	3#	4#	5#	5#
Nominal diameter (mm)	9.5	12.7	15.9	9.5	12.7	15.9	16
Measured diameter (mm)	10.76	13.44	16.76	10.4	13.33	16.74	-
Tensile strength (MPa)	827 (940.2)	758 (797)	724 (867.9)	1227.3 (1224.6)	1375 (1175.4)	1373.7 (1210.3)	672 (666)
Ultimate strain (%)	1.79	1.64	1.57	2.4	2.7	2.7	-
Elastic modulus (GPa)	46 (51.7)	46 (49.7)	46 (46.9)	50 (50.98)	51 (51.57)	51 (52.15)	200 (199)
Yielding strength (MPa)	-	-	-	-	-	-	582 (569)

127
 128
 129
 130

The values between brackets measured in the laboratory are the average of three samples, whereas other values are provided by the manufacturer.

Table 3. Mechanical properties of vinylester resin

Bar type	Flexural Strength (MPa)	Flexural Modulus (MPa)	Tensile Strength (MPa)	Tensile Elongation (%)	Tensile Modulus (MPa)
GFRP (HW-SC)	144	3500	84	4.2	3400
GFRP (SC)	156	3172	90	4.2	3586

131
 132



133
 134
 135
 136

(a) Helically wrapped with sand coated surface (type A)



(b) Sand coated surface (type B)

Figure 1. Surface configurations of GFRP re-bars

137
138
139
140
141
142

143 2.2 Test specimens

144 Seventy-two GFRP and twelve steel reinforced cubes were tested. The parameters
145 investigated were bar diameter (9.5, 12.7 and 15.9 mm for GFRP and 16 mm for steel)
146 and embedment length (2.5, 5, 7.5 and 10 times bar diameter). The geometrical details of
147 the pull-out cubes are given in Figure 2. The un-bonded length was covered by a PVC
148 tube to prevent contact between the bar and the concrete. The concrete mix (C1) was
149 used to cast cubes reinforced with GFRP (type A) and steel reinforced concrete cubes
150 having embedment lengths $2.5d_b$ and $5d_b$. Specimens reinforced with GFRP (type B) and
151 those reinforced with steel bars having embedment lengths $7.5d_b$ and $10d_b$ were cast
152 using the second batch (C2). Before casting, the inner sides of the moulds were covered
153 by a thin film of oil to allow demoulding of the specimens. The concrete was placed in
154 three layers and each layer was vibrated using a poker vibrator. After casting, all
155 specimens were covered with a polythene sheet to prevent evaporation of water from the
156 unhardened concrete until demoulding. After one week, the specimens were demoulded,
157 marked, covered with a polythene sheet and stored in a temperature-controlled laboratory
158 until testing.

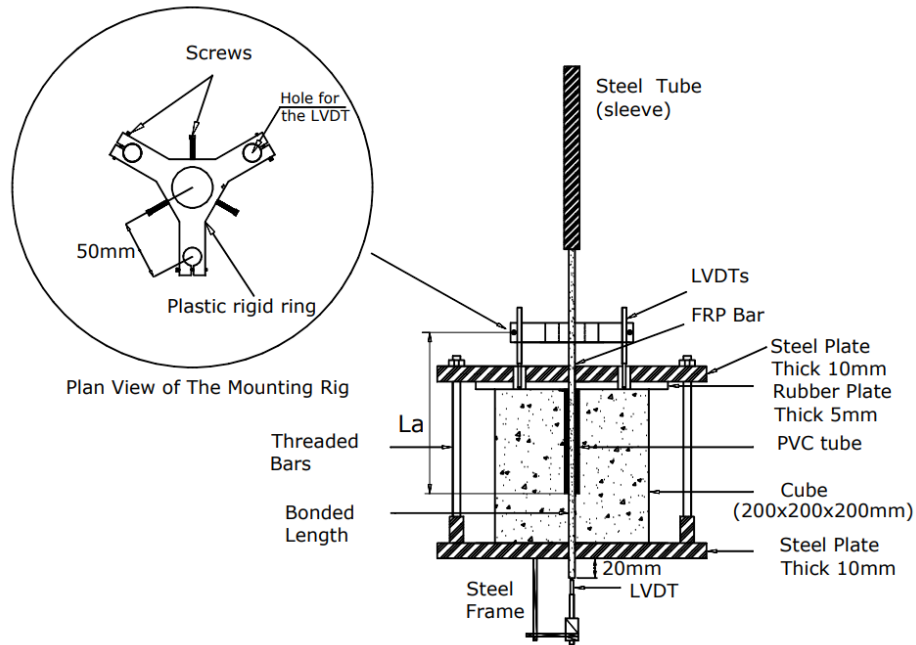
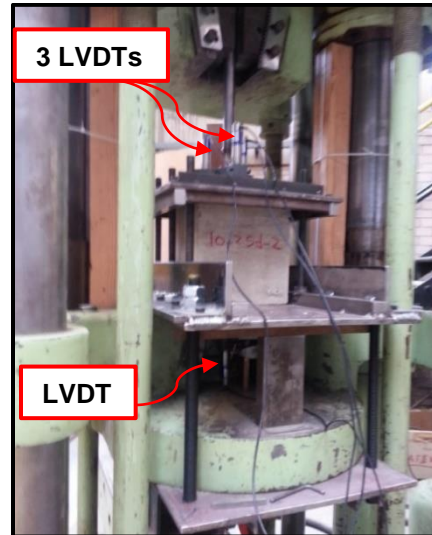

Figure 2. Pull-out test arrangement

2.3 Experimental set-up

The pull-out test set-up is shown in Figure 3. The specimen was placed in a specially made steel frame that was positioned in the testing machine. Three linear variable displacement transducers (LVDTs) were connected to the bar by a plastic rigid rig and touched the top surface of the specimen to measure the loaded end slip. Only one LVDT was attached to a small steel frame which was fixed to the below surface of the concrete cube to measure the free end slip. Small irregularities at the top surface of the cube might result in accidental bending of the bar during loading or movements caused by local crushing. Therefore, a 5-mm-thick rubber plate was introduced to secure the contact between the top surface of the concrete block and the steel bearing plate. The tensile load was applied directly to the bar using a testing machine of 500 kN capacity. The loading rate was changed for each 15 mm of head movement of the machine to be 0.02, 0.05 and 0.1 mm/sec, respectively. The reason for increasing the loading rate was to accelerate

174 the test after the occurrence of pull-out failure. The displacement-control mode was
175 selected to record the post-peak curve. Applied load and LVDT readings were
176 automatically recorded using the data logging system.



177
178 **Figure 3. Pull-out test set-up**

179 **3 Test results and discussion**

180 Three identical specimens for each configuration were tested. The bond stress - slip
181 relationships were developed and plotted using measured data. The bond stress is
182 defined by equation 1.

$$183 \quad \tau = \frac{F}{\pi d_b l_e} \quad (1)$$

184 where τ is the bond stress (N/mm²); F is the applied tensile load (N); d_b is the bar diameter
185 (mm) and l_e is the embedment length (mm). As the three LVDTs readings at the loaded
186 end of the bar covered both the loaded end slip and the elastic elongation of the bar above
187 the embedment length (L_a) (see Figure 2), therefore, the loaded end slip (s_{le}) is calculated
188 by subtracting the LVDT measurement (s_{total}) from the bar extension (s_e) as illustrated in
189 equations 2 and 3:
190

191
$$s_{le} = s_{total} - s_e \quad (2)$$

192
$$s_e = \frac{F \cdot L_a}{A_b \cdot E_{frp}} \quad (3)$$

193 where A_b is the cross-sectional area of bar (mm^2), L_a is the length from the LVDTs support
 194 point to the top surface of the bonded bar (mm) (see Figure 2) and E_{frp} is the elastic
 195 modulus of the bar (MPa). The displacement at the unloaded end of bar was directly
 196 obtained from the slip measurement of the bottom LVDT. The maximum applied load
 197 (F_{max}), the maximum bond strength (τ_{max}) with the corresponding loaded end slip (s_{le}) and
 198 unloaded end slip (s_{ul}), failure mode, the average compressive strength of four concrete
 199 cubes (f_{cu}) and average splitting tensile strength of three concrete cylinders (f_t) are
 200 presented for specimens reinforced with type A and type B in Tables 4 and 5, respectively.
 201 The mean values of bond strength (τ_{avg}) and the corresponding loaded end and free end
 202 slips ($s_{le,m}$ and $s_{ul,m}$) (obtained as an average of the results of three identical specimens)
 203 are also reported. The cube compressive strength of concrete C1 was in the range of
 204 97.38 to 102.36 MPa with an average of 100.17 MPa and a coefficient of variation (COV)
 205 of 2.4%. As for concrete C2, it changed from 77.47 to 83.07 MPa with an average of 79.24
 206 MPa and a COV of 2.9%. The average splitting tensile strength of concrete C1 and C2
 207 obtained from testing three cylinders varied from 4.13 MPa to 4.71 MPa with an average
 208 of 4.34 MPa and a COV of 7.3% and changed from 3.24 MPa to 3.67 MPa with an average
 209 of 3.46 MPa and a COV of 6.2%, respectively. A small difference was observed among
 210 the bond strengths of the three identical cubes because of the non-homogenous nature
 211 of conventional concrete. The definition of specimen notation is as follows: the first letter
 212 denotes the bar type (A for GFRP (HW-SC), B for GFRP (SC) and C for steel); the first

213 number indicates the bar diameter; the second one denotes the embedment length and
 214 the last number refers to the specimen number.

215 **Table 4. Experimental results of pull-out cubes reinforced with GFRP (HW-SC) bars in concrete C1**

Specimen label	f_{cu} (MPa)	f_t (MPa)	F_{max} (kN)	τ_{max} (MPa)	S_{ul} (mm)	S_{le} (mm)	τ_{avg} (MPa)	$S_{ul,m}$ (mm)	$S_{le,m}$ (mm)	Failure Mode
A-9.5-2.5d-1	97.38	4.13	14.95	21.09	0.434	0.531				PO
A-9.5-2.5d-2	97.38	4.13	14.11	19.9	0.193	0.228	20.55	0.306	0.416	PO
A-9.5-2.5d-3	97.38	4.13	14.64	20.66	0.291	0.490				PO
A-9.5-5d-1	97.38	4.13	28.47	20.08	0.124	0.378				PO
A-9.5-5d-2	97.38	4.13	27.83	19.63	0.391	0.659	20.08	0.211	0.448	PO
A-9.5-5d-3	97.38	4.13	29.11	20.53	0.118	0.309				PO
A-9.5-7.5d-1	97.38	4.13	The testing machine suddenly stopped before debonding failure							
A-9.5-7.5d-2	97.38	4.13	41.98	19.73	0.104	1.127	19.76	0.106	0.898	PO
A-9.5-7.5d-3	97.38	4.13	42.1	19.79	0.108	0.67				PO
A-9.5-10d-1	97.38	4.13	55.7	19.65	0.411	1.486				PO
A-9.5-10d-2	97.38	4.13	55.3	19.49	0.659	1.477	19.27	0.621	1.620	PO
A-9.5-10d-3	97.38	4.13	53	18.68	0.793	1.897				PO
A-12.7-2.5d-1	97.72	4.19	28.26	22.3	0.407	0.436				PO
A-12.7-2.5d-2	97.72	4.19	23.01	18.16	0.75	0.80	19.79	0.486	0.547	PO
A-12.7-2.5d-3	97.72	4.19	23.95	18.90	0.301	0.405				PO
A-12.7-5d-1	97.72	4.19	41.15	16.24	6.94	7.03				PO
A-12.7-5d-2	97.72	4.19	40.61	16.02	5.99	6.151	16.13	—*	—*	PO
A-12.7-5d-3	97.72	4.19	40.86	16.13	6.387	6.446				PO
A-12.7-7.5d-1	97.72	4.19	61.60	16.20	0.506	1.338				PO
A-12.7-7.5d-2	97.72	4.19	59.04	15.53	0.736	1.139	16.71	0.679	1.215	PO
A-12.7-7.5d-3	97.72	4.19	69.90	18.39	0.797	1.169				PO
A-12.7-10d-1	97.72	4.19	77.47	15.28	0.468	1.545				PO
A-12.7-10d-2	97.72	4.19	79.94	15.77	0.744	1.798	16.05	0.728	1.612	PO
A-12.7-10d-3	97.72	4.19	86.70	17.10	0.974	1.493				PO

A-15.9-2.5d-1	101.68	4.71	42.13	21.21	0.458	0.634				PO
A-15.9-2.5d-2	101.68	4.71	38.55	19.42	0.330	0.414	19.42	0.363	0.496	PO
A-15.9-2.5d-3	101.68	4.71	35	17.62	0.302	0.440				PO
A-15.9-5d-1	101.68	4.71	70.65	17.78	0.388	1.049				PO
A-15.9-5d-2	101.68	4.71	79.04	19.90	0.826	1.111	18.70	0.60	1.097	PO
A-15.9-5d-3	101.68	4.71	73.20	18.42	0.586	1.131				PO
A-15.9-7.5d-1	102.36	4.71	97.21	16.32	0.439	1.170				PO
A-15.9-7.5d-2	102.36	4.71	98.51	16.53	0.858	1.234	16.32	0.533	1.208	PO
A-15.9-7.5d-3	102.36	4.71	96.02	16.11	0.304	1.220				PO
A-15.9-10d-1	102.36	4.71	115.5	14.55	0.410	1.561				PO
A-15.9-10d-2	102.36	4.71	116.9	14.72	0.656	1.619	14.82	0.660	1.628	PO
A-15.9-10d-3	102.36	4.71	120.7	15.20	0.915	1.706				PO
C-16-2.5d-1	97.38	4.13	76.2	37.88	0.939	1.481				PO
C-16-2.5d-2	97.38	4.13	76.85	38.21	0.593	1.408	38	0.766	1.444	PO
C-16-5d-1	101.7	4.71	120.5	29.94	-	1.924				PO
C-16-5d-2	101.7	4.71	101.4	25.20	1.534	1.804	27.56	1.534	1.864	PO
C-16-5d-3	101.7	4.71	110.8	27.55	-	1.864				PO

216 Note: * indicates specimens exhibited an almost yield plateau until full slip without a clear peak bond
217 strength.

218 **Table 5. Experimental results of pull-out cubes reinforced with GFRP (SC) bars in concrete C2**

Specimen label	f_{cu} (MPa)	f_t (MPa)	F_{max} (kN)	τ_{max} (MPa)	S_{ul} (mm)	S_{1e} (mm)	τ_{avg} (MPa)	$S_{ul,m}$ (mm)	$S_{1e,m}$ (mm)	Failure Mode
B-9.5-2.5d-1	83.07	3.67	20.49	28.91	0.203	0.272				PO
B-9.5-2.5d-2	83.07	3.67	21.55	30.38	0.193	0.225	28.91	0.237	0.287	PO
B-9.5-2.5d-3	83.07	3.67	19.45	27.44	0.315	0.365				PO
B-9.5-5d-1	77.68	3.24	37.20	26.23	0.138	0.581				PO
B-9.5-5d-2	77.68	3.24	37.57	26.49	0.200	0.776	25.51	0.139	0.570	PO
B-9.5-5d-3	77.68	3.24	33.78	23.82	0.081	0.377				PO
B-9.5-7.5d-1	77.68	3.24	49.96	23.48	0.203	0.695				PO
B-9.5-7.5d-2	77.68	3.24	45.94	21.59	0.213	0.726	22.15	0.187	0.716	PO

B-9.5-7.5d-3	77.68	3.24	45.50	21.39	0.145	0.729				PO
B-9.5-10d-1	77.68	3.24	54	19.05	0.191	0.971				PO
B-9.5-10d-2	77.68	3.24	54.79	19.31	0.219	1.106	19.05	0.191	1.079	PO
B-9.5-10d-3	77.68	3.24	53.30	18.79	0.165	1.160				PO
B-12.7-2.5d-1	79.72	3.48	37.34	29.48	0.124	0.213				PO
B-12.7-2.5d-2	79.72	3.48	34.27	27.04	0.170	0.286	28.26	0.145	0.230	PO
B-12.7-2.5d-3	79.72	3.48	35.81	28.26	0.142	0.193				PO
B-12.7-5d-1	79.72	3.48	57.36	22.63	0.216	0.504				PO
B-12.7-5d-2	79.72	3.48	60.96	24.05	0.232	0.548	23.21	0.261	0.523	PO
B-12.7-5d-3	79.72	3.48	58.14	22.94	0.336	0.518				PO
B-12.7-7.5d-1	77.47	3.24	75.36	19.83	0.218	0.827				PO
B-12.7-7.5d-2	77.47	3.24	77.44	20.37	0.206	0.879	19.83	0.232	0.858	PO
B-12.7-7.5d-3	77.47	3.24	73.35	19.29	0.273	0.869				PO
B-12.7-10d-1	77.47	3.24	92.53	18.25	0.223	1.418				PO
B-12.7-10d-2	77.47	3.24	92.12	18.18	0.092	1.297	18.18	0.166	1.345	PO
B-12.7-10d-3	77.47	3.24	91.77	18.10	0.185	1.322				PO
B-15.9-2.5d-1	77.47	3.24	55.15	27.77	0.250	0.406				PO
B-15.9-2.5d-2	77.47	3.24	57.69	29.04	0.210	0.320	27.77	0.250	0.369	PO
B-15.9-2.5d-3	77.47	3.24	52.61	26.5	0.291	0.381				PO
B-15.9-5d-1	77.47	3.24	90.23	22.71	0.199	0.596				PO
B-15.9-5d-2	77.47	3.24	84.63	21.30	0.161	0.583	21.52	0.179	0.595	PO
B-15.9-5d-3	77.47	3.24	81.60	20.54	0.178	0.607				PO
B-15.9-7.5d-1	77.47	3.24	125.6	21.08	0.063	1.025				PO
B-15.9-7.5d-2	77.47	3.24	103.5	17.38	0.763	1.212	19.23	0.332	1.027	PO
B-15.9-7.5d-3	77.47	3.24	114.5	19.23	0.170	0.845				PO
B-15.9-10d-1	77.47	3.24	150.4	18.93	0.441	1.766				PO
B-15.9-10d-2	77.47	3.24	156.2	19.67	-	1.832	19.41	0.441	1.763	PO
B-15.9-10d-3	77.47	3.24	155.9	19.63	-	1.693				PO

C-16-7.5d-1	78.28	3.48	142	>23.54	0.281	0.646				Y
C-16-7.5d-2	78.28	3.48	142.7	>23.65	0.252	0.615	>23.1	0.199	0.587	Y
C-16-7.5d-3	78.28	3.48	134	>22.21	0.066	0.502				Y
C-16-10d-1	78.28	3.48	133.9	>16.64	0.495	0.758				Y
C-16-10d-2	78.28	3.48	131.3	>16.33	0.541	0.607	>16.60	0.446	0.740	Y
C-16-10d-3	78.28	3.48	135.4	>16.84	0.304	0.857				Y

219 Note: PO = Pull-out failure; SP = Splitting failure and Y = Bar yielding

220 (-) = Not measured (LVDT stopped)

221

222 3.1 Bond stress - slip relationship

223 The response of bond stress – loaded and unloaded end slips for each specimen is
 224 illustrated in Figures 4 to 6 for cubes reinforced with GFRP (type A) bars and Figures 7 to
 225 9 for GFRP (type B) reinforced cubes. The bond stress – slip curves for cubes reinforced
 226 with steel bars are also plotted in Figure 10. The bond stress – slip relationships are
 227 presented according to bar diameter, embedment length, surface characteristics and bar
 228 type to observe the influence of these main parameters on the bond behaviour in case of
 229 high-strength concrete.

230 The general trend of bond stress – slip curve for GFRP (HW-SC) bars is similar to that
 231 obtained by Lee et al. [12], Baena et al. [5], Davalos et al. [11], Okelo and Yuan [2] and
 232 Vint and Sheikh [28] from testing GFRP (HW-SC) reinforced specimens. In addition, the
 233 bond stress – slip behaviour for GFRP (SC) bars is similar to that reported by Vint and
 234 Sheikh [28], Baena et al. [5], Davalos et al. [11], Hossain et al. [13], El Refai et al. [7], Lee
 235 et al. [12], Antonietta Aiello et al. [29] and Arias et al. [30] from testing GFRP (SC)
 236 reinforced specimens.

237 The general behaviour of the bond stress – slip relationship is described by a high initial
 238 increase in bond stress without a significant slip in both GFRP types and steel bars due

239 to good chemical adhesion between the bar surface and the concrete. This stage
240 describes the initial stiffness. After the chemical adhesion resistance is lost, bond stress
241 continues to increase with increasing the applied load until the peak point, but the amount
242 of the slip increase is small. At this stage, bearing (undulations) and friction resistances
243 control to prevent de-bonding in GFRP (HW-SC) reinforced specimens. However, friction
244 resistance only dominates in specimens reinforced with GFRP (SC) bars and the
245 mechanical interlock only controls to resist the pull-out force in steel reinforced specimens.
246 In the descending stage (after bond failure), the bond stress reduces with increasing the
247 slip in both GFRP types, but the shape of the softening curve changes with differing
248 surface configuration. In specimens reinforced with helically wrapped and slightly sand
249 coated GFRP bars, bond stress degraded gradually with increasing the loaded and
250 unloaded end slips. It was noted that the reduction rate in residual bond stresses
251 increases with decreasing bar diameter as rib spacing of smaller diameter bars is larger
252 than that of higher diameter bars (rib spacings = 25, 23 and 20 mm with a constant rib
253 height for bar diameters = 9.5, 12.7 and 15.9 mm, respectively), indicating that residual
254 bond stresses depend on bar size. As for GFRP (type B) reinforced specimens, the bond
255 stress reduced suddenly to be almost zero with a strong slip accompanied with a loud
256 bang (relative brittle failure and significant energy release) due to detaching of the sand
257 coated layer. No data was recorded during that short moment. Then, bond stress started
258 to increase again up to a certain level, followed by an increase in the slip owing to the
259 remaining frictional resistance. The residual bond stresses produced in GFRP (SC)
260 reinforced specimens are lower than those produced in GFRP (HW-SC) reinforced
261 specimens due to loss of frictional resistance, when the sand coating layer was entirely
262 stripped, leading to a smooth surface. For steel reinforced cubes that failed in a pull-out

263 mode, the post-peak bond stresses reduced gradually similar to GFRP (HW-SC) bars,
264 however, the reduction was faster than the reduction in GFRP (HW-SC) reinforced
265 specimens owing to lower frictional resistance. The bond stress – slip behaviour of
266 specimens A-12.7-5d was different from other specimens reinforced with GFRP (HW-SC)
267 bars as specimens exhibited an almost yield plateau until full slip without a clear peak
268 bond strength, but similar to that obtained by Baena et al. [5] and Lee et al. [12] from
269 testing GFRP (HW-SC) reinforced specimens. This might be attributed to the wedging
270 action resulting from the crushed concrete sticking to the front of the ribs. From the bond
271 stress – slip curves (Figures 4 to 10), Tables 4 and 5, it can be noted that the loaded end
272 slip is higher than the unloaded end slip at the same pull-out load, indicating that the high
273 bond stress at the loaded end reduces gradually towards the unloaded end (non-linear
274 distribution).

275 The bond strength of GFRP (SC) bars is higher than that of GFRP (HW-SC) bars, but the
276 corresponding slip for GFRP (SC) bars is smaller than that for GFRP (HW-SC) bars,
277 indicating that bond properties of sand coated surfaces are better than those of the
278 helically wrapped surfaces, and the amount of slip is influenced by the bar surface. The
279 effect of surface configuration on the slip was confirmed by Lee et al. [12] and Pepe et al.
280 [31]. In addition, it is noticed that the loaded end slip corresponding to the maximum bond
281 stress increases with increasing embedment length for the same bar diameter in both
282 GFRP types and this was also reported by Pepe et al. [31] and Tekle et al. [14]. Steel
283 reinforced cubes having embedment lengths of 7.5 and 10 times the bar diameter were
284 failed by yielding as shown in Figure 10, because the pullout force exceeded the force
285 causing the bar fracture.

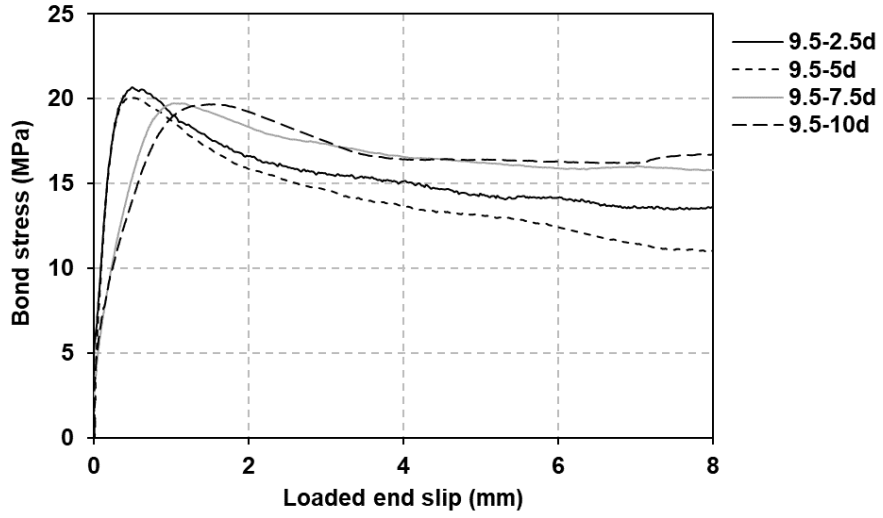

286

287

(a)

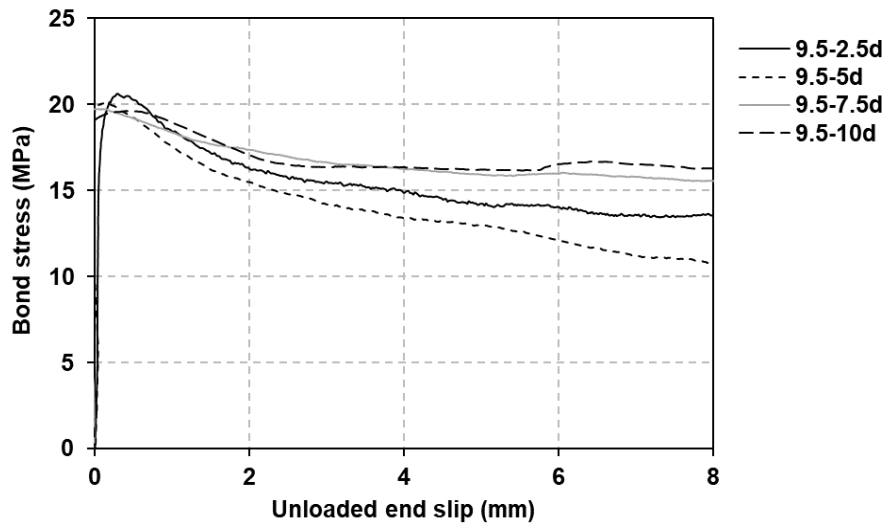

288

289

(b)

290 **Figure 4. Bond stress - slip relationship for 9.5 mm GFRP (type A) reinforced cubes: (a) loaded and**
 291 **(b) unloaded end slips**

292

293

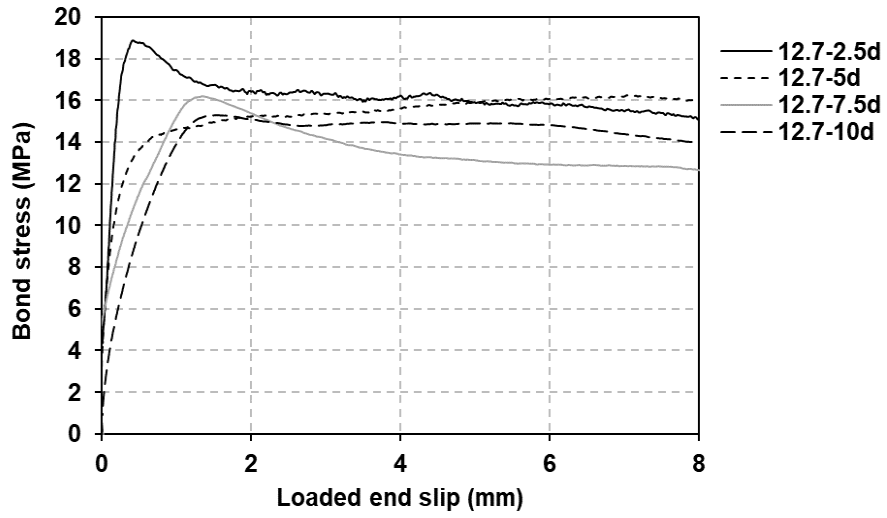

294

295

(a)

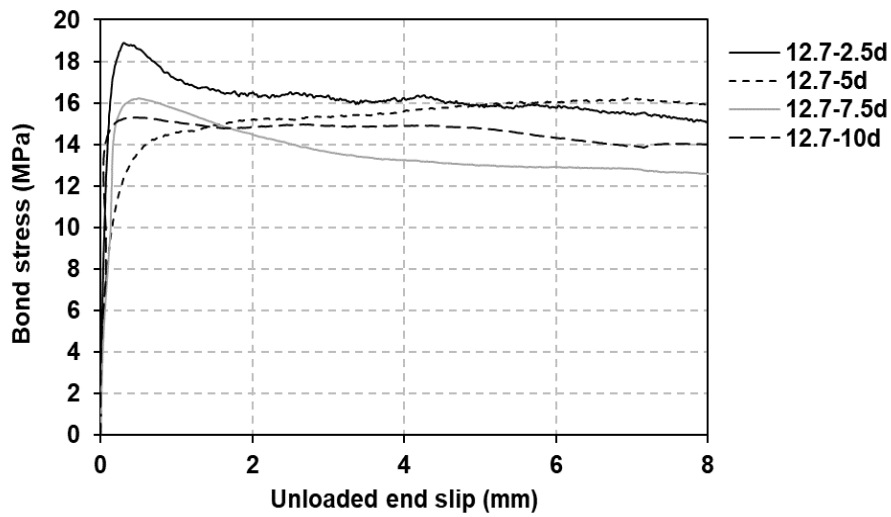

296

297

(b)

Figure 5. Bond stress - slip relationship for 12.7 mm GFRP (type A) reinforced cubes: (a) loaded and (b) unloaded end slips

298

299

300

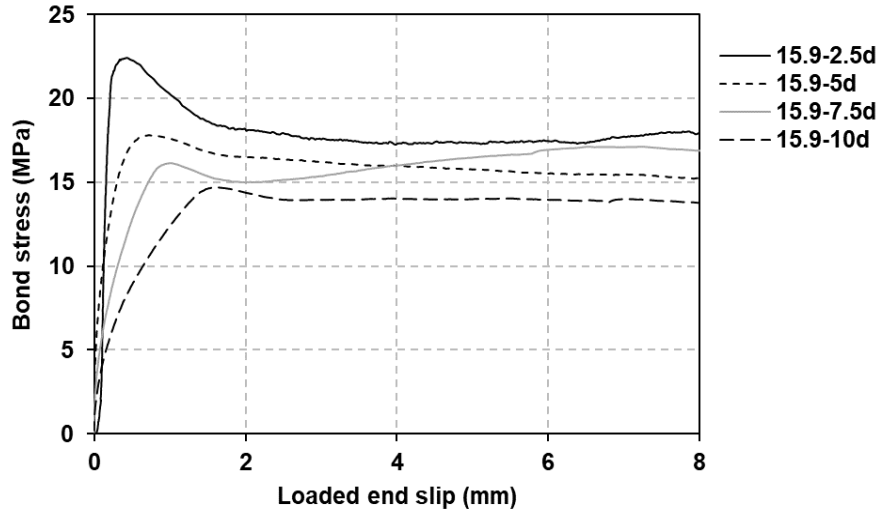

301

302

(a)

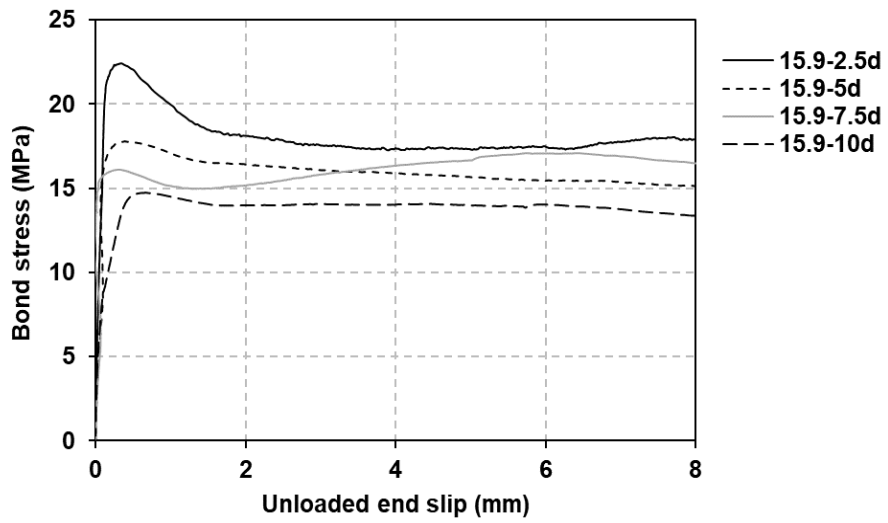

303

304

(b)

305 **Figure 6. Bond stress - slip relationship for 15.9 mm GFRP (type A) reinforced cubes: (a) loaded**
 306 **and (b) unloaded end slips**

307

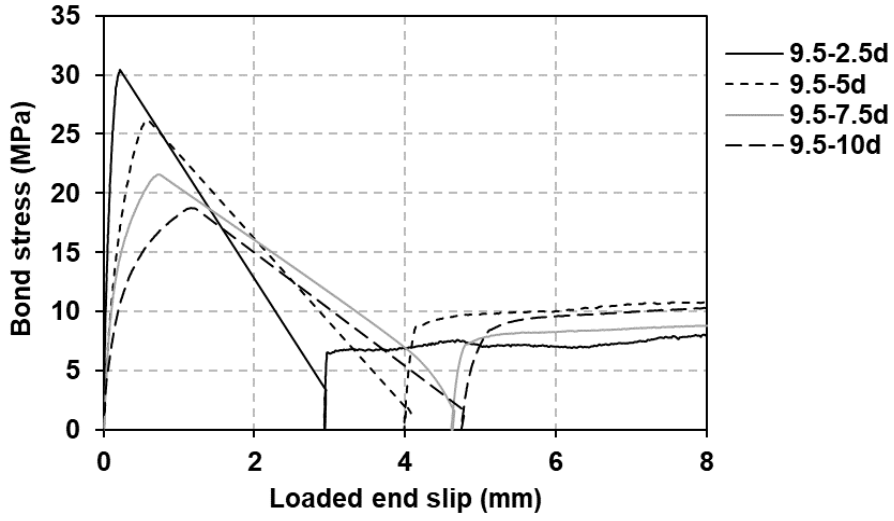

308

309

(a)

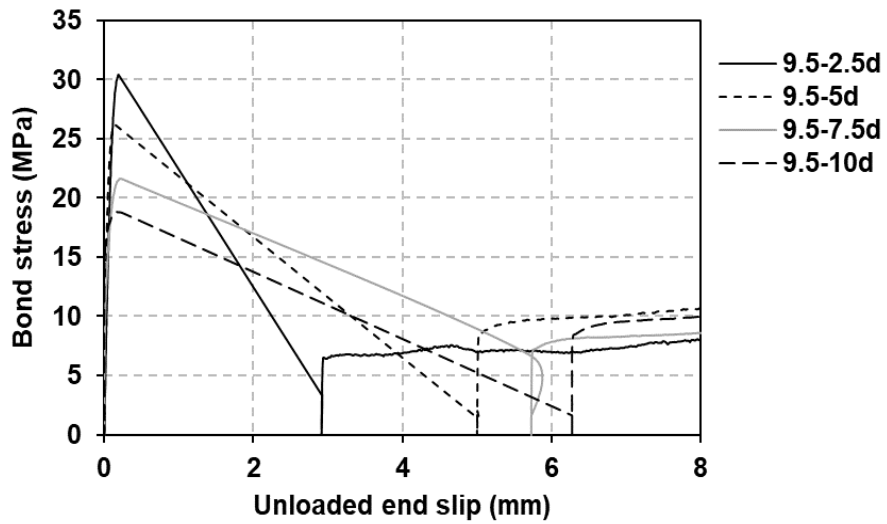

310

311

(b)

312 **Figure 7. Bond stress - slip relationship for 9.5 mm GFRP (type B) reinforced cubes: (a) loaded and**
 313 **(b) unloaded end slips**

314

315

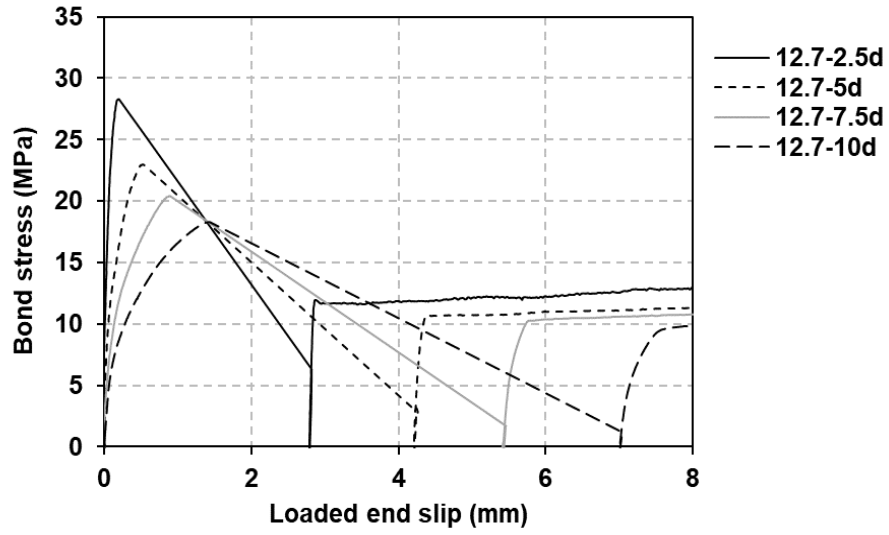

316

317

(a)

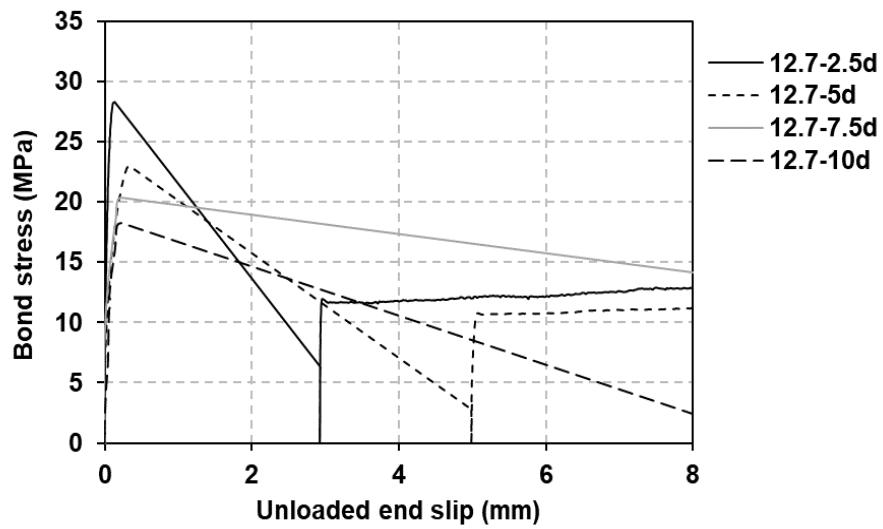

318

319

(b)

Figure 8. Bond stress - slip relationship for 12.7 mm GFRP (type B) reinforced cubes: (a) loaded and (b) unloaded end slips

320

321

322

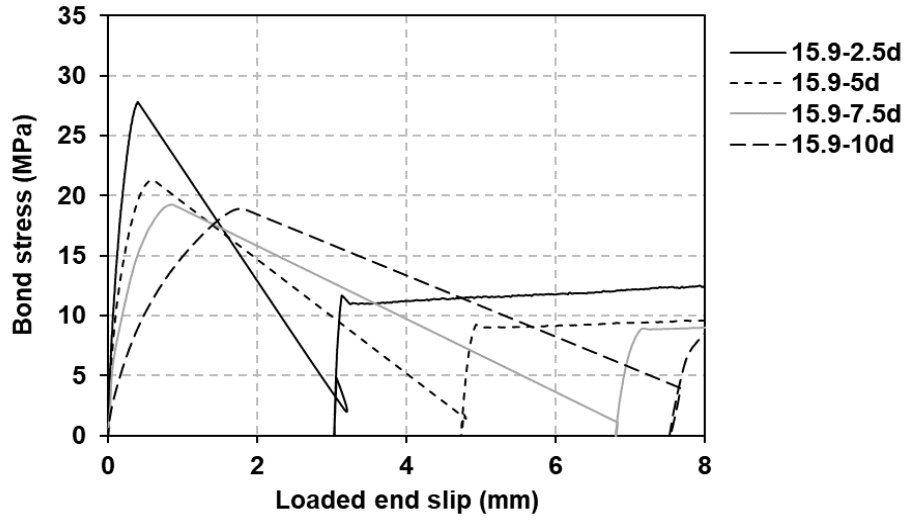

323

324

(a)

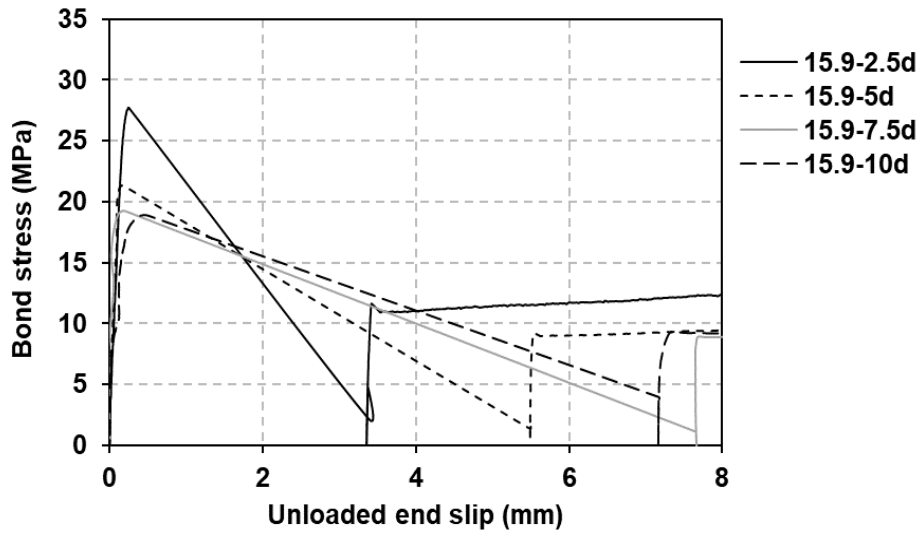

325

326

(b)

Figure 9. Bond stress - slip relationship for 15.9 mm GFRP (type B) reinforced cubes: (a) loaded and (b) unloaded end slips

327

328

329

330

331

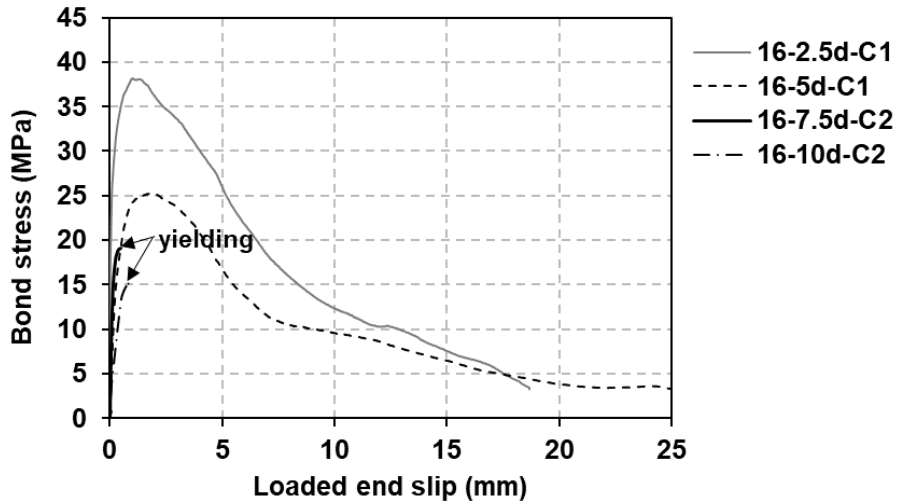

332

333

(a)

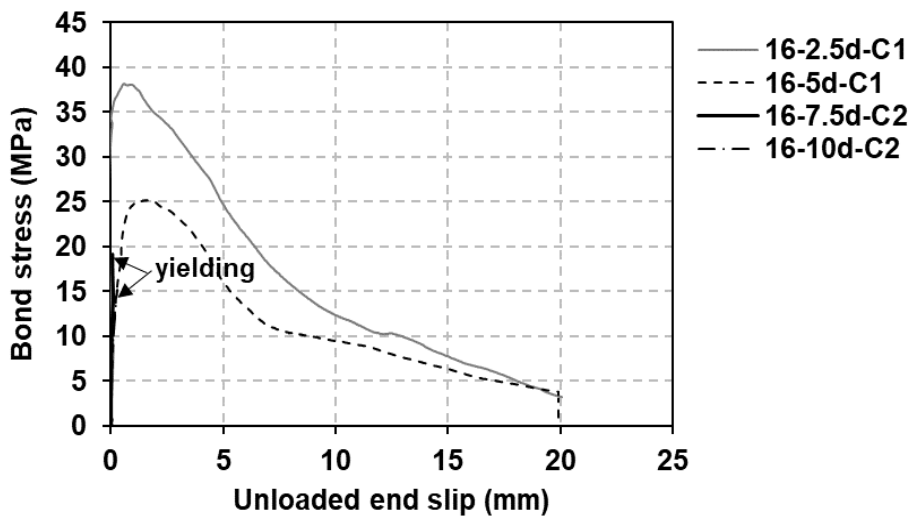

334

335

(b)

336 Figure 10. Bond stress - slip relationship for 16 mm steel reinforced cubes: (a) loaded and (b)
 337 unloaded end slips

338

339 3.2 Initial stiffness of bond stress – slip curves

340

341 Figure 11 (a and b) shows that the initial stiffness reduces with increasing the embedment

342 length as reported by Pepe et al. [31] and Achillides and Pilakoutas [1]. This might be

343 attributed to the non-uniform distribution of bond stresses along the bonded length. Also,

344 it is found that the initial stiffness of steel bars is higher than that of GFRP (HW-SC) bars

345 as shown in Figure 4.11 (a). This may be because of the differing surface properties and
 346 elastic modulus. This result was also confirmed by Baena et al. [5] from testing the pull-
 347 out cubes reinforced with different rebar types (glass FRP, carbon FRP and steel).

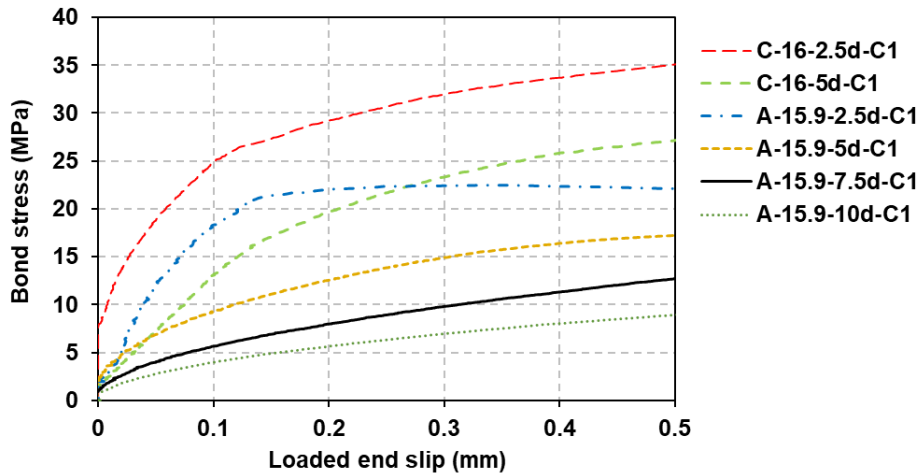

348

349

(a)

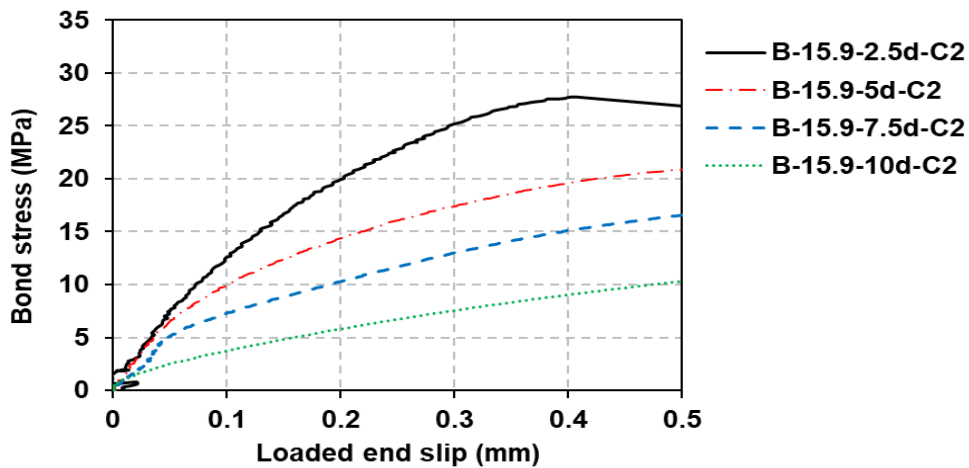

350

351

(b)

352 **Figure 11. Influence of elastic modulus and embedment length of bar on initial stiffness**

353

354 **3.3 Bond failure mechanism**

355 The failure mode observed for each pull-out test is listed in Tables 4 and 5. As anticipated,
 356 most specimens were failed by a pull-out mode as shown in Figure 12, because the cube

357 compressive strength of concrete was designed to be higher than 80 MPa to ensure the
358 occurrence of failure at the bar – concrete interface, rather than in the concrete. However,
359 the specimens reinforced with steel bars, having the embedment lengths of $7.5d_b$ and
360 $10d_b$, failed by bar fracture before attaining the bond strength as presented in Figure 14
361 (b). It can be concluded that the development length required to avoid bond failure
362 between the high-strength concrete and steel bars could be equal to or more than $7.5d_b$.
363 The specimens were split after testing to visually assess the bar and surrounding concrete
364 conditions. As for the specimens reinforced with GFRP (HW-SC) bars, some abrasions
365 were noted on the outer surface with stripping of sand coating as shown in Figure 13 (b).
366 White residue was seen on the trace of the whole embedment length, which indicated
367 crushing of the resin. As noted, the specimens with longer embedment lengths failed by
368 damage of the fibres as illustrated in Figure 13 (a). No apparent crushing of the
369 surrounding concrete was monitored in any of the GFRP reinforced specimens. The de-
370 bonding failure in the sand coated GFRP reinforced specimens occurred by the entire
371 detachment of the sand coated layer accompanied with a loud bang, when bond stress
372 reached the peak value as demonstrated in Figure 13 (c). The concrete also remained
373 uncrushed. This indicated that the bond strength between the outer layer and bar core
374 was lower than that between the high-strength concrete and sand coating. Therefore,
375 failure was controlled by the shear strength at the resin – bar core interface rather than
376 the shear strength between the bar and concrete. This mode of failure was expected in
377 the case of high-strength concrete. Similarity, Baena et al. [5] found that the sand coated
378 layer was totally stripped from the GFRP-SC rebar, when the compressive strength of
379 concrete was around 50 MPa. The specimens with a concrete strength of 30 MPa failed
380 by a pull-out mode due to damage in the concrete surface. Concerning steel reinforced

381 cubes failed by pull-out, Figure 14 (a) shows the remaining concrete still attached to the
382 outer surface of steel rebar. This is an indicator that bond failure occurred by shearing off
383 of the concrete between ribs.

384

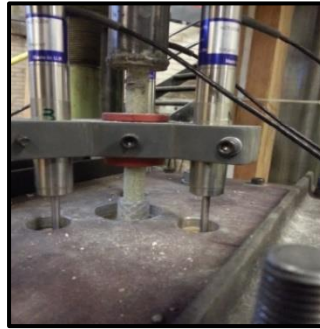

385
386 **Figure 12. Pull-out failure**

385

386

387



388
389 **(a) Cube (A-9.5-10d)**

388

389

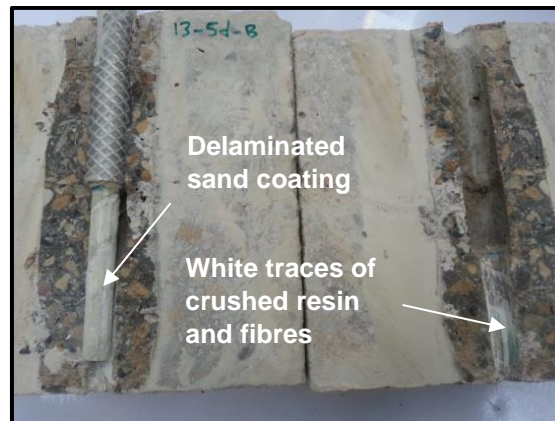

390 **(b) Cube (A-12.7-5d)**

390

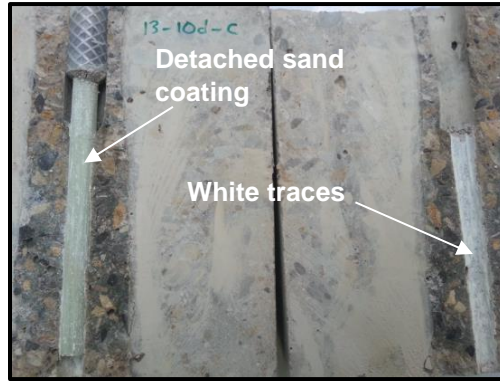

(c) Cube (B-12.7-10d)

Figure 13. Visual inspection for the specimens failed by pull-out



(a) Shear off concrete in cube (C-16-2.5d)



(b) Bar Fracture

Figure 14. Visual inspection of specimens reinforced with steel bars

3.4 Factors influencing bond strength

3.4.1 Effect of embedment length on bond strength

Generally, the trend of the test results points out that the longer the embedment length, the smaller the value of the average bond strength, irrespective of bar diameter in both GFRP types as well as steel bars. On the other hand, as expected, the failure load increases with increasing the embedment length. The relationships between the bond strength and embedment length are shown in Figures 15 and 16 for GFRP (type A) and GFRP (type B) reinforced cubes with different bar diameters, respectively. Based on the experimental results, it can be reported that the bond strength increases with reducing the bonded length and this observation was also confirmed by some previous authors [1, 2,

410 7, 13, 14]. This is attributed to two main factors: 1) non-linear distribution of bond stress
411 along the embedment length, and 2) the reduction in the bar size due to the Poisson's
412 ratio effect, leading to reductions in the frictional and mechanical interlock resistances
413 along the embedment length. In Figure 15, it is noted that no significant change occurred
414 in the bond strength with the increase of embedment length for smaller bar diameters. For
415 example, the bond strength of a 9.5 mm GFRP (HW-SC) bar having an embedment length
416 of $10 d_b$ is reduced by approximately 6% compared to that having an embedment length
417 of $2.5 d_b$. However, for larger bar diameters, the reduction rates in the bond strength of
418 $10 d_b$ specimens were 19% and 24% compared to $2.5d_b$ specimens, for 12.7 and 15.9
419 mm bar diameters, respectively. In Figure 16, the bond strength of $10 d_b$ specimens
420 having 9.5, 12.7 and 15.9 mm diameters is decreased by almost 34%, 36% and 32% in
421 comparison with $2.5 d_b$ specimens, respectively. In general, the reduction rate in bond
422 strength of GFRP (type B) is higher than the reduction rate in bond strength of GFRP (type
423 A). For comparison purposes, steel reinforced specimens also were tested to compare
424 their bond strength with those reinforced with GFRP re-bars. It was found that the bond
425 strength of GFRP (type A) bars was lower (50 to 65%) than that of steel bars, depending
426 on embedment length. This is because of different mechanical properties and surface
427 configurations. Regarding $7.5d_b$ and $10d_b$ steel reinforced cubes, the failure observed was
428 a bar rupture instead of a pull-out bar. Subsequently, these specimens did not compare
429 with counterparts reinforced with GFRP (type B) bars. It was noticed that the loaded end
430 slip increased with increasing the embedment length for the same bar diameter in both
431 GFRP types. The same observation was reported by Pepe et al. [31] from testing hinged
432 beams and Tekle et al. [14] from testing pullout specimens.

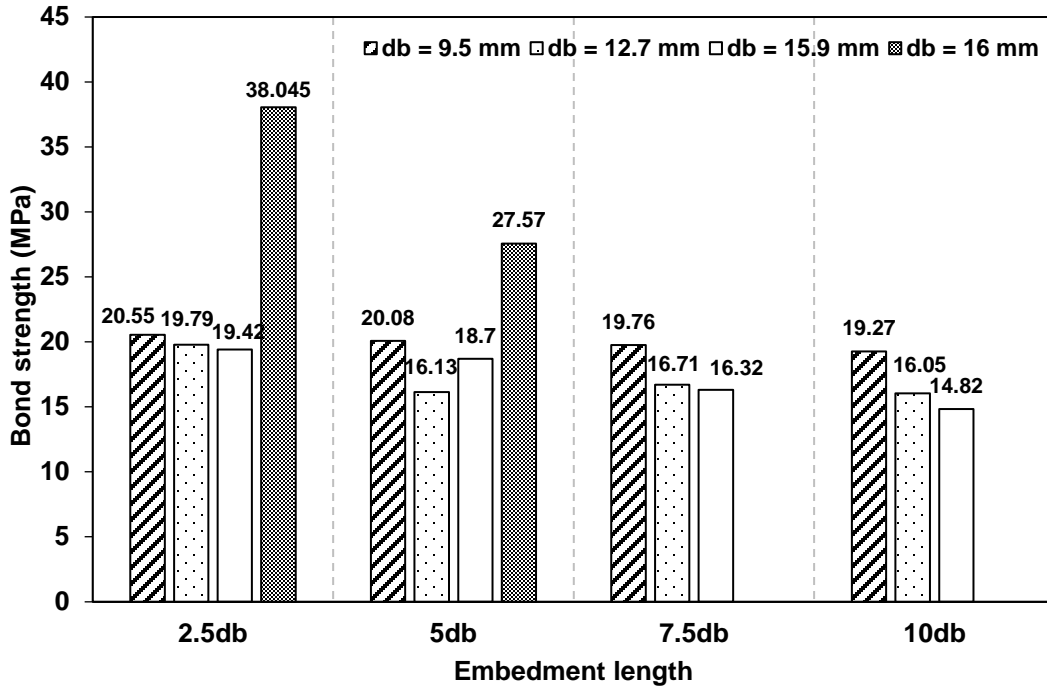

433
 434 Figure 15. Effect of the embedment length and bar diameter on the average bond strength of GFRP
 435 (HW-SC) bars embedded in HSC cubes
 436

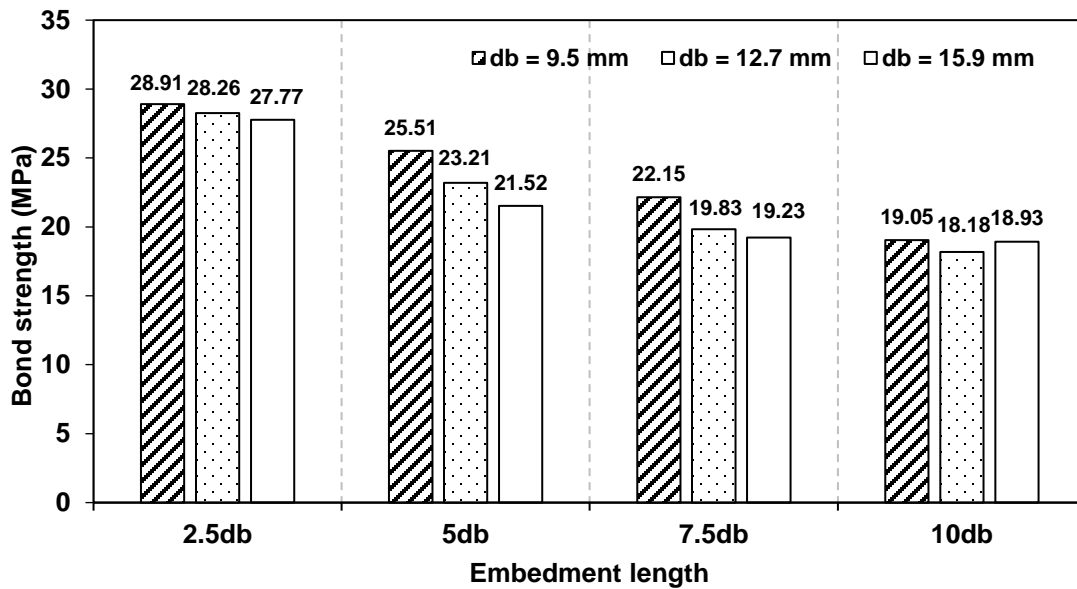

437
 438 Figure 16. Effect of the embedment length and bar diameter on the average bond strength of GFRP
 439 (SC) bars embedded in HSC cubes
 440
 441
 442
 443
 444

445 **3.4.2 Effect of the bar diameter on bond strength**

446 As shown in Figures 15 and 16, the average bond strength of GFRP bars reduces with
447 increasing the bar diameter similar to steel bars. This observation is valid for all test
448 specimens regardless of the embedment length. This trend was also reported by Nanni
449 et al. [32], Benmokrane et al. [33], Cosenza et al. [34], Tighiouart et al. [16], Achillides
450 [35], Achillides and Pilakoutas [1], Okelo and Yuan [2], Tepfers [36], Xue et al. [37], Baena
451 et al. [5], Hossain et al. [13], El Refai et al. [7] and Lee et al. [15]. This is attributed to the
452 nonlinear distribution of bond stresses along the embedment length [1, 5, 33], which is
453 more pronounced in larger bar diameters as longer embedment lengths are required. In
454 addition, Achillides and Pilakoutas [1] reported that the Poisson effect may have an effect
455 on this behaviour by reducing the bar diameter subjected to the pull-out load; this
456 reduction in bar diameter increases with the bar size. Subsequently, the frictional and
457 mechanical interlock stresses decrease along the embedment length. Shear lag was also
458 considered as a factor in explaining this phenomenon. The non-linear distribution of
459 normal stresses through the cross-section of the bar increases with increasing bar
460 diameter with normal stresses at bar surface higher than those closer to centre, violating
461 the average bond strength [1]. From Figure 15, GFRP (type A) bars with 9.5 mm diameters
462 showed bond strengths 5.5%, 6.9%, 17.4% and 23.1% higher than the bond strengths
463 developed by the 15.9 mm diameters for the embedment lengths of 2.5, 5, 7.5 and 10
464 times the bar diameter, respectively, with an average increase of 13.2%. It can be stated
465 that the decrease of bar diameter led to a slight increase in the bond strength for the
466 shorter embedment lengths. These percentages were 3.7%, 19.6%, 15.4% and 16.7%
467 more than the bond strengths developed by the 12.7 mm bar diameters for the same
468 embedment lengths, with an average increase of 13.8%. As can be seen in Figure 16,

469 GFRP (type B) bars with 12.7 mm bar diameters showed bond strengths that were 2.3%,
470 9%, 10.4% and 4.5% lower than those developed by 9.5 mm bar diameters for the
471 embedment lengths of 2.5, 5, 7.5 and 10 times the bar diameter, respectively, with an
472 average reduction of 6.5%. As for 15.9 mm diameters, these percentages were 4.1%,
473 18.5%, 15.2% and 0.6% less than those developed by 9.5 mm diameters for the same
474 embedment lengths, with an average reduction of 9.6%. For high-strength concrete pull-
475 out cubes, it was noticed that a reduction rate in bond strength reduced with increasing
476 the bar diameter for all embedment lengths. A similar observation was confirmed by Lee
477 et al. [15] and they also reported that the influence of bar diameter on bond strength was
478 affected by concrete compressive strength.

479 **3.4.3 Effect of bar surface treatment on bond strength**

480 Due to the important influence of the surface properties on bond behaviour, it is worth
481 comparing the bond performance of different surface treatments. From Figure 17, it can
482 be seen that the bond strength of GFRP (SC) bars is higher than that of GFRP (HW-SC)
483 bars due to their sand coated surface, which is similar to the results obtained from testing
484 pull-out specimens for cylinder compressive strengths of concrete in the range of 57 to 63
485 MPa [11]. The bond strength of GFRP (SC) bars strongly depends on friction resistance
486 provided by surface treatment, while little bearing resistance was provided by GFRP (HW-
487 SC) bars, unlike steel bars. However, according to the findings of Baena et al. [5], the
488 bond strength of GFRP (HW-SC) bars was higher than that of GFRP (SC) bars for a
489 concrete strength of 53 MPa, despite the fact that the GFRP bars used were similar to the
490 GFRP bars used in the current study. Moreover, Baena et al. [5] reported that the influence
491 of bar surface configurations on bond strength depended on concrete strength, where the

492 effect was less important in low - strength concrete compared to high - strength concrete.
 493 In addition, Lee et al. [12] found that bond strengths achieved by GFRP (HW-SC) re-bars
 494 were greater than those achieved by GFRP (SC) re-bars for different concrete strengths
 495 of 25, 40 and 70 MPa. As illustrated in Figure 17, the ratio of GFRP (type B) bond strength
 496 to GFRP (type A) bond strength varied from 0.99 to 1.44 with an average of 1.25,
 497 depending on bar diameter and embedment length. It was also noted that the
 498 corresponding loaded end slip in GFRP (SC) bars is smaller than that in GFRP (HW-SC)
 499 bars as shown in Tables 4 and 5. The same observation was reported by Lee et al. [12].

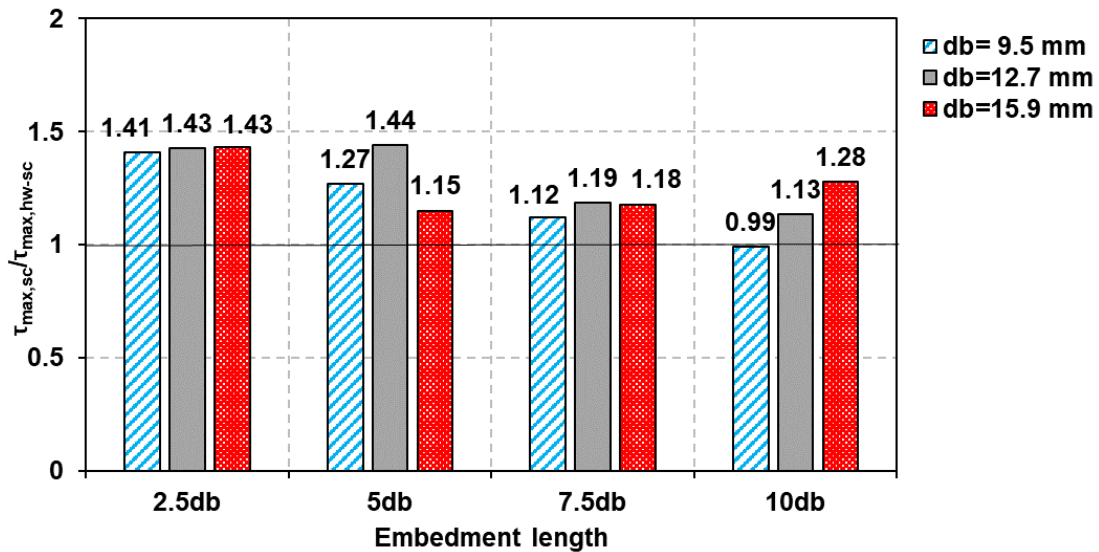

500

501 **Figure 17. Comparison between bond strength of GFRP (SC) bars and bond strength of GFRP**
 502 **(HW-SC) bars for HSC cubes**

503

504 **4 Comparison of test results with current codes**

505

506 For comparison purposes, the bond strengths provided by code equations were
 507 determined based on the geometrical and mechanical properties of the pull-out cubes.

508 The ACI-440.1R [21] code proposed an equation for GFRP bars based on the work
 509 conducted by Wambeke and Shield [38] as below:

510
$$\frac{\tau_{max}}{0.083\sqrt{f'_c}} = 4 + 0.3 \frac{c}{d_b} + 100 \frac{d_b}{l_e} \quad (4)$$

511 where τ_{max} is the bond strength (MPa), f'_c is the cylinder compressive strength of concrete
 512 (MPa) and c is the lesser of the cover to the centre of the bar or one-half of the centre-to-
 513 centre spacing of the bars being developed (mm). The ratio of c/d_b is limited to be less
 514 than 3.5. The CAN/CSA-S806 [22] and CAN/CSA-S6 [23] Canadian codes have also
 515 proposed the expressions for estimating the development length of FRP bars in
 516 conventional concrete in order to avoid bond failure. These equations were substituted in
 517 equation 1 to produce the expressions 5 and 6 for CAN/CSA-S806 and CAN/CSA-S6,
 518 respectively, which are used to calculate bond strength.
 519

520
$$\tau_{max} = \frac{d_{cs}\sqrt{f'_c}}{1.15k_1k_2k_3k_4k_5\pi d_b} \quad (5)$$

521
$$\tau_{max} = \frac{\left(d_{cs} + k_{tr} \frac{E_{frp}}{E_s}\right) f_{cr}}{0.45k_1k_6\pi d_b} \quad (6)$$

522 where:

523
$$k_{tr} = \frac{A_{tr}f_{yt}}{10.5sn} \quad \text{and} \quad \left(d_{cs} + k_{tr} \frac{E_{frp}}{E_s}\right) \leq 2.5d_b$$

524 where k_1 is a bar location factor (1.3 for horizontal reinforcement placed so that more than
 525 300 mm of fresh concrete is cast below the development length or splice, 1.0 for other
 526 cases), k_2 is a concrete density factor (1.3 for structural low-density concrete, 1.2 for
 527 structural semi-low-density concrete, 1.0 for normal density concrete), k_3 is a bar size
 528 factor (0.8 for $A_b \leq 300 \text{ mm}^2$, 1.0 for $A_b > 300 \text{ mm}^2$), A_b is the cross-sectional area of
 529 FRP bar (mm^2), k_4 is a bar fibre factor (1.0 for GFRP), k_5 is a bar surface factor (1.0 for
 530 surface-roughened or sand-coated surfaces and 1.05 for spiral pattern surface), k_6 is a
 531 bar surface factor, being the ratio of the bond strength of the FRP bar to that of a steel
 532 bar surface factor, being the ratio of the bond strength of the FRP bar to that of a steel
 533
 534

535 deformed bar with the same cross-sectional area as the FRP bar, but not greater than 1.0.
536 In the absence of experimental data, k_6 shall be taken as 0.8, d_{cs} is the smaller of the
537 cover to the centre of the bar or two-thirds of the centre-to-centre spacing of the bars
538 being developed (mm) (not greater than $2.5 d_b$), k_{tr} is a transverse reinforcement index,
539 A_{tr} is the cross-sectional area of transverse reinforcement (mm^2), s is the maximum
540 spacing centre to centre of the transverse bars within l_d (mm), f_{yt} is the yield stress in the
541 transverse reinforcement (MPa), n is the number of bars being developed along the
542 potential plane of bond splitting, f_{cr} is the cracking strength of concrete (MPa) ($0.4\sqrt{f'_c}$ for
543 normal-density concrete, $0.34\sqrt{f'_c}$ for semi-low-density concrete, $0.3\sqrt{f'_c}$ for low-density
544 concrete), E_{frp} and E_s are the modulus of elasticity of FRP and steel bars, respectively.
545 The square root of concrete strength should be less than 5 and 8 MPa for CSA-S806 and
546 CSA-S6, respectively.
547 The Japanese Design Code [24] suggested equation 7 to evaluate the bond strength of
548 FRP bars to concrete:

$$549 \quad \tau_{max} = \frac{f_{bod}}{\alpha_1} \quad (7)$$

550 where:

$$551 \quad f_{bod} = 0.28\alpha_2 f_c^{2/3} / 1.3 \leq 3.2 \text{ N/mm}^2$$

552 where f_{bod} is the design bond strength of concrete (MPa), α_2 is the modification factor
553 for the bond strength of CFRM (= 1 when the bond strength of CFRM is equal to or greater
554 than that of the deformed steel bars); otherwise α_2 shall be decreased according to the
555 test results, α_1 is a confinement modification factor (= 1 when $k_c \leq 1$; 0.9 when $1 < k_c \leq$
556 1.5; 0.8 when $1.5 < k_c \leq 2$; 0.7 when $2 < k_c \leq 2.5$ and 0.6 when $k_c > 2.5$), k_c is specified

557 as $\left(= \frac{c}{d_b} + \frac{15A_{tr}}{sd_b} + \frac{E_t}{E_s} \right)$, c is the smaller of the bottom clear cover of the main reinforcement
558 or half of the clear space between the reinforcement being developed (mm), A_{tr} is the
559 cross-sectional area of the transverse reinforcement (mm²), s is the maximum spacing
560 centre to centre of the transverse bars within l_{db} (mm), E_t is Young's modulus of elasticity
561 for the transverse reinforcement (MPa) and E_s is Young's modulus for steel (MPa).
562 Tables 6 and 7 summarize the comparative results of the experimental bond strengths of
563 various specimens with the predicted bond strengths calculated from the methods
564 provided in ACI 440.1R-15, CSA-S806-12, CSA-S6-14 and JSCE [24]. In Figure 18 (a to
565 c), the predictions provided by the ACI 440.1R, CSA-S806, CSA-S6 and JSCE equations
566 were plotted using the geometrical and mechanical properties of the pull-out cube in the
567 present study. It can be seen that the ACI 440.1R code overestimates the bond strength
568 of both GFRP bars having an embedment length of $2.5d_b$, while it is conservative for larger
569 embedment lengths. The average ratio of experimental to predicted bond strengths
570 obtained from the ACI 440.1R code is 1.06 with a COV of 34.3% and 1.45 with a COV of
571 25.6 for GFRP (type A) and GFRP (type B) reinforced cubes, respectively. CSA-S806,
572 CSA-S6 and JSCE codes are too conservative, where the average ratios of experimental
573 to predicted bond strengths for GFRP (type A) reinforced cubes are 4.41, 2.56 and 3.4
574 with a COV of 10.9%, respectively. They are 5.26, 3.21 and 4.26 with a COV of 17.4% for
575 GFRP (type B) reinforced cubes. Tables 6 and 7 show that the bond strength obtained
576 from Canadian and Japanese codes is not influenced by bar diameter and embedment
577 length because of the limitations of d_{cs} and k_c in the Canadian and Japanese codes,
578 respectively, as well as ignoring the effect of the embedment length on bond strength in
579 both codes. This conclusion was also confirmed by Hossain et al. [13], by comparing test

580 results with the Canadian code predictions. In contrast to the Canadian codes, the bond
581 strength reduces with increasing embedment length as per the ACI 440.1R code. No
582 change was noted in the ACI 440.1R predictions for identical specimens with the only one
583 variable being bar diameter, and this is due to the limitation of the ratio of c/d_b and the
584 value of the embedment length, that was taken as the ratio of the bar diameter, and this
585 led to cancel the effect of bar diameter represented by d_b/l_e . However, from Tables 6 and
586 7, there is a slight change in bond strength with the increase of bar diameter for the cubes
587 with the same embedment length, because of a small variation of concrete strength. The
588 ACI 440.1R code does not acknowledge the influence of surface properties on bond
589 strength. However, experimental results of GFRP (type A) and GFRP (type B) reinforced
590 specimens plotted in Figure 18 (a) revealed that bond strength of GFRP (type B) bars is
591 slightly higher than that of GFRP (type A) bars owing to the difference of surface
592 configuration. It was noticed that the tested results for helical wrapped with slightly sand
593 coated GFRP bars were closer to the ACI 440.1R predicted curve than the tested results
594 for sand coated GFRP (SC) bars. This may be attributed to the fact that the ACI 440.1R
595 equation was developed based on existing database containing limited surface types of
596 only two (spiral wrapping and helical lugs). The Japanese design code also neglects the
597 effect of surface configuration on bond strength. On the contrary, the Canadian codes
598 acknowledge the effect of bar surface on bond strength by suggesting a bar surface factor
599 of k_5 in the CSA-S806 equation and k_6 in the CSA-S6 equation. The ACI 440.1R equation
600 was developed based on concrete strength in the range of 28 to 45 MPa [38]. Therefore,
601 it cannot be assumed to be accurate for predicting the bond strength of GFRP bars in
602 HSC. The Canadian code limitations regarding concrete strength ($\sqrt{f'_c}$) should not be more

603 than 5 and 8 MPa for CSA-S806 and CSA-S6, respectively) and concrete cover (d_{cs} is not
604 greater than $2.5d_b$) lead to a constant value of the predicted bond strength for all
605 specimens as illustrated in Figure 18 (b). The modification factor, α_2 , in the Japanese
606 equation was taken as 1. According to the Japanese code limitation regarding the design
607 bond strength of concrete, the predicted bond strength is constant when the concrete
608 strength exceeds 57 MPa as shown in Figure 18 (c). Because of the absence of
609 transverse reinforcement in the pull-out cubes, the effect of confinement considered by
610 the transverse reinforcement index, k_{tr} , in the CSA S6 equation and the transverse
611 reinforcement in the JSCE equation was neglected. The minimum value of the bond
612 strength in experimental results is higher than the bond strengths obtained from Canadian
613 and Japanese design codes, thus, the development length provided by these codes will
614 be over satisfactory.

615 **Table 6. Comparison of test results of GFRP (type A) reinforced cubes with different code's**
616 **predictions**

Specimen label	τ_{exp} (MPa)	ACI 440.1R τ_{pred} (MPa)	$\frac{\tau_{exp}}{\tau_{pred}}$	CSA-S806 τ_{pred} (MPa)	$\frac{\tau_{exp}}{\tau_{pred}}$	CSA-S6 τ_{pred} (MPa)	$\frac{\tau_{exp}}{\tau_{pred}}$	JSCE 1997 τ_{pred} (MPa)	$\frac{\tau_{exp}}{\tau_{pred}}$
A-9.5-2.5d	20.55	34	0.60	4.11	5	7.07	2.91	5.33	3.85
A-9.5-5d	20.08	18.91	1.06	4.11	4.89	7.07	2.84	5.33	3.77
A-9.5-7.5d	19.76	13.88	1.42	4.11	4.81	7.07	2.79	5.33	3.71
A-9.5-10d	19.27	11.36	1.70	4.11	4.69	7.07	2.73	5.33	3.61
A-12.7-2.5d	19.79	34.07	0.58	4.11	4.82	7.07	2.80	5.33	3.71
A-12.7-5d	16.13	18.95	0.85	4.11	3.92	7.07	2.28	5.33	3.02
A-12.7-7.5d	16.71	13.90	1.20	4.11	4.07	7.07	2.36	5.33	3.13
A-12.7-10d	16.05	11.38	1.41	4.11	3.91	7.07	2.27	5.33	3.01
A-15.9-2.5d	19.42	34.76	0.56	4.11	4.73	7.07	2.75	5.33	3.64
A-15.9-5d	18.70	19.33	0.97	4.11	4.55	7.07	2.64	5.33	3.51
A-15.9-7.5d	16.32	14.23	1.15	4.11	3.97	7.07	2.31	5.33	3.06
A-15.9-10d	14.82	11.65	1.27	4.11	3.61	7.07	2.10	5.33	2.78
Average			1.06		4.41		2.56		3.40
COV %			34.3		10.9		10.9		10.9

617 Note: τ_{exp} is the experimental bond strength; τ_{pred} is the predicted bond strength and COV is a Coefficient
 618 of variation.

619
 620
 621
 622

Table 7. Comparison of test results of GFRP (type B) reinforced cubes with different code's predictions

Specimen label	τ_{exp} (MPa)	ACI 440.1R τ_{pred} (MPa)	$\frac{\tau_{exp}}{\tau_{pred}}$	CSA-S806 τ_{pred} (MPa)	$\frac{\tau_{exp}}{\tau_{pred}}$	CSA-S6 τ_{pred} (MPa)	$\frac{\tau_{exp}}{\tau_{pred}}$	JSCE 1997 τ_{pred} (MPa)	$\frac{\tau_{exp}}{\tau_{pred}}$
B-9.5-2.5d	28.91	31.42	0.92	4.32	6.69	7.07	4.09	5.33	5.42
B-9.5-5d	25.51	16.89	1.51	4.32	5.91	7.07	3.61	5.33	4.78
B-9.5-7.5d	22.15	12.40	1.79	4.32	5.13	7.07	3.13	5.33	4.15
B-9.5-10d	19.05	10.15	1.88	4.32	4.41	7.07	2.69	5.33	3.57
B-12.7-2.5d	28.26	30.78	0.92	4.32	6.54	7.07	4.00	5.33	5.30
B-12.7-5d	23.21	17.12	1.36	4.32	5.37	7.07	3.28	5.33	4.35
B-12.7-7.5d	19.83	12.38	1.60	4.32	4.59	7.07	2.80	5.33	3.72
B-12.7-10d	18.18	10.14	1.79	4.32	4.21	7.07	2.57	5.33	3.41
B-15.9-2.5d	27.77	30.34	0.92	4.32	6.43	7.07	3.93	5.33	5.21
B-15.9-5d	21.52	16.87	1.28	4.32	4.98	7.07	3.04	5.33	4.04
B-15.9-7.5d	19.23	12.38	1.55	4.32	4.45	7.07	2.72	5.33	3.61
B-15.9-10d	18.93	10.14	1.87	4.32	4.38	7.07	2.68	5.33	3.55
Average			1.45		5.26		3.21		4.26
COV %			25.6		17.4		17.4		17.4

623 Note: τ_{exp} is the experimental bond strength; τ_{pred} is the predicted bond strength and COV is a Coefficient
 624 of variation.

625
 626
 627

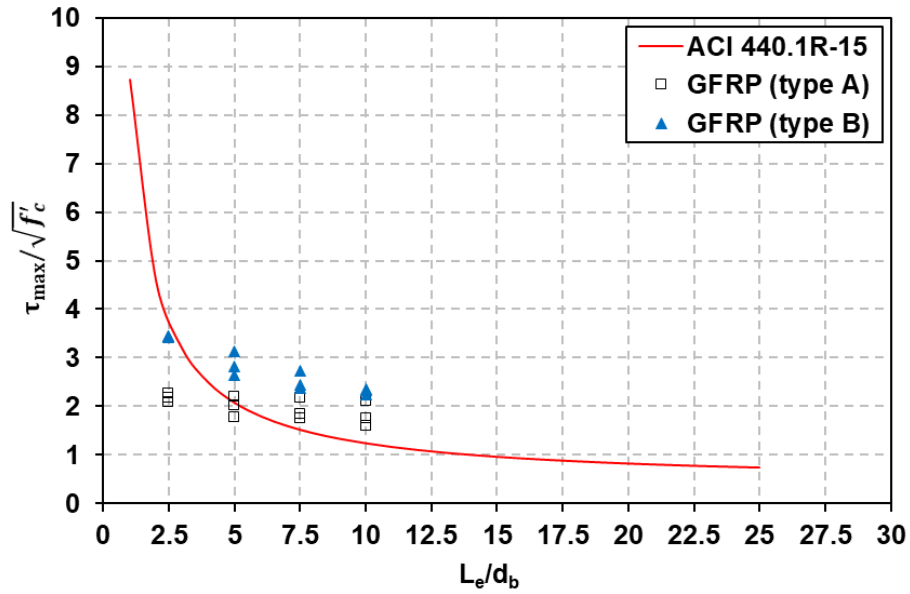

(a) Variation of normalized bond strength with embedment length

628
629
630
631

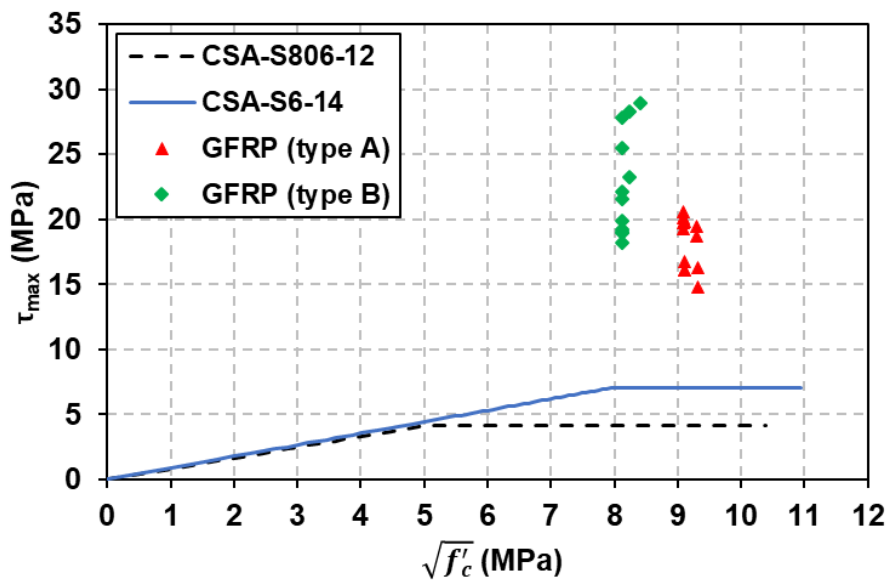

(b) Variation of bond strength vs. $\sqrt{f'_c}$

632
633
634
635
636
637
638
639
640
641

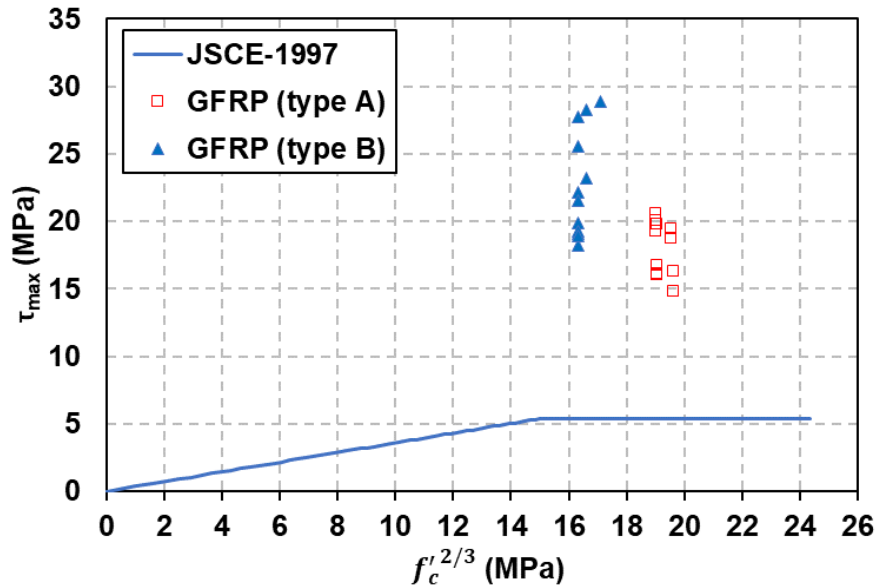

(c) Variation of bond strength vs. $f_c^{1/3}$

Figure 18. Comparison between experimental and different design code predicted bond strengths for cubes

5 Conclusions

Test results of 84 HSC pull-out specimens reinforced with GFRP and steel bars have been presented and discussed in this paper. The parameters investigated were diameter, embedment length and surface configuration of the reinforcing bars. The following conclusions are drawn:

- The majority of specimens failed by a pull-out mode. The bond failure of GFRP (HW-SC) reinforced specimens occurred within the interfaces of the resin-rich layer and fibres, while it occurred within the interfaces between the sand coated layer and the bar core in GFRP (SC) reinforced specimens. The shearing off of concrete between the steel ribs was responsible for a pull-out failure in control specimens.
- GFRP (HW-SC) bars showed interfacial bond behaviour differing from that of GFRP (SC) bars. A helically wrapped with slightly sand coated surface produced a

661 more ductile post peak response with high residual stresses owing to high friction
662 forces between remaining undulations and concrete, similar to previous
663 observations in the literature for normal-strength concrete. A sand coated surface
664 produced a brittle failure because of the complete stripping of sand grains from the
665 bar core, unlike the literature (a smoother softening curve in the case of normal
666 strength concrete).

- 667 • Overall, the bond strength of both GFRP types increased with reducing the
668 embedment length and bar diameter.
- 669 • In general, the reduction rate of bond strength of both GFRP types with increasing
670 the bar diameter and the embedment length was reduced in the case of high-
671 strength concrete.
- 672 • The sand coated surface offered a bond strength higher than that offered by the
673 helically wrapped with slightly sand coated surface for a given concrete strength,
674 but the corresponding slip for GFRP (SC) bars was less than that for GFRP (HW-
675 SC) bars.
- 676 • In general, all design codes provided conservative predictions, but ACI predictions
677 were unconservative for pull-out cubes having an embedment length of $2.5d_b$. ACI
678 predictions showed a good agreement with experimental bond strengths compared
679 to other codes.
- 680 • Both Canadian and Japanese codes are overly safe. Therefore, modifications to
681 these codes are necessary for a more accurate prediction of bond strength of
682 GFRP bars embedded in HSC.

683

684 **Acknowledgement**

685 The first Author would like to acknowledge to the financial support of Higher Education of
686 Libya (293/2013). The authors are also gratefully to PULTRALL & V.ROD for providing
687 the GFRP (SC) bars, and Hughes brother's manufacturer and Fortius, Belgium Vendor for
688 providing the ASLAN 100 GFRP (HW-SC) bars.

689

690

691

692

693

694

695

696

697

698

699

700

701

702

703

704 **References**

- 705 1. Achillides, Z. and K. Pilakoutas, Bond behaviour of fibre reinforced polymer bars
706 under direct pullout conditions. Journal of Composites for Construction, 2004. 8(2):
707 p. 173-181.
- 708 2. Okelo, R. and R.L. Yuan, Bond strength of fibre reinforced polymer rebars in normal
709 strength concrete. Journal of composites for construction, 2005. 9(3): p. 203-213.
- 710 3. Tastani, S. and S. Pantazopoulou, Bond of GFRP bars in concrete: experimental
711 study and analytical interpretation. Journal of Composites for Construction, 2006.
712 10(5): p. 381-391.
- 713 4. Hao, Q.-d., Y.-l. Wang, Z.-c. Zhang, and J.-p. Ou, Bond strength improvement of
714 GFRP rebars with different rib geometries. Journal of Zhejiang University
715 SCIENCE A, 2007. 8(9): p. 1356-1365.
- 716 5. Baena, M., L. Torres, A. Turon, and C. Barris, Experimental study of bond
717 behaviour between concrete and FRP bars using a pull-out test. Composites Part
718 B: Engineering, 2009. 40(8): p. 784-797.
- 719 6. Hao, Q., Y. Wang, Z. He, and J. Ou, Bond strength of glass fibre reinforced polymer
720 ribbed rebars in normal strength concrete. Construction and Building materials,
721 2009. 23(2): p. 865-871.
- 722 7. El Refai, A., M.-A. Ammar, and R. Masmoudi, Bond performance of basalt fibre-
723 reinforced polymer bars to concrete. Journal of Composites for Construction, 2014.
724 19(3): p. 04014050.
- 725 8. Xue, W., Q. Zheng, Y. Yang, and Z. Fang, Bond behaviour of sand-coated
726 deformed glass fibre reinforced polymer rebars. Journal of Reinforced Plastics and
727 Composites, 2014. 33(10): p. 895-910.
- 728 9. Benmokrane, B., O. Chaallal, and R. Masmoudi, Glass fibre reinforced plastic
729 (GFRP) rebars for concrete structures. Construction and Building Materials, 1995.
730 9(6): p. 353-364.
- 731 10. Lee, J.-Y., T.-Y. Kim, T.-J. Kim, C.-K. Yi, J.-S. Park, Y.-C. You, and Y.-H. Park,
732 Interfacial bond strength of glass fibre reinforced polymer bars in high-strength
733 concrete. Composites Part B: Engineering, 2008. 39(2): p. 258-270.
- 734 11. Davalos, J.F., Y. Chen, and I. Ray, Effect of FRP bar degradation on interface bond
735 with high strength concrete. Cement and Concrete Composites, 2008. 30(8): p.
736 722-730.
- 737 12. Lee, J.Y., C.K. Yi, Y.G. Cheong, and B.I. Kim, Bond stress–slip behaviour of two
738 common GFRP rebar types with pullout failure. Magazine of Concrete Research,
739 2012. 64(7): p. 575-591.
- 740 13. Hossain, K.M.A., D. Ametrano, and M. Lachemi, Bond Strength of Standard and
741 High-Modulus GFRP Bars in High-Strength Concrete. Journal of Materials in Civil
742 Engineering, 2014. 26(3): p. 449-456.

- 743 14. Tekle, B.H., A. Khennane, and O. Kayali, Bond Properties of Sand-Coated GFRP
744 Bars with Fly Ash–Based Geopolymer Concrete. *Journal of Composites for*
745 *Construction*, 2016. 20(5): p. 1-13.
- 746 15. Lee, J.-Y., A.-R. Lim, J. Kim, and J. Kim, Bond behaviour of GFRP bars in high-
747 strength concrete: bar diameter effect. *Magazine of Concrete Research*, 2017.
748 69(11): p. 541-554.
- 749 16. Tighiouart, B., B. Benmokrane, and D. Gao, Investigation of bond in concrete
750 member with fibre reinforced polymer (FRP) bars. *Construction and Building*
751 *Materials*, 1998. 12(8): p. 453-462.
- 752 17. Chaallal, O. and B. Benmokrane, Pullout and bond of glass-fibre rods embedded
753 in concrete and cement grout. *Materials and structures*, 1993. 26(3): p. 167-175.
- 754 18. Veljkovic, A., V. Carvelli, M.M. Haffke, and M. Pahn, Concrete cover effect on the
755 bond of GFRP bar and concrete under static loading. *Composites Part B:*
756 *Engineering*, 2017. 124: p. 40-53.
- 757 19. Harajli, M. and M. Abouniaj, Bond performance of GFRP bars in tension:
758 Experimental evaluation and assessment of ACI 440 guidelines. *Journal of*
759 *Composites for Construction*, 2010. 14(6): p. 659-668.
- 760 20. Esfahani, M.R., M. Rakhshanimehr, and S.R. Mousavi, Bond Strength of Lap-
761 Spliced GFRP Bars in Concrete Beams. *Journal of Composites for Construction*,
762 2013. 17(3): p. 314-323.
- 763 21. ACI-440.1R, Guide for the design and construction of concrete reinforced with FRP
764 bars. 2015, ACI Committee 440: Farmington Hills, M1.
- 765 22. CAN/CSA-S806, Design and construction of building structures with fibre-
766 reinforced polymers. 2012, Canadian Standards Association: Mississauga,
767 Ontario, Canada.
- 768 23. CAN/CSA-S6, Canadian Highway Bridge Design Code. 2014, Canadian Standard
769 Association.
- 770 24. JSCE, Recommendation for Design and Construction of Concrete Structures using
771 Continuous Fibre Reinforcing Materials. 1997, Research Committee Fibre-
772 Reinforcing Materials: Tokyo, Japan.
- 773 25. ACI-440.3R, Guide Test Methods for Fibre-Reinforced Polymers (FRPs) for
774 Reinforcing or Strengthening Concrete Structures. 2012, ACI Committee 440:
775 Farmington Hills, M1.
- 776 26. ASTM-D7205/D7205M-06, Standard test method for tensile properties of fibre
777 reinforced polymer matrix composite bars. 2006, ASTM International: West
778 Conshohocken, United States. p. 13.
- 779 27. ASTM-A706/A706M-09b, Standard Specification for Low-Alloy Steel Deformed
780 and Plain Bars for Concrete Reinforcement. 2009, ASTM International: West
781 Conshohocken, United States. p. 6.

- 782 28. Vint, L. and S. Sheikh, Investigation of Bond Properties of Alternate Anchorage
783 Schemes for Glass Fibre-Reinforced Polymer Bars. ACI Structural Journal, 2015.
784 112(1): p. 59.
- 785 29. Antonietta Aiello, M., M. Leone, and M. Pecce, Bond performances of FRP rebars-
786 reinforced concrete. Journal of materials in civil engineering, 2007. 19(3): p. 205-
787 213.
- 788 30. Arias, J.P.M., A. Vazquez, and M.M. Escobar, Use of sand coating to improve
789 bonding between GFRP bars and concrete. Journal of composite materials, 2012.
790 46(18): p. 2271-2278.
- 791 31. Pepe, M., H. Mazaheripour, J. Barros, J. Sena-Cruz, and E. Martinelli, Numerical
792 calibration of bond law for GFRP bars embedded in steel fibre-reinforced self-
793 compacting concrete. Composites Part B: Engineering, 2013. 50: p. 403-412.
- 794 32. Nanni, A., M. Al-Zaharani, S. Al-Dulaijan, C. Bakis, and I. Boothby. bond of FRP
795 reinforcement to concrete-experimental results. in Non-Metallic (FRP)
796 Reinforcement for Concrete Structures: Proceedings of the Second International
797 RILEM Symposium. 1995. CRC Press.
- 798 33. Benmokrane, B., B. Tighiouart, and O. Chaallal, Bond strength and load distribution
799 of composite GFRP reinforcing bars in concrete. ACI Materials Journal, 1996.
800 93(3): p. 246-252.
- 801 34. Cosenza, E., G. Manfredi, and R. Realfonzo, Behaviour and modeling of bond of
802 FRP rebars to concrete. Journal of composites for construction, 1997. 1(2): p. 40-
803 51.
- 804 35. Achillides, Z., Bond behaviour of FRP bars in concrete, in Dept. of Civil and
805 Structural Engineering. 1998, University of Sheffield: Sheffield, U.K.
- 806 36. Tepfers, R., Bond clause proposals for FRP bars/rods in concrete based on
807 CEB/FIP Model Code 90. Part 1: Design bond stress for FRP reinforcing bars.
808 Structural concrete, 2006. 7(2): p. 47-55.
- 809 37. Xue, W., X. Wang, and S. Zhang, Bond properties of high-strength carbon fibre-
810 reinforced polymer strands. ACI Materials Journal, 2008. 105(1): p. 11-19.
- 811 38. Wambeke, B.W. and C.K. Shield, Development length of glass fibre-reinforced
812 polymer bars in concrete. ACI Structural Journal, 2006. 103(1): p. 11-17.

813

814 **Abbreviations**

815	GFRP	Glass Fibre Reinforced Polymers
816	HW-SC	Helical Wrapping with slightly Sand Coating
817	SC	Sand Coating
818	CFRM	Continuous Fibre Reinforcing Materials
819	NSC	Normal Strength Concrete
820	HSC	High Strength Concrete

821	ACI	American Concrete Institute
822	ASTM	American Society for Testing and Materials
823	JSCE	Japanese Society of Civil Engineers
824	CSA	Canadian Standards Association
825	COV	Coefficient of Variation
826	LVDT	Linear Variable Displacement Transducer
827	PO	Pull-out
828	SP	Splitting
829	Y	Yielding

830

831 **Notations**

832	d_b	Bar diameter
833	L_e	Embedment length
834	L_{db}	Development length
835	L_a	Length from the LVDTs support point to the top surface of the bonded bar
836	A_b	Cross sectional area of bar
837	A_t	Cross-sectional area of transverse reinforcement
838	f'_c	Cylinder compressive strength of concrete
839	f_{cu}	Cube compressive strength of concrete
840	f_t	Tensile strength of concrete
841	f_{cr}	Cracking strength of concrete
842	E_{frp}	Elastic modulus of FRP rebar
843	E_s	Elastic modulus of steel rebar
844	α_1	Confinement modification factor
845	α_2	Modification factor for bond strength
846	f_{bod}	Design bond strength of concrete
847	E_t	Young's modulus of elasticity for the transverse reinforcement
848	f_{yt}	Yield stress in transverse reinforcement
849	k_1	Top bar modification factor
850	k_2	Concrete density factor
851	k_3	Bar size factor
852	k_4	Bar fibre factor
853	k_5	Surface profile factor
854	k_6	Bar surface factor
855	k_{tr}	Transverse reinforcement index
856	C	The lesser of the concrete cover to the centre of the bar or one-half of the centre-to-centre spacing of the bars being developed
857		
858	d_{cs}	The smaller of the distance from the closest concrete surface to the centre of the bar or two-thirds of the centre to centre spacing of the bars
859		

860	s	Maximum spacing centre to centre of transverse bars within l_{db}
861	n	Number of bars being developed along the potential plane of bond splitting
862	τ_{max}	Peak bond stress
863	τ	Bond stress
864	τ_{avg}	Average bond strength
865	τ_{pred}	Predicted bond strength
866	τ_{exp}	Experimental bond strength
867	F	Applied tensile load
868	F_{max}	Failure load
869	s_{le}	Loaded end slip at the peak bond stress
870	s_{ul}	Unloaded end slip at the peak bond stress
871	s_e	Elongation of the bar
872	s_{total}	LVDT measurement at the loaded end
873	$s_{le,m}$	Average loaded end slip at the peak bond stress
874	$s_{ul,m}$	Average unloaded end slip at the peak bond stress